



View this document in HTML
crestron.com/docs/7236



Product Manual

C2N-IO

Control Port Expansion Module

Have feedback on this document? Contact docfeedback@crestron.com.

The original language version of this document is U.S. English.
All other languages are a translation of the original document.

Regulatory Model: C2N-IO

Crestron product development software is licensed to Crestron dealers and Crestron Service Providers (CSPs) under a limited nonexclusive, nontransferable Software Development Tools License Agreement. Crestron product operating system software is licensed to Crestron dealers, CSPs, and end-users under a separate End-User License Agreement. Both of these Agreements can be found on the Crestron website at www.crestron.com/legal/software_license_agreement.

The product warranty can be found at www.crestron.com/warranty.

The specific patents that cover Crestron products are listed online at www.crestron.com/legal/patents.

Certain Crestron products contain open source software. For specific information, please visit www.crestron.com/opensource.

Crestron, the Crestron logo, 3-Series, 4-Series, and Cresnet are either trademarks or registered trademarks of Crestron Electronics, Inc. in the United States and/or other countries. 3M and Dual Lock are either trademarks or registered trademarks of 3M Company in the United States and/or other countries. Intertek is either a trademark or registered trademark of Intertek Group in the United States and/or other countries. UL is either a trademark or registered trademark of Underwriters Laboratories, Inc. in the United States and/or other countries. Other trademarks, registered trademarks, and trade names may be used in this document to refer to either the entities claiming the marks and names or their products. Crestron disclaims any proprietary interest in the marks and names of others. Crestron is not responsible for errors in typography or photography.

©2026 Crestron Electronics, Inc.

Contents

- C2N-IO** **4**
 - Features 5
 - Physical Description 6
 - Front 6

- Specifications** **7**
 - Product Specifications 7
 - Dimension Drawings 8

- Installation** **9**
 - In the Box 9
 - Mounting 9
 - Hardware Hookup 10
 - Connect with Zūm 10

- Configuration** **12**
 - DIP Switches on GLS-SIM 12
 - Sensor Digital Input 12
 - Analog Input 14

- Resources** **17**
 - Crestron Support and Training 17
 - Programmer and Developer Resources 17
 - Product Certificates 17
 - Related Documentation 17

C2N-IO

The [C2N-IO](#) is a compact device that adds control ports to any Crestron 2-Series 3-Series®, or 4-Series® control system. It connects via the Cresnet® control network and provides one RS-232, one IR, and two relay control ports. It can be mounted to any flat surface using two screws or adhesive reclosable fastener (3M® Dual Lock® included).

NOTE: The RS-232 COM port is intended for use with relatively simple devices that send and receive small packets and do not generate a lot of data. A small amount of delay may be normal when sending or receiving some control commands on a low-speed serial network. Cresnet networks with many devices tend to exhibit more delay.

This section provides the following information:

- [Features](#)
- [Physical Description](#)

Features

Key features include:

- Fits within a two-gang wall box
- Provides one RS-232, 1 IR/serial, and two relay ports¹
- Compatible with any Crestron 2-Series, 3-Series®, or 4-Series® control system
- Interfaces via the Cresnet® control bus
- 24VDC Cresnet powered
- Surface mount bracket included

Physical Description

The C2N-IO provides the following connectors, controls, and indicators.

Front

The following illustration shows the front of the C2N-IO.

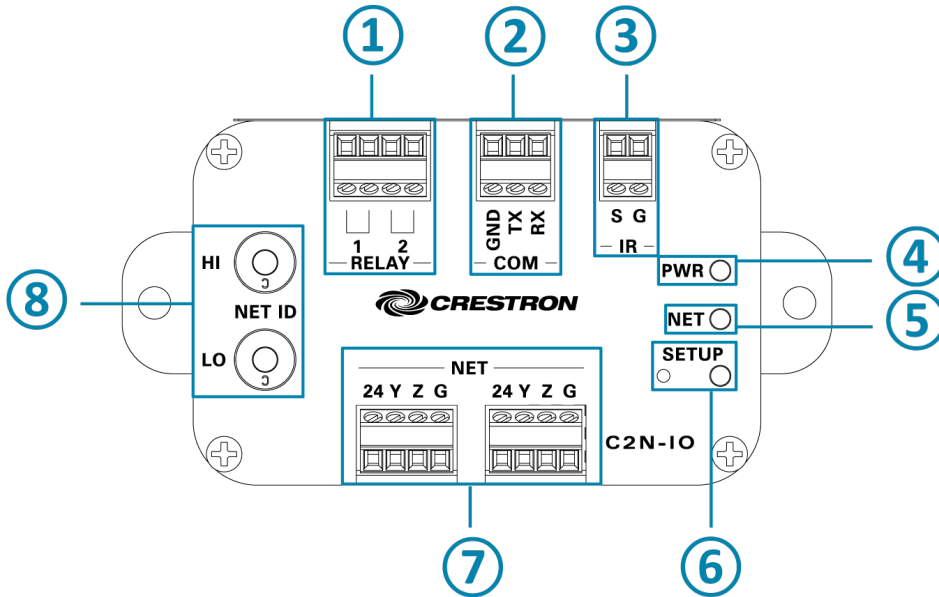

- ① **Relay 1-2:** (1) 4-pin captive screw terminal block comprising two normally open, isolated relays; Rated 1A, 30 VAC/VDC; Solid-state arc suppression across contacts
- ② **COM:** (1) 3-pin captive screw terminal block, bidirectional RS-232 port 1; Up to 115.2k baud; Software handshaking support
- ③ **IR:** (1) 2-pin captive screw terminal block, IR/Serial output port; IR output up to 1.2 MHz; 1-way serial TTL/RS-232 (0-5 VDC) up to 115.2k baud
- ④ **NET:** (2) 4-pin captive screw terminal blocks, paralleled
Cresnet client port, connects to Cresnet control network
- ⑤ **PWR:**(1) Green LED, indicates 24 VDC operating power supplied via Cresnet control network
- ⑥ **NET:** (1) Amber LED, indicates communication with Cresnet system
- ⑦ **SETUP:** (1) Red LED and (1) recessed miniature pushbutton for TSID
- ⑧ **NET ID:** (2) Rotary switches for manually setting Cresnet ID; '00' setting enables touch-settable ID (TSID)

Specifications

Product specifications for the C2N-IO.

Product Specifications

Communications

Cresnet® Network	Cresnet client mode, 2-Series, 3-Series®, or 4-Series® control system compatible
RS-232	Supports 2-way device control and monitoring up to 115.2k baud with software handshaking ¹
IR/Serial	Supports 1-way device control via infrared up to 1.2 MHz or serial TTL/RS-232 (0-5VDC) up to 115.2k baud

Connectors

RELAY 1 – 2	(1) 4-pin captive screw terminal block comprising (2) normally open, isolated relays; Rated 1A, 30 VAC/VDC; Solid-state arc suppression across contacts
COM	(1) 3-pin captive screw terminal block, bidirectional RS-232 port 1; Up to 115.2k baud; software handshaking support
IR	(1) 2-pin captive screw terminal block, IR/Serial output port; IR output up to 1.2 MHz; 1-way serial TTL/RS-232 (0-5VDC) up to 115.2k baud
NET	(2) 4-pin captive screw terminal blocks, paralleled Cresnet client port, connects to Cresnet control network

Controls and Indicators

NET ID	(2) Rotary switches for manually setting Cresnet ID; '00' setting enables touch-settable ID (TSID)
PWR	(1) Green LED, indicates 24VDC operating power supplied via Cresnet control network
NET	(1) Amber LED, indicates communication with Cresnet system
SETUP	(1) Red LED and (1) recessed miniature pushbutton for TSID

Power Requirements

Cresnet Power Usage	2.5 W (105 mA @ 24VDC)
----------------------------	------------------------

Environmental

Temperature	32° to 104°F (0° to 40°C)
Humidity	10% to 90% RH (noncondensing)
Heat Dissipation	3.5 BTU/hr

Construction

Metal, freestanding or surface mount, surface mount bracket and 3M® Dual Lock® reclosable fastener included, fits inside a 2-gang electrical box or 2-gang UK (BS 4662) electrical box

Dimensions

Height	2.25 in. (58 mm)
Width	3.50 in. (89 mm), 4.38 in. (112 mm) with bracket
Depth	0.83 in. (21 mm)

Weight

2.7 oz (75 g)

Compliance

Regulatory Model: C2N-IO

FCC Part 15 Class B, IC Class B, CE, Intertek® Listed for US and Canada

Note:

Dimension Drawings

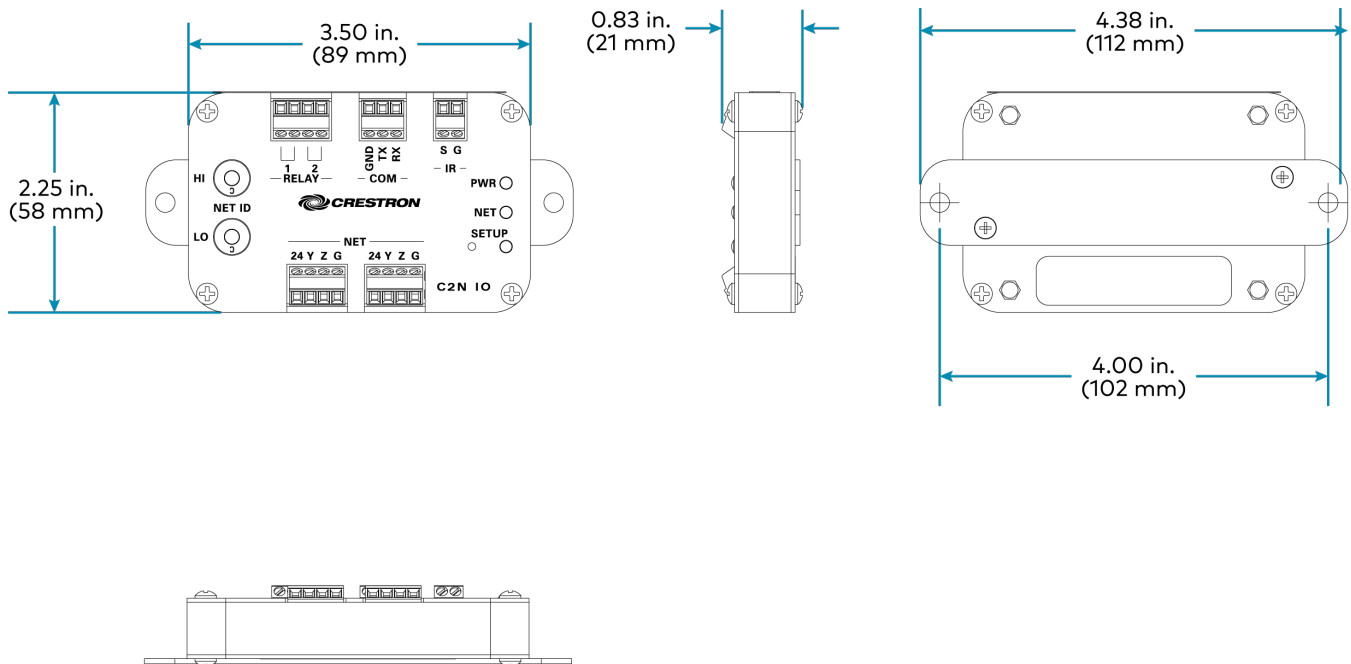

Installation

The C2N-IO can be mounted inside a standard 2-gang U.S. or U.K. electrical box using the included 3M Dual Lock fastener or mounted to another suitable location using the included mounting bracket.

To use the included mounting bracket, use the included 04-40 x 1/8" screws to attach the mounting bracket as shown in the following illustration. The only tool required is a #1 Phillips screwdriver.

In the Box

Qty.	Description
1	C2N-IO, Control Port Expansion Module
Additional Items	
1	Bracket, Metal Plate (2030826)
2	Screws, 4-40 x 1/4 in., Undercut Head, Phillips (2023106)
1	3M® Dual Lock® Fastener, 0.75 in. x 0.75 in., Clear, Adhesive (2005414)

Mounting

Use the following procedure to mount the C2N-IO.

1. Use a #1 Phillips screwdriver and the included 4-40 x 1/4 in. screws to attach the mounting bracket to the C2N-IO as per the image below.

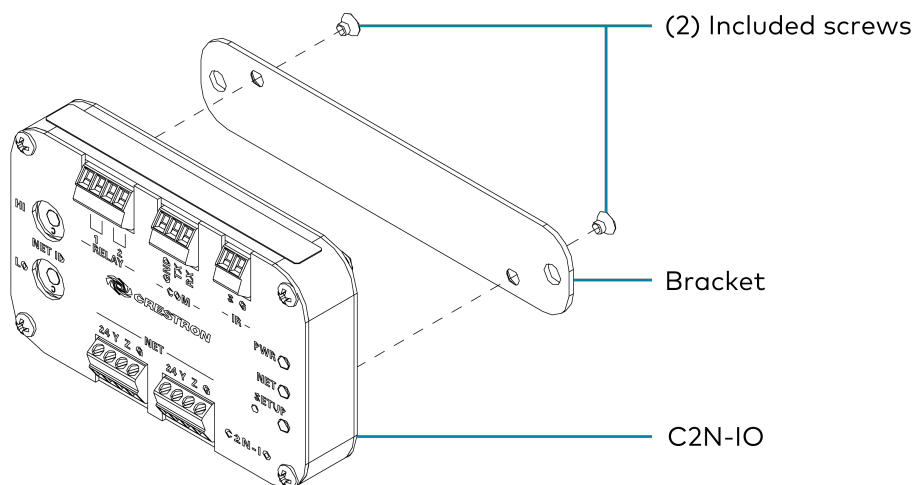

2. Mount the C2N-IO to a flat surface with two mounting screws (not included).

Hardware Hookup

Make the necessary connections as shown in the following illustration. Apply power after all connections have been made.

CAUTION: Incorrect wiring may damage the C2N-IO.

NOTE: The RS-232 COM port is intended for use with relatively simple devices that send and receive small packets and do not generate a lot of data. A small amount of delay may be normal when sending or receiving some control commands on a low-speed serial network. Cresnet networks with many devices tend to exhibit more delay.

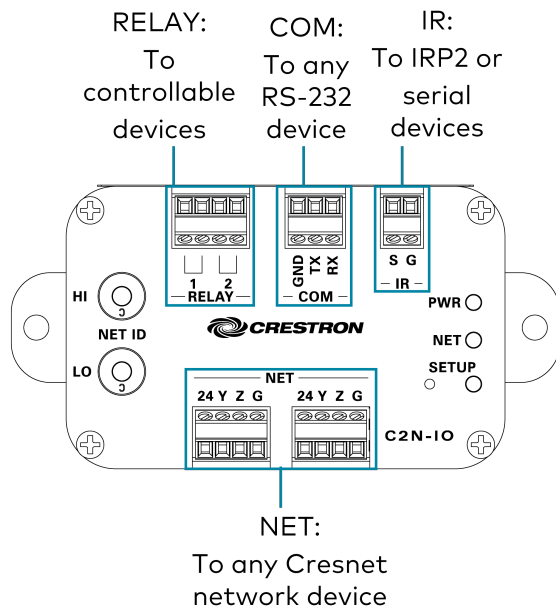

Connect with Zūm

When utilized with Zūm® wired lighting control applications and the Zūm Link communication bus, match the 24, Y, Z, G connections from the ZUMLINK-CONV-CN to the C2N-IO. The ZUMLINK-CONV-CN G output must be ground to Earth as well as to the C2N-IO G input. Make the necessary connections as per the image below.

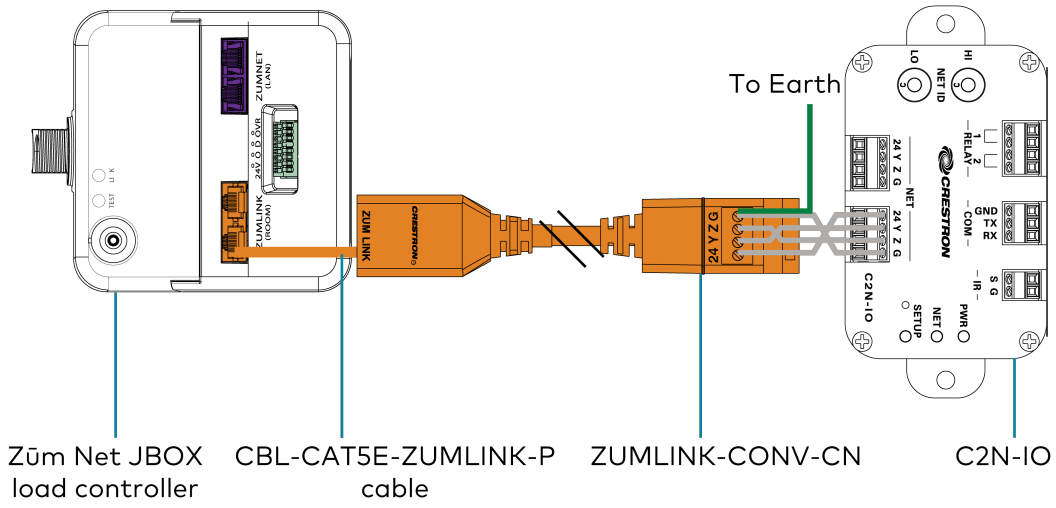

Configuration

The GLS-SIM can be configured to work with various device types. Use the DIP switches as described in the following images and tables to configure the device.

DIP Switches on GLS-SIM

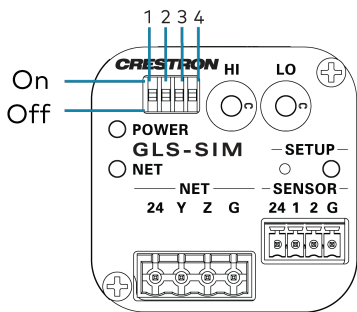

Input Channel	DIP Switch	Setting
1	1	OFF: Enables pull-up resistor ON: Disables pull-up resistor
	2	OFF: Normal polarity ON: Inverted polarity
2	3	OFF: Enables pull-up resistor ON: Disables pull-up resistor
	4	OFF: Normal polarity ON: Inverted polarity

Sensor Digital Input

The GLS-SIM can be configured for sensors that use relay contacts (normally open or normally closed) or voltage level (active high or active low). The digital input is rated for 0–24VDC, the input impedance is 18.5k ohms, and the logic threshold is 1.25VDC. Refer to the tables and wiring diagrams to configure the GLS-SIM.

Switch Settings for Digital Input (Dry Contact Closure)

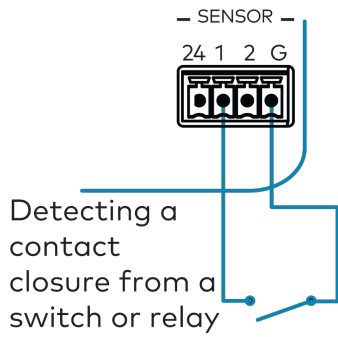

Input Channel DIP Switch Setting

1	1	OFF
	2	OFF: Normally open ON: Normally closed
2	3	OFF
	4	OFF: Normally open ON: Normally closed

Switch Settings for Digital Input (Voltage Detection)

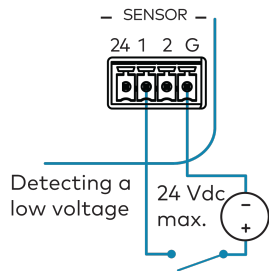

Input Channel DIP Switch Setting

1	1	ON
	2	OFF: Active low ON: Active high
2	3	ON
	4	OFF: Active low ON: Active high

Switch Settings for Digital Input

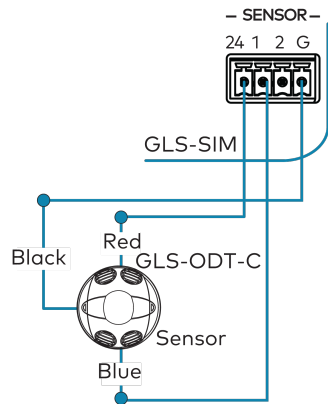

Input Channel DIP Switch Setting

Input Channel	DIP Switch	Setting
1	1	ON
	2	ON
2	3	ON
	4	ON

Analog Input

When using the GLS-SIM to read an analog input, set the DIP switches as shown in the tables and wiring diagrams to configure the GLS-SIM. The analog input is rated for 0–10VDC, protected to a maximum of 24VDC, and the input impedance is 18.5k ohms.

Switch Settings for Analog Input (Read Voltage from Analog Source)

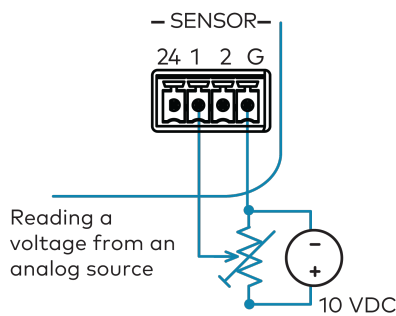

Input Channel DIP Switch Setting

Input Channel	DIP Switch	Setting
1	1	ON
	2	OFF
2	3	ON
	4	OFF

Setting switches 2 or 4 to ON inverts the polarity, causing the control signal to read "100%" at 0V and "0%" at 10V.

Switch Settings for Analog Input (Crestron Photocells, e.g., GLS-LCL and GLS-LOL)

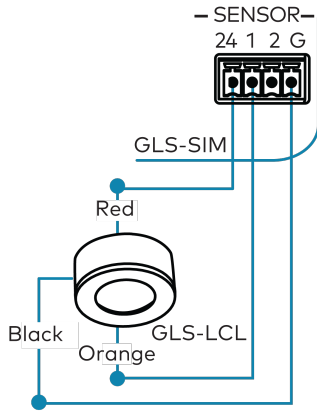

Input Channel DIP Switch Setting

Channel	Switch	Setting
1	1	ON
	2	OFF
2	3	ON
	4	OFF

Setting switches 2 or 4 to ON inverts the polarity, causing the control signal to read "100%" at 0V and "0%" at 10V.

Switch Settings for Analog Input (Read Resistance of Potentiometer)

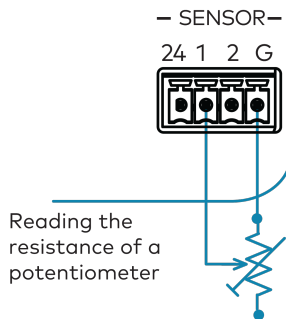

Input Channel DIP Switch Setting

Channel	Switch	Setting
1	1	OFF
	2	OFF
2	3	OFF
	4	OFF

Setting switches 2 or 4 to ON inverts the polarity, causing the control signal to read "100%" at 0V and "0%" at 10V.

Digital Output

When using the GLS-SIM as a digital output, set the DIP switches as shown in the table and wiring diagram. The digital output is a 250mA sink from a maximum of 24VDC, and catch diodes are used with "real world" loads.

Switch Settings for Digital Output (Drive a Relay Coil)

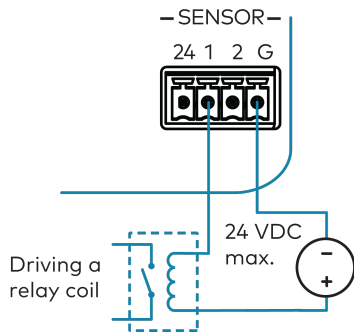

Input Channel DIP Switch Setting

1	1	ON
	2	OFF
2	3	ON
	4	OFF

Setting switches 2 or 4 to ON inverts the polarity, causing the control signal to read "100%" at 0V and "0%" at 10V.

Resources

The following resources are provided for the C2N-IO.

NOTE: You may need to provide your Crestron.com web account credentials when prompted to access some of the following resources.

Crestron Support and Training

- [Crestron True Blue Support](#)
- [Crestron Resource Library](#)
- [Crestron Online Help \(OLH\)](#)
- [Crestron Technical Institute \(CTI\) Portal](#)

Programmer and Developer Resources

- help.crestron.com: Provides help files for Crestron programming tools such as SIMPL, SIMPL#, and Crestron Toolbox™ software
- developer.crestron.com: Provides developer documentation for Crestron APIs, SDKs, and other development tools

Product Certificates

To search for product certificates, refer to the [Product Certificates](#) section of the Crestron Resource Library.

Related Documentation

- [Crestron Technical Documentation](#)

