

PW-5430DUS High-Efficiency Power Pack

The PW-5430DUS is an optional, high-efficiency power pack for Crestron® 3-Series® 4K DigitalMedia™ presentation systems and the DM 8G+® I/O blades (for example, the DMPS3-4K-350-C presentation system or the DMB-4K-O-C output blade).

The PW-5430DUS provides PoDM+ power (30 watts) to a maximum of four DM® endpoints on the blade, or PoDM power (15.4 watts) to all eight ports. When mixing PoDM and PoDM+ endpoints, the total power draw should not exceed 120 watts for optimal reliability. For more information, refer to Answer ID 5491 at support.crestron.com.

NOTE: Systems with multiple DM 8G+ blades require a dedicated PW-5430DUS for each individual blade.

Check the Box

Item	Qty
PW-5430DUS	1

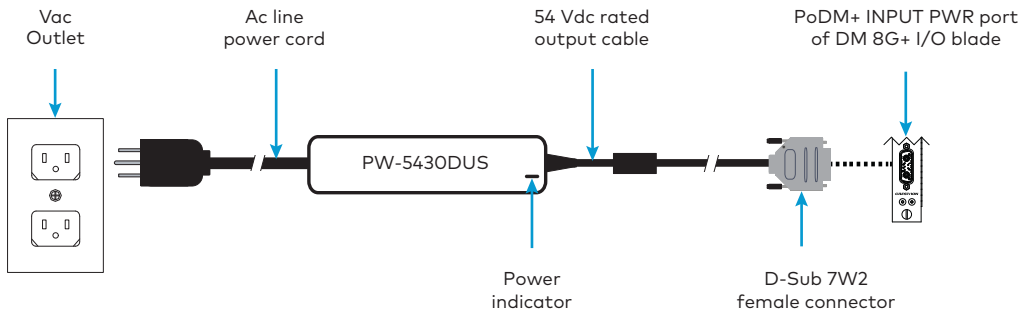

Connect the Power Pack

Connect the power pack.

1. Connect the D-Sub 7W2 female connector of the fixed 54 Vdc rated output cable to the PoDM+ INPUT PWR port of a DM 8G+ I/O blade.
2. Attach the included ac line power cord to the IEC connector on the power pack.
3. Insert the power pack's ac plug into an active ac outlet. The power indicator lights to indicate that the power pack is powered and functioning.



»» For Additional Information

Scan or click the QR code for detailed product information.



PW-5430DUS

Compliance and Legal

Original Instructions: The U.S. English version of this document is the original instructions. All other languages are a translation of the original instructions.

As of the date of manufacture, the product has been tested and found to comply with specifications for CE marking.



This product is Listed to applicable UL® Standards and requirements tested by Underwriters Laboratories Inc.

Ce produit est homologué selon les normes et les exigences UL applicables par Underwriters Laboratories Inc.



Industry Canada (IC) Compliance Statement

CAN ICES-3 (B)/NMB-3(B)

The product warranty can be found at www.crestron.com/warranty.

The specific patents that cover Crestron products are listed at www.crestron.com/legal/patents.

Certain Crestron products contain open source software. For specific information, please visit www.crestron.com/opensource.

Crestron, the Crestron logo, 3-Series, DigitalMedia, DM, and DM 8G+ are either trademarks or registered trademarks of Crestron Electronics, Inc. in the United States and/or other countries. UL and the UL logo are either trademarks or registered trademarks of Underwriters Laboratories, Inc. in the United States and/or other countries. Other trademarks, registered trademarks, and trade names may be used in this document to refer to either the entities claiming the marks and names or their products. Crestron disclaims any proprietary interest in the marks and names of others. Crestron is not responsible for errors in typography or photography.

©2019 Crestron Electronics, Inc.

Crestron Electronics, Inc.
15 Volvo Drive, Rockleigh, NJ 07647
Tel: 888.CRESTRON
Fax: 201.767.7576
www.crestron.com

**Quick Start - Doc. 8431B
(2053227)
02.19**

Specifications subject to
change without notice.