



View this document in HTML  
[crestron.com/docs/9507](http://crestron.com/docs/9507)



Product Manual

DIN-4DIMFLV4

4 Channel 0-10V Dimmer, 4 Feeds,  
DIN Rail Mount

The original language version of this document is U.S. English.  
All other languages are a translation of the original document.

Crestron product development software is licensed to Crestron dealers and Crestron Service Providers (CSPs) under a limited nonexclusive, nontransferable Software Development Tools License Agreement. Crestron product operating system software is licensed to Crestron dealers, CSPs, and end-users under a separate End-User License Agreement. Both of these Agreements can be found on the Crestron website at [www.crestron.com/legal/software\\_license\\_agreement](http://www.crestron.com/legal/software_license_agreement).

The product warranty can be found at [www.crestron.com/warranty](http://www.crestron.com/warranty).

The specific patents that cover Crestron products are listed online at [www.crestron.com/legal/patents](http://www.crestron.com/legal/patents).

Certain Crestron products contain open source software. For specific information, please visit [www.crestron.com/opensource](http://www.crestron.com/opensource).

Crestron, the Crestron logo, Cresnet, Crestron Home, and Crestron Toolbox are either trademarks or registered trademarks of Crestron Electronics, Inc. in the United States and/or other countries. Other trademarks, registered trademarks, and trade names may be used in this document to refer to either the entities claiming the marks and names or their products. Crestron disclaims any proprietary interest in the marks and names of others. Crestron is not responsible for errors in typography or photography.

©2024 Crestron Electronics, Inc.

# Contents

- Overview** ..... 1
- Specifications** ..... 2
- Wiring and Installation** ..... 3
  - Important Instructions ..... 3
  - Preparing and Connecting Wires ..... 3
  - Installing the DIN-4DIMFLV4 ..... 4
- Connections** ..... 5
  - Important Instructions ..... 5
- Operation** ..... 8
  - Net ID ..... 8
  - Manual Load Control ..... 8
  - Establish Override Mode Levels ..... 8
  - Toggle Override Mode ..... 9
  - Reboot the DIN-4DIMFLV4 ..... 9
- Troubleshooting** ..... 10
- Resources** ..... 11
  - Crestron Support and Training ..... 11
  - Programmer and Developer Resources ..... 11
  - Product Certificates ..... 11

# Overview

The Crestron® DIN-4DIMFLV4 is a 4-channel lighting control module designed to dim 0-10 V drivers and ballasts. A single model supports both 120 V and 220 V to 240 V applications. The DIN-4DIMFLV4 may also be used for switching of non-dimmable lighting loads up to 5 amps (may not be compatible with some high inrush current loads) and 1/2 HP motors.



# Specifications

## Load Ratings

---

<b>Dimmer Channels</b>	4
<b>Maximum Per Channel</b>	5 amps @ 120 to 240 Vac, 50/60 Hz; 600 W @ 120 Vac; 1150 W @ 230 Vac; 1200 W @ 240 Vac, 0.5 HP 16 amps Resistive
<b>Module Total</b>	20 amps @ 120 to 240 Vac, 50/60 Hz; 2400 W @ 120 Vac; 4600 W @ 230 Vac; 4800 W @ 240 Vac
<b>Dim Load Types</b>	0-10 V fluorescent ballast or LED driver (4-wire); Maximum of 30 dimmable ballasts/drivers
<b>Switch Load Types<sup>1</sup></b>	Incandescent, magnetic low-voltage, electronic low-voltage, neon/cold cathode, fluorescent, motors

## Power Requirements

---

<b>Cresnet® Power Usage</b>	4.2 W (0.18 amps) @ 24 Vdc
-----------------------------	----------------------------

## Enclosure

---

Light gray polycarbonate housing with polycarbonate label overlay, UL94 V-0 rated, 35 mm DIN EN 60715 rail mount, DIN 43880 form factor for enclosures with 45 mm front panel cutout, occupies 9 DIN module spaces (162 mm)

## Environmental

---

<b>Temperature</b>	32°F to 104°F (0°C to 40°C)
<b>Humidity</b>	10% to 90% RH (noncondensing)
<b>Heat Dissipation</b>	17 BTU/hr

## Dimensions

---

<b>Height</b>	43.71 in. (95 mm)
<b>Width</b>	6.26 in. (159 mm)
<b>Depth</b>	2.35 in. (60 mm)

## Weight

---

9.2 oz (260 g)

Note:

1. May not be compatible with some high inrush current loads.

# Wiring and Installation

## Important Instructions

**WARNING:** To avoid fire, shock, or death, turn off the power at the circuit breaker or fuse and test that the power is off before wiring.

**CAUTIONS:** This equipment is for indoor use only. Mount in a well-ventilated area. The ambient temperature must be 0°C to 40°C (32°F to 104°F). The relative humidity must be 10% to 90% (noncondensing).

### NOTES:

- Observe the following points:
  - Install and use the DIN-4DIMFLV4 in accordance with appropriate electrical codes and regulations.
  - A licensed electrician must install the DIN-4DIMFLV4.
- Before using the DIN-4DIMFLV4, ensure the device is using the latest firmware. Check for the latest firmware for the DIN-4DIMFLV4 at [www.crestron.com/firmware](http://www.crestron.com/firmware). Firmware is loaded onto the device using the Crestron Toolbox™ software or Crestron Home application.

## Preparing and Connecting Wires

When making the connections, strip the ends of the wires approximately 8 mm (1/3 in). Use care to avoid nicking the conductors. Tighten the connector to 0.5 - 0.6 Nm (5 in-lbs). The wire gauge should be 12 to 28 AWG.

# Installing the DIN-4DIMFLV4

The DIN-4DIMFLV4 should be used in a well-ventilated area. The venting holes should not be obstructed under any circumstances.

The DIN-4DIMFLV4 is designed for installation on a DIN rail. Refer to the diagram when installing.

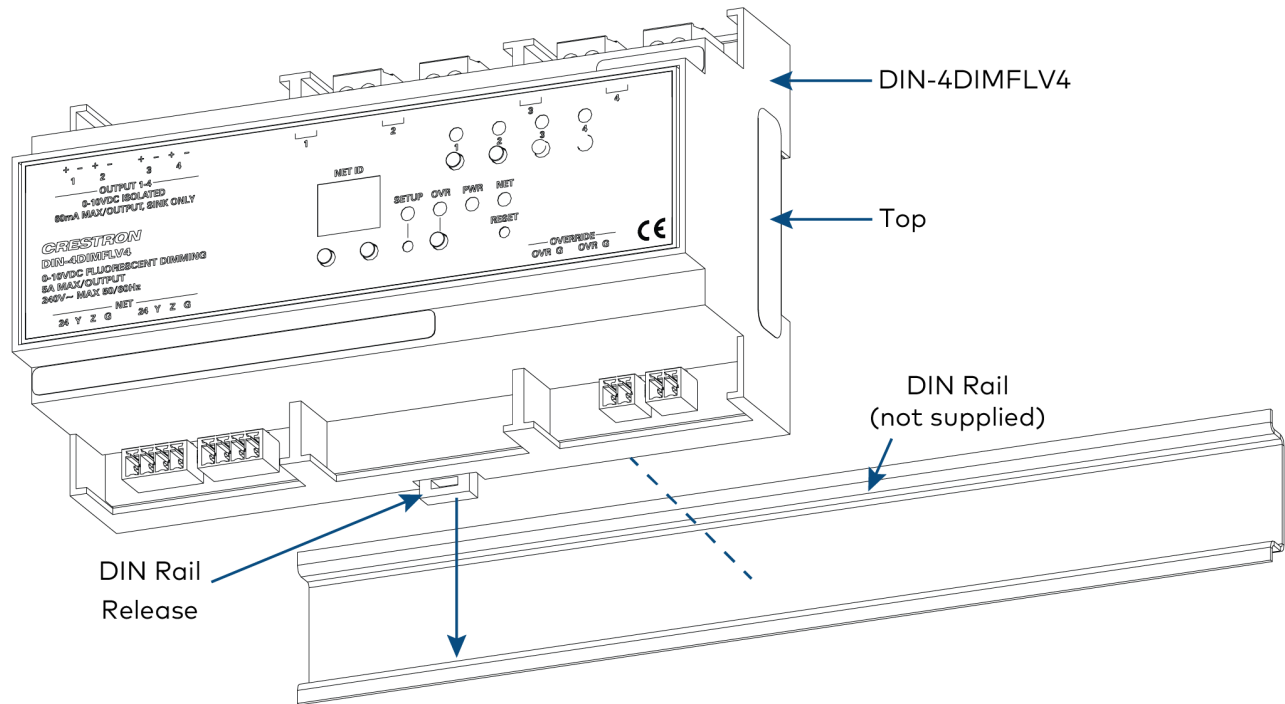

To install the DIN-4DIMFLV4:

1. Use a flat object (e.g., a flat-head screwdriver) to pull the DIN rail release downward.
2. Place the top of the DIN-4DIMFLV4's rail mount over the top of the DIN rail.
3. Tilt the bottom of the DIN-4DIMFLV4 toward the DIN rail until it snaps into place.

To remove the DIN-4DIMFLV4 from the DIN rail, use a small, flat object (e.g., a flat-head screwdriver) to pull the DIN rail release, and tilt the bottom of the DIN-4DIMFLV4 away from the DIN rail.

# Connections

## Important Instructions

**WARNING:** Prior to connecting the device, turn off the power at the circuit breaker. Failure to do so may result in serious personal injury or damage to the device. Restore power after all connections have been made.

**CAUTIONS:** Connecting this device to the wrong type of load or short-circuiting the load can cause severe product damage. Each load should be tested to identify a short-circuit condition prior to wiring the load to the module.

### NOTES:

- Install in accordance with all local and national electric codes.
- High-voltage connections accept 0.2 - 2.5 mm<sup>2</sup> (28 - 12 AWG) wire. Wire should be stripped to 8 mm (1/3 in). Tighten terminal blocks to 0.5 - 0.6 N-m (5 in-lbs).
- Use copper wire only. For high-voltage connections, use wires rated for at least 75°C (167°F).
- Each channel of the DIN-4DIMFLV4 may be fed from a separate circuit breaker or a single, shared breaker.

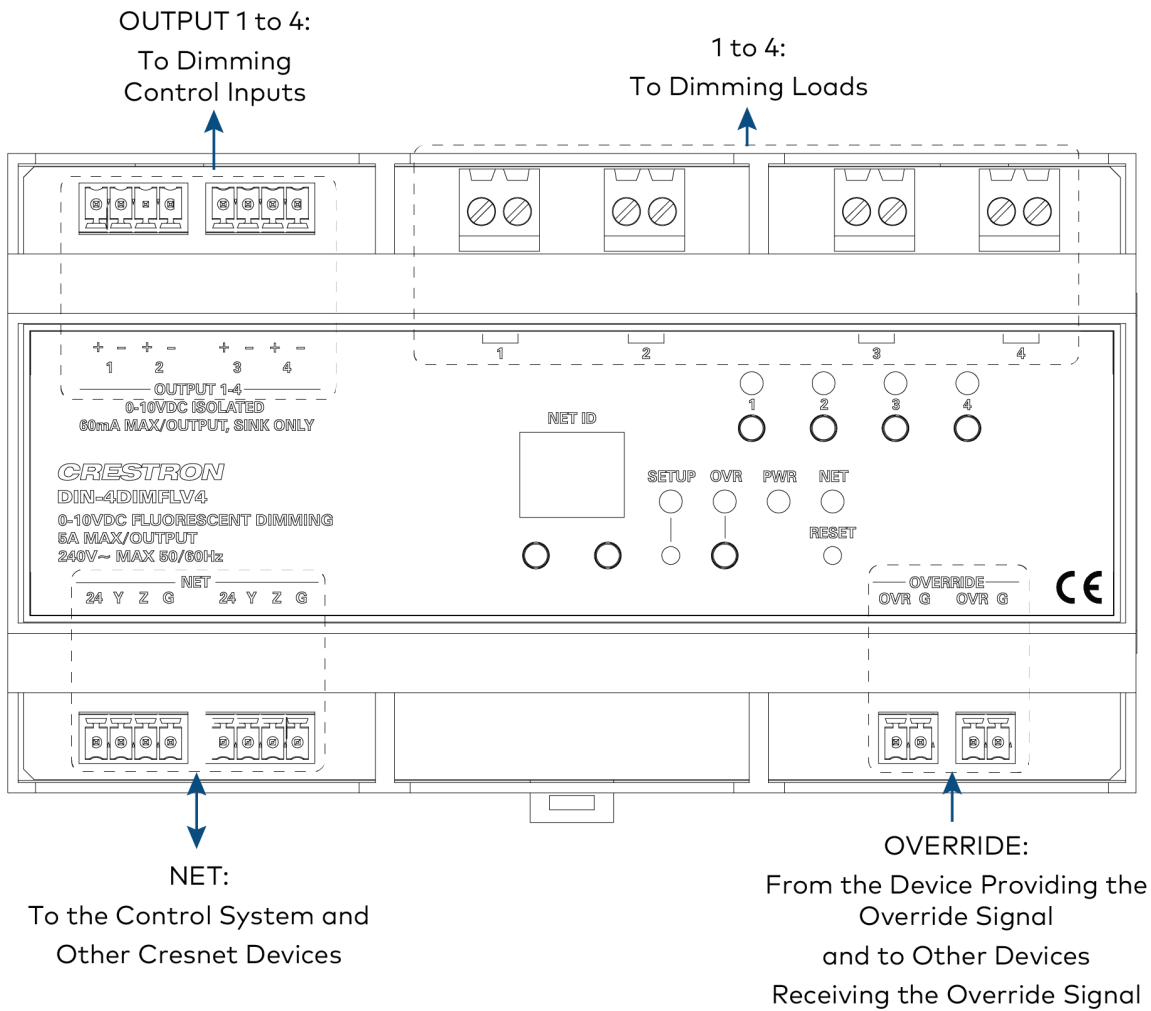

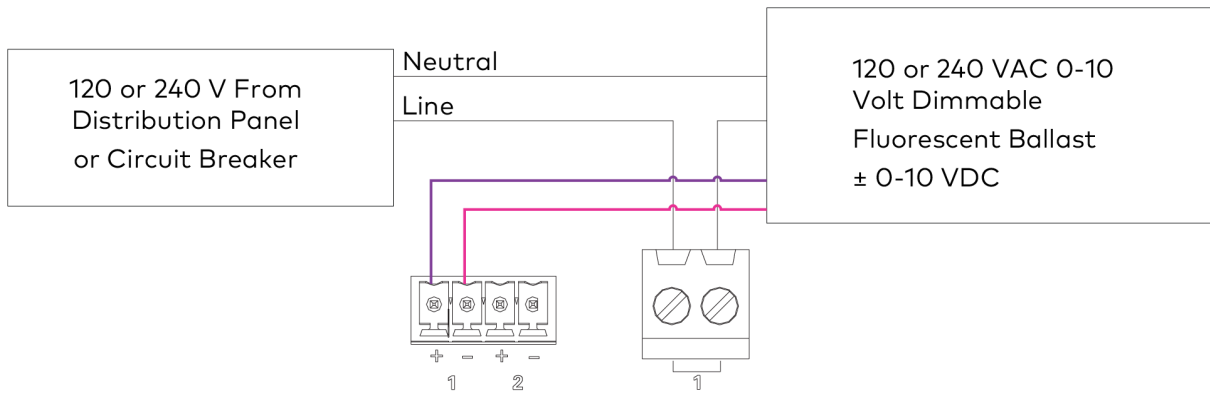

**NOTE:** Older wiring may be gray for DIM -.

# Operation

The DIN-4DIMFLV4 can be controlled via its front panel as well as from a control system. The following local controls are available.

## Net ID

Use the NET ID buttons to change the Net ID of the DIN-4DIMFLV4.

## Manual Load Control

The lighting level of each of the outputs can be manually controlled from the front panel. To toggle the light between off and 100% (on), tap an output button. The corresponding LED lights, and the output level is shown on the NET ID display ("oF" for off, "On" for on) for two seconds after the button is released.

To ramp the lighting level up or down (until it reaches a limit), press and hold the output button. To change the ramp direction, release the output button, and then press and hold it again. The corresponding LED lights, and the output level is shown on the NET ID display as a percentage (01 to 99) for two seconds after the button is released.

**NOTE:** The control system program may change the settings if Override mode is not enabled.

## Establish Override Mode Levels

Override mode disables the control system program and sets all of the lighting levels to the saved override values. The lighting level of each output can be saved as an override setting, which can be automatically recalled when the Override mode is enabled.

**NOTE:** The control system program has a setting that can prevent locally saving the override lighting level settings. If this setting is enabled, the display shows "Er" when saving the override lighting level settings.

To save the current lighting level as an override setting, set all of the load levels, and then press and hold the **OVR** button for three seconds. The OVR LED blinks to indicate that the new override setting has been saved.

# Toggle Override Mode

To enable Override mode, press and release the **OVR** button. The OVR LED blinks slowly. Override mode can also be toggled via a remote contact closure attached to the OVERRIDE port.

**NOTE:** If Override mode is enabled from an external device (i.e. a contact closure connected to the OVERRIDE port), the OVR LED blinks quickly when the local **OVR** button is pressed. Pressing the local **OVR** button has no effect when Override mode is toggled via the remote connection.

To disable Override mode, press the **OVR** button again. The OVR LED extinguishes, and the lights return to the levels set by the control system program.

**NOTE:** If the override lighting levels have not been saved, the factory default override level is 100%.

## Reboot the DIN-4DIMFLV4

To reboot the DIN-4DIMFLV4, press the **RESET** button. The outputs are set to the lighting levels currently specified by the control system program. If the control system does not provide any values, the outputs are set to the previously set lighting levels.

# Troubleshooting

The following table provides corrective actions for possible trouble situations. If further assistance is required, please contact a Crestron customer service representative.

TROUBLE	POSSIBLE CAUSE(S)	CORRECTIVE ACTION
The device does not function.	The device is not receiving power from a Crestron power source.	Use a Crestron power source. Verify that the connections are correct.
	The device is not receiving sufficient power.	Use the Cresnet Power Calculator to help calculate how much power is needed for the system.
	There is electrostatic discharge due to improper grounding.	Check that all the ground connections have been made properly.
The lamps stay at minimum intensity.	The + or - wires are reversed or shorted.	Verify that the polarity of the + and - wires at the ballasts/drivers and DIN-4DIMFLV4 are correct.
The lamps stay at maximum intensity.	The + or - wires are not connected.	Verify that the polarity of the + and - wires at the ballasts/drivers and DIN-4DIMFLV4 are correct.

# Resources

The following resources are provided for the DIN-4DIMFLV4.

**NOTE:** You may need to provide your Crestron.com web account credentials when prompted to access some of the following resources.

## Crestron Support and Training

- [Crestron True Blue Support](#)
- [Crestron Resource Library](#)
- [Crestron Online Help \(OLH\)](#)
- [Crestron Training Institute \(CTI\) Portal](#)

## Programmer and Developer Resources

- [help.crestron.com](http://help.crestron.com): Provides help files for Crestron programming tools such as SIMPL, SIMPL#, and Crestron Toolbox™ software
- [developer.crestron.com](http://developer.crestron.com): Provides developer documentation for Crestron APIs, SDKs, and other development tools

## Product Certificates

To search for product certificates, refer to the [Product Certificates](#) section of the Crestron Resource Library.

