



View this document in HTML
crestron.com/docs/9440



Product Manual

IV-CAM Series

Crestron 1 Beyond Cameras

Have feedback on this document? Contact docfeedback@crestron.com.

The original language version of this document is U.S. English.
All other languages are a translation of the original document.

Crestron product development software is licensed to Crestron dealers and Crestron Service Providers (CSPs) under a limited nonexclusive, nontransferable Software Development Tools License Agreement. Crestron product operating system software is licensed to Crestron dealers, CSPs, and end-users under a separate End-User License Agreement. Both of these Agreements can be found on the Crestron website at www.crestron.com/legal/software_license_agreement.

The product warranty can be found at www.crestron.com/warranty.

The specific patents that cover Crestron products are listed online at www.crestron.com/legal/patents.

Certain Crestron products collect information that may include personal data. For further details regarding those Crestron products that collect, process, and transmit information directly to Crestron via the Internet, please refer to the Crestron Privacy Statement Regarding Internet Data Collection, located at <http://www.crestron.com/legal-data-collection-privacy>.

This product is licensed under the Crestron Software End-User License Agreement, available at <https://www.crestron.com/Legal/software-license-agreement/Crestron-Software-End-User-License-Agreement>.

Certain Crestron products contain open source software. For specific information, please visit www.crestron.com/opensource.

Crestron and the Crestron logo are either trademarks or registered trademarks of Crestron Electronics, Inc. in the United States and/or other countries. HDMI is either a trademark or a registered trademark of HDMI Licensing LLC in the United States and/or other countries. Intertek and the Intertek logo are either trademarks or registered trademarks of Intertek Group in the United States and/or other countries. Microsoft Teams is either a trademark or a registered trademark of Microsoft Corporation in the United States and/or other countries. NDI is either a trademark or a registered trademark of NewTek, Inc. in the United States and/or other countries. Windows is either a trademark or a registered trademark of Microsoft Corporation in the United States and/or other countries. Zoom Rooms is either a trademark or registered trademark of Zoom Video Communications, Inc. in the United States and/or other countries. Other trademarks, registered trademarks, and trade names may be used in this document to refer to either the entities claiming the marks and names or their products. Crestron disclaims any proprietary interest in the marks and names of others. Crestron is not responsible for errors in typography or photography.

©2026 Crestron Electronics, Inc.

Contents

- IV-CAM Series 6**
- Features 7**
 - Camera Features 8
 - IV-CAM-P12 Features 9
 - IV-CAM-P20 Features 11
 - IV-CAM-P20-GV-B Features 13
 - IV-CAM-I12 Features 15
 - IV-CAM-I12-GV-B Features 17
 - IV-CAM-I20 Features 19
 - IV-CAM-I20-GV-B Features 21
 - IV-CAM-I12D-B Features 23
 - Camera Accessory Features 25
 - IV-CAMA-UMB Features 26
 - IVA-WMT-BRKT-1B Features 27
 - IVA-CMT-BRKTJ-1B Features 28
 - IV-CAMA-REMOTE Features 29
 - PW-1225DU Features 30
- Specifications 31**
 - Camera Specifications 32
 - IV-CAM-P12 Specifications 33
 - IV-CAM-P20 Specifications 39
 - IV-CAM-I12 Specifications 45
 - IV-CAM-I20 Specifications 51
 - IV-CAM-I12D-B Specifications 57
 - Camera Accessory Specifications 62
 - IV-CAMA-UMB Specifications 63
 - IVA-WMT-BRKT-1B Specifications 66
 - IVA-CMT-BRKTJ-1B Specifications 67
 - IV-CAMA-REMOTE Specifications 70
 - PW-1225DU Specifications 71
- Installation 72**
 - In The Box 73
 - IV-CAM-P12-B 73
 - IV-CAM-P12-W 73
 - IV-CAM-P20-B 73
 - IV-CAM-P20-W 74
 - IV-CAM-I12-B 74
 - IV-CAM-I20-B 74
 - IV-CAM-I20-W 74

IV-CAM-I12D-B	75
Mounting Requirements	76
Intelligent Camera Mounting	76
Mounting Measurements	77
Stacked Camera Mounting Distance	78
Install the Mounting Hardware	79
IV-CAMA-UMB Installation	80
IVA-WMT-BRKT-1B Installation	94
IVA-CMT-BRKTJ-1B Installation	97
Connect the Camera	100
Camera Ports	101
Network Connection	102
PoE Power	102
DC Power	102
Video Output	102
Serial Control	103
IV-CAM-I12D-B Installation	104
IV-CAM-I12D-B Installation Requirements	104
IV-CAM-I12D-B Tabletop Installation	104
IV-CAM-I12D-B Wall Installation	105
Connect the IV-CAM-I12D-B Camera	108
Camera Ports	108
Network Connection	108
Audio Reference	109
DC Power	109
Video Output	109
Serial Control	110
Configuration	111
Initial Setup	112
Install Camera Manager Software	113
Add Cameras	114
Set a Static IP Address	135
Update Firmware	138
Change the Camera Mode	142
Device Configuration	148
Accessing Camera Feeds	149
Camera Controls	156
Reserved Presets	160
On-Screen Display (OSD)	162
Advanced Camera Settings	176
Tracking Menu	191
Tracking Settings	219
Intelligent Switching	232
Intelligent Switching Design	233
Connection Requirements	234

Intelligent Switching Output	235
Visual Cue Intelligent Switching Configuration	236
Custom Intelligent Switching Configuration	242
Intelligent Switching Advanced Options	248
VISCA Commands	249
Call Camera Preset	249
ACK / Completion Messages	249
Error Messages	249
Commands	250
Inquiry Commands	254
VISCA Lightbar Commands	259
VISCA Intelligent Switching Commands	262
Perform a Factory Restore	265
Resources	266
Crestron Support and Training	266
Product Certificates	266

IV-CAM Series

Crestron 1 Beyond Cameras

The IV-CAM Series cameras are high quality PTZ cameras that output up to 1080p60 resolution video. Crestron 1 Beyond cameras are ideal for meetings in medium, large, and extra large spaces where one camera needs to capture several areas of the room. Intelligent features such as presenter tracking, group framing, and group tracking are available for IV-CAM-I12 and IV-CAM-I20 series cameras.

Features

Refer to the following sections for more information on the features provided by Crestron 1 Beyond cameras and accessories.

This section provides the following information:

- [Camera Features](#)
- [Camera Accessory Features](#)

Camera Features

Refer to the following sections for more information on the features provided by Crestron 1 Beyond cameras.

This section provides the following information:

- [IV-CAM-P12 Features](#)
- [IV-CAM-P20 Features](#)
- [IV-CAM-P20-GV-B Features](#)
- [IV-CAM-I12 Features](#)
- [IV-CAM-I12-GV-B Features](#)
- [IV-CAM-I20 Features](#)
- [IV-CAM-I20-GV-B Features](#)
- [IV-CAM-I12D-B Features](#)

IV-CAM-P12 Features

The [IV-CAM-P12](#) is a high quality PTZ camera that outputs up to 1080p60 resolution video. The IV-CAM-P12 is ideal for meetings in medium to large spaces where one camera needs to capture several areas of the room. The IV-CAM-P12 can be used with the [Crestron 1 Beyond Automate VX Series](#) as part of a complete multi-camera switching solution. The IV-CAM-P12 supports a single Ethernet connection and provides power (PoE), viewing, and control on a network.



- High quality video supporting resolutions up to 1080p60
- Compatible with Automate VX multi-camera systems
- Image flip allows for optional inverted mounting
- Single Ethernet connection provides power (PoE), viewing, control, and NDI®|HX2 video
- Easily configured with Crestron 1 Beyond Camera Manager 2 software
- Available in Moon Gray and Bright White colors

Automate VX Compatible

The IV-CAM-P12 camera is compatible with Automate VX multi-camera speaker tracking systems. Use the IV-CAM-P12 for close up shots of active speaking participants in medium to large spaces.

Certified for Conferencing Software

The IV-CAM-P12 camera is certified for Microsoft Teams® Rooms and Zoom Rooms® conferencing software. Use the rear USB port and connect a USB cable to a compatible codec for conferencing software use.

High Quality Video

A high quality Sony® CMOS sensor enables the camera to output up to 1080p60 resolution video.

Networked Power, Viewing, and Control

Connect a single Ethernet cable to power (PoE), view, set up, and control the IV-CAM-P12 camera.

Mounting Options

Standard mounting holes make it easy to mount the camera. The IV-CAM-P12 ships with the color matched [IV-CAMA-UMB](#) Universal Mounting Bracket, and is compatible with the [IVA-WMT-BRKT-1B](#) Wall Mount Bracket and the [IVA-CMT-BRKT-1B](#) J-Mount Ceiling Bracket (both sold separately).

IV-CAM-P20 Features

The [IV-CAM-P20](#) is a high quality PTZ camera that outputs up to 1080p60 resolution video. The IV-CAM-P20 is ideal for meetings in large to extra large spaces where one camera needs to capture several areas of the room. The IV-CAM-P20 can be used with the [Crestron 1 Beyond Automate VX Series](#) as part of a complete multi-camera switching solution. The IV-CAM-P20 supports a single Ethernet connection and provides power (PoE), viewing, and control on a network.



- High quality video supporting resolutions up to 1080p60
- Compatible with Automate VX multi-camera systems
- Image flip allows for optional inverted mounting
- Single Ethernet connection provides power (PoE), viewing, control, and NDI®|HX2 video
- Easily configured with Crestron 1 Beyond Camera Manager 2 software
- Available in Moon Gray and Bright White colors

Automate VX Compatible

The IV-CAM-P20 camera is compatible with Automate VX multi-camera speaker tracking systems. Use the IV-CAM-P20 for close up shots of active speaking participants in large to extra large spaces.

Certified for Conferencing Software

The IV-CAM-P20 camera is certified for Microsoft Teams® Rooms and Zoom Rooms® conferencing software. Use the rear USB port and connect a USB cable to a compatible codec for conferencing software use.

High Quality Video

A high quality Sony® CMOS sensor enables the camera to output up to 1080p60 resolution video.

Networked Power, Viewing, and Control

Connect a single Ethernet cable to power (PoE), view, set up, and control the IV-CAM-P20 camera.

Mounting Options

Standard mounting holes make it easy to mount the camera. The IV-CAM-P20 ships with the color matched [IV-CAMA-UMB](#) Universal Mounting Bracket, and is compatible with the [IVA-WMT-BRKT-1B](#) Wall Mount Bracket and the [IVA-CMT-BRKT-1B](#) J-Mount Ceiling Bracket (both sold separately).

IV-CAM-P20-GV-B Features

The [IV-CAM-P20-GV-B](#) is a high quality PTZ camera that outputs up to 1080p60 resolution video. The IV-CAM-P20-GV-B is ideal for meetings in where one camera needs to capture several areas of the room. The IV-CAM-P20-GV-B can be used with the [Crestron 1 Beyond Automate VX Series](#) as part of a complete multi-camera switching solution. The IV-CAM-P20-GV-B supports a single Ethernet connection and provides power (PoE), viewing, and control on a network.

The IV-CAM-P20-GV-B is a TAA-compliant camera that is suitable for government deployments.



- High quality video supporting resolutions up to 1080p60
- Compatible with Automate VX multi-camera systems
- Image flip allows for optional inverted mounting
- Single Ethernet connection provides power (PoE), viewing, control, and NDI®|HX2 video
- Easily configured with Crestron 1 Beyond Camera Manager 2 software
- Available in Moon Gray and Bright White colors

Automate VX Compatible

The IV-CAM-P20-GV-B camera is compatible with Automate VX multi-camera speaker tracking systems. Use the IV-CAM-P20-GV-B for close up shots of active speaking participants in large to extra large spaces.

Certified for Conferencing Software

The IV-CAM-P20-GV-B camera is certified for Microsoft Teams® Rooms and Zoom Rooms® conferencing software. Use the rear USB port and connect a USB cable to a compatible codec for conferencing software use.

High Quality Video

A high quality Sony® CMOS sensor enables the camera to output up to 1080p60 resolution video.

Networked Power, Viewing, and Control

Connect a single Ethernet cable to power (PoE), view, set up, and control the IV-CAM-P20-GV-B camera.

Mounting Options

Standard mounting holes make it easy to mount the camera. The IV-CAM-P20-GV-B ships with the color matched [IV-CAMA-UMB](#) Universal Mounting Bracket, and is compatible with the [IVA-WMT-BRKT-1B](#) Wall Mount Bracket and the [IVA-CMT-BRKT-1B](#) J-Mount Ceiling Bracket (both sold separately).

IV-CAM-I12 Features

The [IV-CAM-I12-B](#) is a high quality intelligent PTZ camera that uses visual AI to automatically track or frame meeting participants. The IV-CAM-I12 is ideal for group framing meeting participants in medium to large spaces, and presenter tracking in medium sized presentation areas. The IV-CAM-I12 has a dual camera design; the wide-angle reference camera uses visual AI to direct the PTZ camera. All visual AI is built into the camera—no external system is needed.



- Visual AI for Group Framing or Presenter Tracking
- High quality video supporting resolutions up to 1080p60
- Automatically pans, tilts, and zooms with dual camera technology, no external computer required
- Supports 12x optical zoom for tracking distances up to 25 ft from participants
- Connects directly to a codec or recording/streaming device
- Single Ethernet connection provides power (PoE), viewing, and control
- Easily configured with Crestron 1 Beyond Camera Manager software
- Compatible with Automate VX multi-camera systems
- Compatible with Crestron 1 Beyond IR Camera Remote

Group Framing Technology

Group framing utilizes visual AI to frame multiple participants smoothly in medium to large conference rooms. The wide-angle reference camera tracks participant movement, and the PTZ camera automatically reframes to keep them in view.

Presenter Tracking Capability

Visual AI is used to smoothly track a single moving presenter as they move through a designated presentation area. It is easily configurable to prevent tracking other subjects or displays by using Blocking Zones. The recommended tracking range is 10 to 25 ft from the presentation area.

Multi-Camera Switching Capability

Two Crestron intelligent cameras can be set up to utilize intelligent switching. One camera can be designated as a group framing camera ([IV-CAM-I12](#)), and the other can be used as a presenter tracking camera ([IV-CAM-I12](#) or [IV-CAM-I20](#)). This feature allows for seamless transition between the group framing camera and the presenter tracking camera when someone enters the presentation zone—no additional hardware or software required.

Automate VX Compatible

The IV-CAM-I12 camera is compatible with Automate VX multi-camera speaker tracking systems. Use the IV-CAM-I12 for close up shots of active speaking participants, and for presenter tracking in a designated area within 25 ft.

Certified for Conferencing Software

The IV-CAM-I12 camera is certified for Microsoft Teams® Rooms and Zoom Rooms® conferencing software. Use the rear USB port and connect a USB cable to a compatible codec for conferencing software use.

High Quality Video

A high quality Sony® CMOS sensor enables the camera to output up to 1080p60 resolution video.

Networked Power, Viewing, and Control

Connect a single Ethernet cable to power (PoE), view, set up, and control the IV-CAM-I12 camera.

Mounting Options (Sold Separately)

Standard mounting holes make it easy to mount the camera. The IV-CAM-I12 is compatible with the [IV-CAMA-UMB](#) Universal Mounting Bracket, [IVA-WMT-BRKT-1B](#) Wall Mount Bracket, and [IVA-CMT-BRKT-1B](#) J-Mount Ceiling Bracket.

IV-CAM-I12-GV-B Features

The [IV-CAM-I12-GV-B](#) is a high quality intelligent PTZ camera that uses visual AI to automatically track or frame a presenter. The IV-CAM-I12-GV-B is ideal for group framing meeting participants in medium to large spaces, and presenter tracking in medium sized presentation areas. The IV-CAM-I12-GV-B has a dual camera design; the wide-angle reference camera uses visual AI to direct the PTZ camera. All visual AI is built into the camera—no external system is needed.

The IV-CAM-I12-GV-B is a TAA-compliant camera that is suitable for government deployments.



- TAA compliant for government deployments
- Visual AI for Group Framing or Presenter Tracking
- High quality video supporting resolutions up to 1080p60
- Automatically pans, tilts, and zooms with dual camera technology, no external computer required
- Supports 12x optical zoom for tracking distances up to 25 ft from participants
- Connects directly to a codec or recording/streaming device
- Single Ethernet connection provides power (PoE), viewing, and control
- Easily configured with Crestron 1 Beyond Camera Manager software
- Compatible with Automate VX multi-camera systems
- Compatible with Crestron 1 Beyond IR Camera Remote

Group Framing Technology

Group framing utilizes visual AI to frame multiple participants smoothly in medium to large conference rooms. The wide-angle reference camera tracks participant movement, and the PTZ camera automatically reframes to keep them in view.

Presenter Tracking Capability

Visual AI is used to smoothly track a single moving presenter as they move through a designated presentation area. It is easily configurable to prevent tracking other subjects or displays by using Blocking Zones. The recommended tracking range is 10 to 25 ft from the presentation area.

Multi-Camera Switching Capability

Two Crestron intelligent cameras can be set up to utilize intelligent switching. One camera can be designated as a group framing camera ([IV-CAM-I12](#)), and the other can be used as a presenter tracking camera ([IV-CAM-I12](#) or [IV-CAM-I20](#)). This feature allows for seamless transition between the group framing camera and the presenter tracking camera when someone enters the presentation zone—no additional hardware or software required.

Automate VX Compatible

The IV-CAM-I12-GV-B camera is compatible with Automate VX multi-camera speaker tracking systems. Use the IV-CAM-I12-GV-B for close up shots of active speaking participants, and for presenter tracking in a designated area within 25 ft.

Certified for Conferencing Software

The IV-CAM-I12-GV-B camera is certified for Microsoft Teams® Rooms and Zoom Rooms® conferencing software. Use the rear USB port and connect a USB cable to a compatible codec for conferencing software use.

High Quality Video

A high quality Sony® CMOS sensor enables the camera to output up to 1080p60 resolution video.

Networked Power, Viewing, and Control

Connect a single Ethernet cable to power (PoE), view, set up, and control the IV-CAM-I12-GV-B camera.

Mounting Options (Sold Separately)

Standard mounting holes make it easy to mount the camera. The IV-CAM-I12-GV-B is compatible with the [IV-CAMA-UMB](#) Universal Mounting Bracket, [IVA-WMT-BRKT-1B](#) Wall Mount Bracket, and [IVA-CMT-BRKT-1B](#) J-Mount Ceiling Bracket.

IV-CAM-I20 Features

The [IV-CAM-I20](#) is a high quality intelligent PTZ camera that uses visual AI to automatically track or frame a presenter. The IV-CAM-I20 is ideal for presenter tracking in large to extra large sized training rooms and classrooms, and group tracking meeting participants in large to extra large conference rooms. The IV-CAM-I20 has a dual camera design; the wide-angle reference camera uses visual AI to direct the PTZ camera. All visual AI is built into the camera—no external system is needed.



- Visual AI for Presenter Tracking
- High quality video supporting resolutions up to 1080p60
- Automatically pans, tilts, and zooms with dual camera technology, no external computer required
- Supports 20x optical zoom for tracking distances up to 50 ft from participants
- Connects directly to a codec or recording/streaming device
- Single Ethernet connection provides power (PoE), viewing, control, and NDI®|HX2 video
- Easily configured with Crestron 1 Beyond Camera Manager software
- Compatible with Automate VX multi-camera systems
- Available in Moon Gray and Bright White colors

Presenter Tracking Capability

Visual AI is used to smoothly track a single moving presenter as they move through a designated presentation area. It is easily configurable to prevent tracking other subjects or displays by using Blocking Zones. The recommended tracking range is 15 to 50 ft from the presentation area.

Group Tracking Technology

Group Tracking utilizes visual AI to track multiple presenters smoothly in large training rooms and classrooms. The wide-angle reference camera tracks participant movement, and the PTZ camera pans, tilts, and zooms to keep all presenters in the frame.

Preset Zones

Preset Zones utilizes visual AI to frame a dedicated area of the room. When a participant enters the Preset Zone, the camera automatically displays the area regardless of who is currently talking or where other participants may be.

Automate VX Compatible

The IV-CAM-I20 camera is compatible with Automate VX multi-camera speaker tracking systems. Use the IV-CAM-I20 presenter tracking in a designated area within 25 50ft.

Certified for Conferencing Software

The IV-CAM-I20 camera is certified for Microsoft Teams® Rooms and Zoom Rooms® conferencing software. Use the rear USB port and connect a USB cable to a compatible codec for conferencing software use.

High Quality Video

A high quality Sony® CMOS sensor enables the camera to output up to 1080p60 resolution video.

Networked Power, Viewing, and Control

Connect a single Ethernet cable to power (PoE), view, set up, and control the IV-CAM-I20 camera.

Mounting Options

Standard mounting holes make it easy to mount the camera. The IV-CAM-I20 ships with the color matched [IVA-WMT-BRKT-1B](#) Wall Mount Bracket, and is compatible with the [IV-CAMA-UMB](#) Universal Mounting Bracket and the [IVA-CMT-BRKT-1B](#) J-Mount Ceiling Bracket (both sold separately).

IV-CAM-I20-GV-B Features

The [IV-CAM-I20-GV-B](#) is a high quality intelligent PTZ camera that uses visual AI to automatically track or frame a presenter. The IV-CAM-I20-GV-B is ideal for presenter tracking in large to extra large sized training rooms and classrooms, and group tracking meeting participants in large to extra large conference rooms. The IV-CAM-I20-GV-B has a dual camera design; the wide-angle reference camera uses visual AI to direct the PTZ camera. All visual AI is built into the camera—no external system is needed.

The IV-CAM-I20-GV-B is a TAA-compliant camera that is suitable for government deployments.



- Visual AI for Presenter Tracking
- High quality video supporting resolutions up to 1080p60
- Automatically pans, tilts, and zooms with dual camera technology, no external computer required
- Supports 20x optical zoom for tracking distances up to 50 ft from participants
- Connects directly to a codec or recording/streaming device
- Single Ethernet connection provides power (PoE), viewing, control, and NDI®|HX2 video
- Easily configured with Crestron 1 Beyond Camera Manager software
- Compatible with Automate VX multi-camera systems
- Available in Moon Gray and Bright White colors

Presenter Tracking Capability

Visual AI is used to smoothly track a single moving presenter as they move through a designated presentation area. It is easily configurable to prevent tracking other subjects or displays by using Blocking Zones. The recommended tracking range is 15 to 50 ft from the presentation area.

Group Tracking Technology

Group Tracking utilizes visual AI to track multiple presenters smoothly in large training rooms and classrooms. The wide-angle reference camera tracks participant movement, and the PTZ cameras pans, tilts, and zooms to keep all presenters in the frame.

Preset Zones

Preset Zones utilizes visual AI to frame a dedicated area of the room. When a participant enters the Preset Zone, the camera automatically displays the area regardless of who is currently talking or where other participants may be.

Automate VX Compatible

The IV-CAM-I20-GV-B camera is compatible with Automate VX multi-camera speaker tracking systems. Use the IV-CAM-I20-GV-B presenter tracking in a designated area within 25 50ft.

Certified for Conferencing Software

The IV-CAM-I20-GV-B camera is certified for Microsoft Teams® Rooms and Zoom Rooms® conferencing software. Use the rear USB port and connect a USB cable to a compatible codec for conferencing software use.

High Quality Video

A high quality Sony® CMOS sensor enables the camera to output up to 1080p60 resolution video.

Networked Power, Viewing, and Control

Connect a single Ethernet cable to power (PoE), view, set up, and control the IV-CAM-I20-GV-B camera.

Mounting Options

Standard mounting holes make it easy to mount the camera. The IV-CAM-I20-GV-B ships with the color matched [IVA-WMT-BRKT-1B](#) Wall Mount Bracket, and is compatible with the [IV-CAMA-UMB](#) Universal Mounting Bracket and the [IVA-CMT-BRKT-1B](#) J-Mount Ceiling Bracket (both sold separately).

IV-CAM-I12D-B Features

The [IV-CAM-I12D-B](#) is an intelligent speaker tracking solution that utilizes a pair of 4K PTZ cameras to automatically follow the active speaking participant. Featuring a 4K reference camera and integrated microphone array for spatial audio detection, the IV-CAM-I12D-B is suited for medium to large spaces requiring close-up views of speaking participants. Capable of speaker tracking, group framing, and dynamic composition camera shots, the IV-CAM-I12D-B fits perfectly into a meeting space. All Visual AI is built into the camera — no external system is needed.



- Visual AI for speaker tracking and group framing
- Automatically pans, tilts, and zooms with dual cameras, no external system required
- High quality cameras supporting resolutions up to 4K30
- Supports 12x optical zoom for speaker tracking distances up to 25 ft from participants
- Connects directly to a codec running Microsoft Teams® or Zoom Rooms™ software
- Easily configured with Crestron 1 Beyond Camera Manager 2 software
- Single Ethernet connection provides viewing and control
- Serves as the primary camera for Intelligent Switching
- Compatible with a variety of audio solutions
- Dynamic lightbar that displays the current camera status

Speaker Tracking Technology

Speaker tracking uses voice and facial detection to automatically switch to a camera shot of the active speaking participant. With two 4K PTZ cameras available, the IV-CAM-I12D-B allows remote participants to follow an in-room conversation without seeing camera movement.

Group Framing Capability

Group framing utilizes Visual AI to frame multiple participants smoothly in medium to large conference rooms. The wide-angle reference camera continuously detects when participants enter or leave the camera shot, and the PTZ camera reframes the shot automatically to fit participants.

Customizable Composition Camera Shots

Change the layout of the camera output to create the desired experience. Switch between full-screen, picture-in-picture, and Conversation Mode layouts to ensure that all speaking participants are shown to remote viewers. Customize the picture-in-picture location, Conversation Mode's properties, and speaker tracking properties in the [Crestron 1 Beyond Camera Manager 2 software](#).

Intelligent Switching Capability

The IV-CAM-I12D-B serves as the primary camera for Intelligent Switching configurations. Combine this camera with up to four other Crestron 1 Beyond cameras for an automated camera switching experience. Intelligent Switching can change the camera output based on either Visual Cues or Custom Cues depending on the desired experience.

Combine with Microphones and Speakers

The IV-CAM-I12D-B works with a variety of microphones and audio speakers. Connect existing in-room audio devices to the AES67 or AUDIO REF inputs on the camera to prevent unwanted speaker tracking detection.

Conferencing Compatibility

The IV-CAM-I12D-B camera is compatible with Microsoft Teams® and Zoom Rooms™ conferencing software. Use the rear USB port to connect a USB cable to a compatible codec for conferencing software use.

Networked Viewing and Control

Connect a single Ethernet cable to view, set up, and control the IV-CAM-I12D-B camera.

High Quality 4K Video

A high quality Sony® CMOS sensor enables the camera to output up to 4K30 resolution video.

Dynamic Lightbar Indicator

The lightbar on the front of the camera dynamically changes color and length depending on which mode the camera is currently in, providing immediate feedback about camera operation.

Camera Accessory Features

Refer to the following sections for more information on the features provided by Crestron 1 Beyond accessories.

This section provides the following information:

- [IV-CAMA-UMB Features](#)
- [IVA-WMT-BRKT-1B Features](#)
- [IVA-CMT-BRKTJ-1B Features](#)
- [IV-CAMA-REMOTE Features](#)
- [PW-1225DU Features](#)

IV-CAMA-UMB Features

The [IV-CAMA-UMB](#) Universal Mount Bracket provides an all in one mounting solution for Crestron 1 Beyond cameras. The IV-CAMA-UMB can be mounted upright, inverted to the wall, or inverted to the ceiling. The [IV-CAM-P20](#), [IV-CAM-P12](#), [IV-CAM-I20](#), and [IV-CAM-I12-B](#) cameras are compatible with the wall mount configuration, and the inverted ceiling mount configuration is only compatible with the IV-CAM-P20 and IV-CAM-P12 cameras.



IVA-WMT-BRKT-1B Features

The [IVA-WMT-BRKT-1B](#) Wall Mount Bracket provides a secure wall mounting option for [IV-CAM-P20](#), [IV-CAM-P12](#), [IV-CAM-I20](#), and [IV-CAM-I12-B](#) cameras. The IVA-WMT-BRKT-1B comes with an adjustable swivel head that positions the camera at a desired angle to capture the optimal view of participants.



IVA-CMT-BRKTJ-1B Features

The [IVA-CMT-BRKTJ-1B](#) J-Mount Ceiling Bracket provides an easy mounting solution for [IV-CAM-P20](#), [IV-CAM-P12](#), [IV-CAM-I20](#), and [IV-CAM-I12-B](#) cameras. The IVA-CMT-BRKTJ-1B can be used in spaces where the camera has to be suspended from the ceiling to achieve optimal distance from the presentation area.

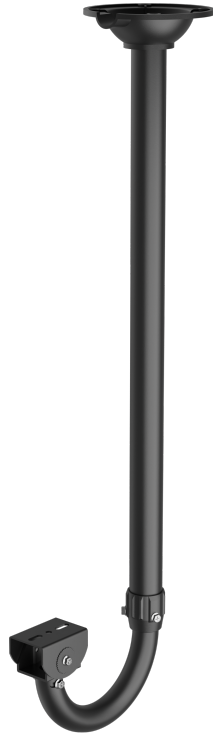

IV-CAMA-REMOTE Features

The [IV-CAMA-REMOTE](#) is an IR wireless remote designed to be used with [IV-CAM-I12-B](#) cameras. The IV-CAMA-REMOTE provides full access to camera video settings, calling predefined camera presets, and enabling or disabling camera tracking.



PW-1225DU Features

The [PW-1225DU](#) is a 12 VDC universal regulated power pack intended for use with Crestron 1 Beyond [IV-CAM-P20](#), [IV-CAM-P12](#), [IV-CAM-I20](#), and [IV-CAM-I12-B](#) cameras.



Specifications

Refer to the following sections for more information on the specifications of the Crestron 1 Beyond cameras and accessories.

This section provides the following information:

- [Camera Specifications](#)
- [Camera Accessory Specifications](#)

Camera Specifications

Refer to the following sections for more information on the specifications of the Crestron 1 Beyond cameras.

This section provides the following information:

- [IV-CAM-P12 Specifications](#)
- [IV-CAM-P20 Specifications](#)
- [IV-CAM-I12 Specifications](#)
- [IV-CAM-I20 Specifications](#)
- [IV-CAM-I12D-B Specifications](#)

IV-CAM-P12 Specifications

Product specifications for the IV-CAM-P12 are provided below.

Specifications

Optics and Processing

Image Sensor	1/2.8 Sony® CMOS Sensor
Optical Zoom	12x
Focal Length	F=4.1–49.2 mm
Field of View	Horizontal: 67.68°
Shutter Speed	1/50-1/10,000 sec
Iris	F1.8-F2.68
Minimum Illumination	2 lux
Pan/Tilt Angle	Pan: -130° – 130°, Tilt: -30° – 90°
Pan/Tilt Speed	Pan: 0.2° – 90°/s, Tilt: 0.2° – 70°/s
Presets	Up to 256 configurable presets
White Balance	Auto, Indoor, One Push, Manual
Exposure	Auto, Manual, Shutter Priority, Iris Priority, Brightness Priority
Signal to Noise Ratio	≥50dB

Video

Video Outputs	3G-SDI, HDMI®, USB, NDI® HX2, ONVIF, RTSP, UVC
Signal Formats	SDI or HDMI: 1080p60/59.94/50/30/ 29.94/25, 720p60/59.94/50; USB (NV12 and MJPEG): 1080p30/25, 720p30/25, 360p30

Communications

Ethernet	RJ-45, 100Mbps
Serial	RS-232, RS-485
Control Protocol	VISCA/TCP, VISCA/UDP, PELCO-D, PELCO-P, ONVIF

Management Client

Software	Crestron 1 Beyond Camera Manager 2 (Windows® OS computer required)
-----------------	--

Connectors

COM	(1) 5-pin 3.5 mm detachable terminal block; Bidirectional RS-232/485 port
PoE	(1) 8-pin RJ-45 connector, female
3G-SDI OUT	(1) BNC connector, female; 3G-SDI digital video output
HDMI OUT	(1) HDMI Type A connector; HDMI digital video output
USB	(1) USB Type B connector, female; USB 3.0 device port for video and control; USB 2.0 device port for video (MJPEG only) and control
12VDC 2.5A	(1) 3.3 mm DC power connector; 12VDC power input; PW-1225DU power pack sold separately

Controls and Indicators

Status Bar	(1) Multisegment tricolor LED bargraph; Half green LED bargraph indicates live camera feed; Full amber LED bargraph indicates firmware upgrade; Half red LED bargraph indicates Privacy Mode
RESET	(1) Recessed push button for hardware reset

Power

Power Source Options	Ethernet (PoE), Power Pack (PW-1225DU)
Power over Ethernet	IEEE 802.3af Class 3 Powered Device
Power over Ethernet Rating	15.4 W

NOTE: To comply with the European Directive (CE), shielded CAT5e cable must be used as a minimum for PoE power.

Power Pack (sold separately)	12VDC, 2.5A, 50/60 Hz
-------------------------------------	-----------------------

Environmental

Temperature	32° to 104°F (0° to 40°C)
Humidity	10% to 90% RH (noncondensing)

Construction

Mounting Options	IV-CAMA-UMB 1 Beyond Universal Mounting Bracket (included), IVA-WMT-BRKT-1B 1 Beyond Wall Mount Bracket (sold separately), IVA-CMT-BRKTJ-1B 1 Beyond J-Mount Bracket (sold separately)
Mounting Thread	1/4 in. threaded mount hole

Dimensions

Height	6.55 in. (166 mm)
Width	8.89 in. (226 mm)
Depth	5.86 in. (149 mm)

Weight

4.12 lb (1.87 kg)

Compliance

Regulatory Model: M202306003

FCC Part 15 Class B, IC Class B, CE, Intertek® Listed for US and Canada

Dimension Drawings

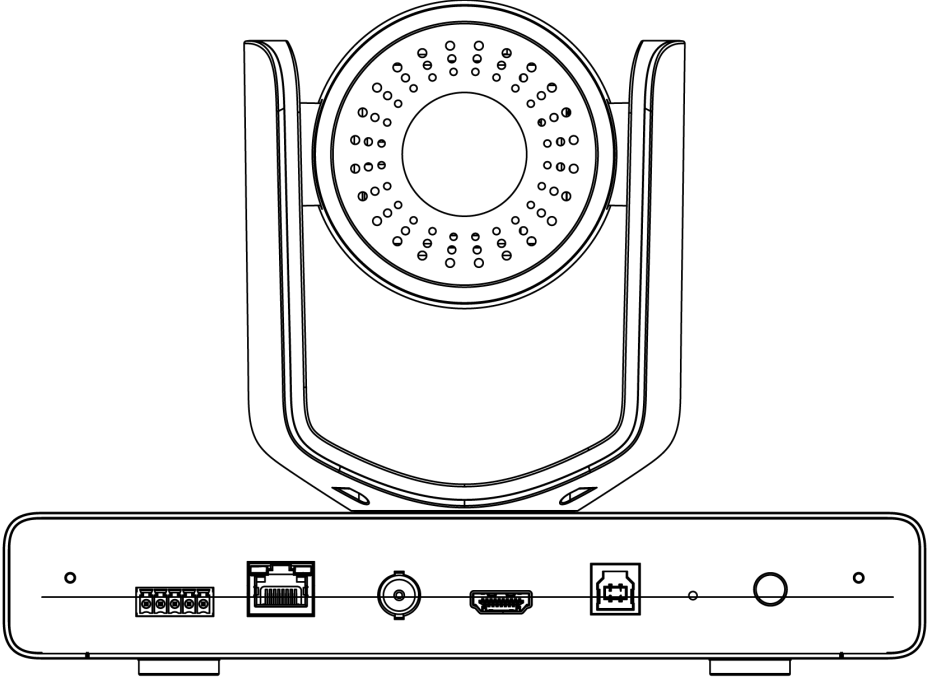
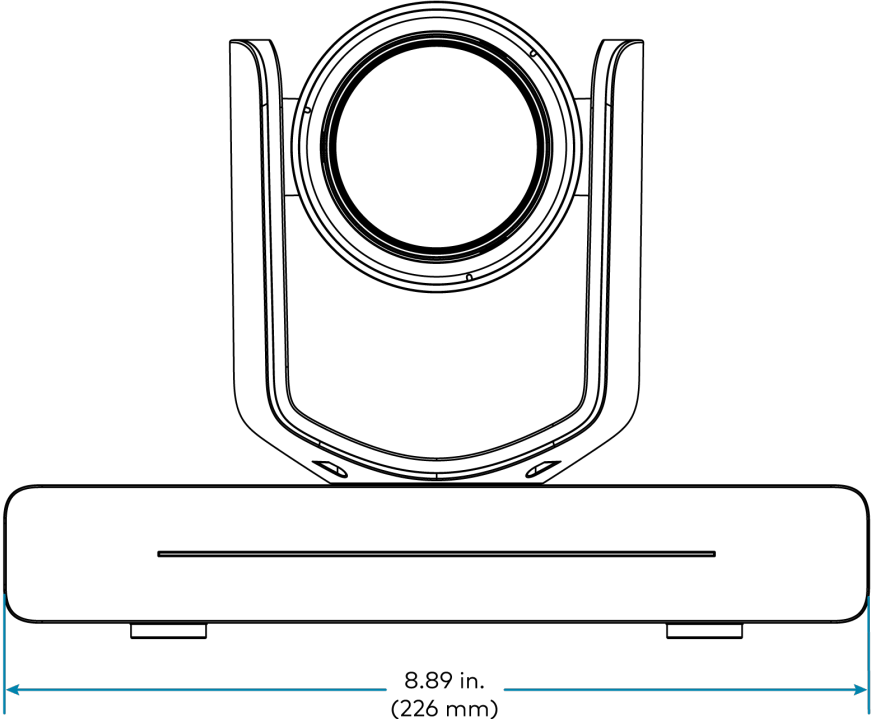

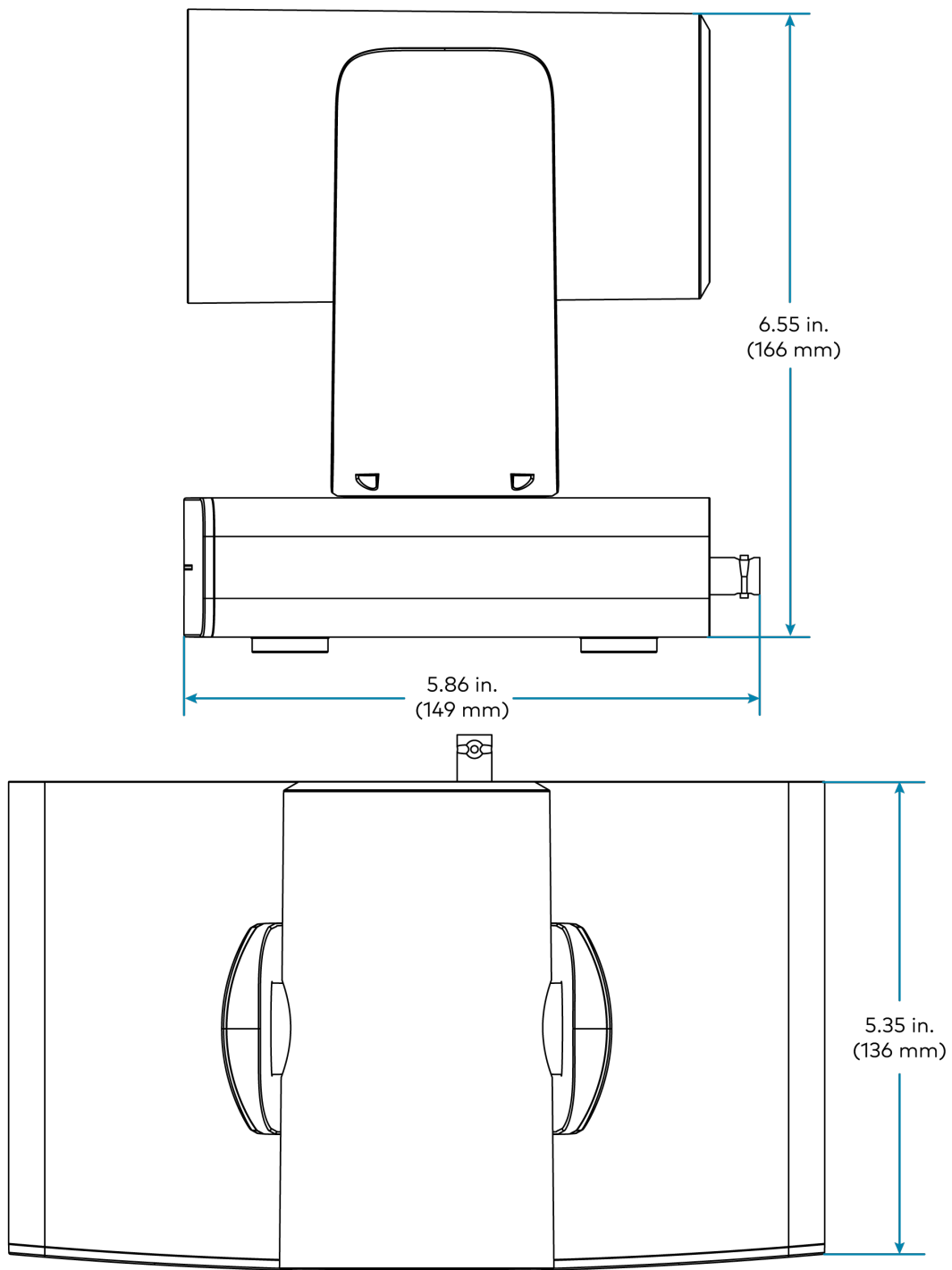

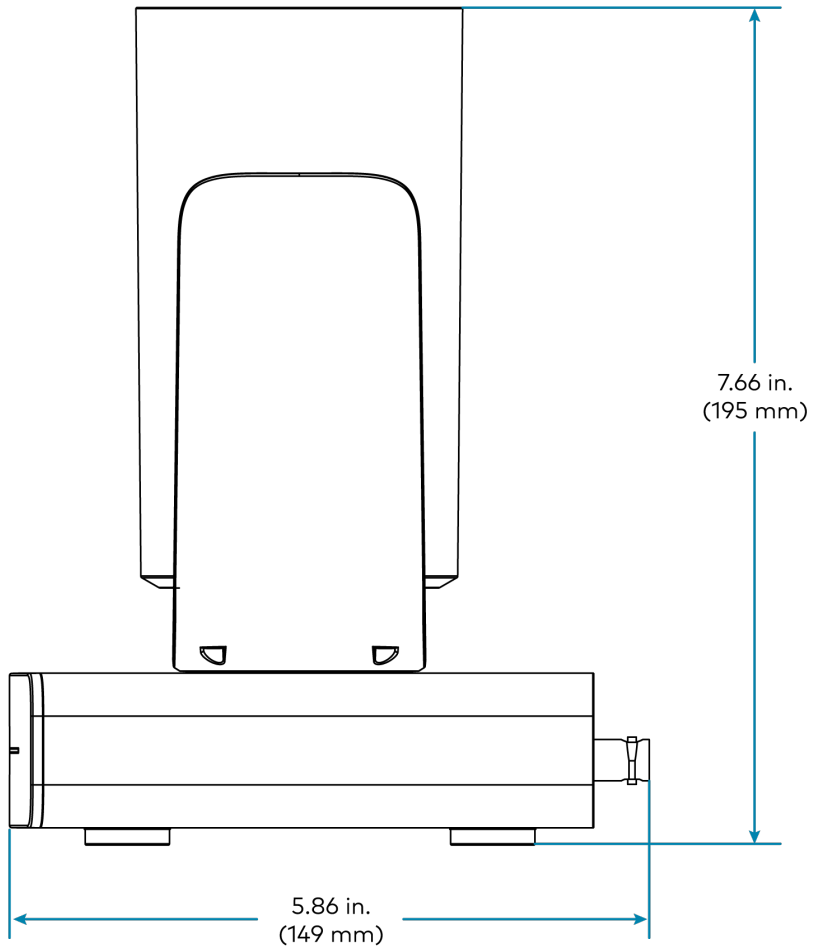

IV-CAM-P20 Specifications

Product specifications for the IV-CAM-P20 are provided below.

Specifications

Optics and Processing

Image Sensor	1/2.8 Sony® CMOS Sensor
Optical Zoom	20x
Focal Length	F=5.2–94 mm
Field of View	Horizontal: 56.45°
Shutter Speed	1/50-1/10,000 sec
Iris	F1.5-F3.0
Minimum Illumination	2 lux
Pan/Tilt Angle	Pan: -130° – 130°, Tilt: -30° – 90°
Pan/Tilt Speed	Pan: 0.2° – 90°/s, Tilt: 0.2° – 70°/s
Presets	Up to 256 configurable presets
White Balance	Auto, Indoor, One Push, Manual
Exposure	Auto, Manual, Shutter Priority, Iris Priority, Brightness Priority
Signal to Noise Ratio	≥50dB

Video

Video Outputs	3G-SDI, HDMI®, USB, NDI® HX2, ONVIF, RTSP, UVC
Signal Formats	SDI or HDMI: 1080p60/59.94/50/30/ 29.94/25, 720p60/59.94/50; USB (NV12 and MJPEG): 1080p30/25, 720p30/25, 360p30

Communications

Ethernet	RJ-45, 100Mbps
Serial	RS-232, RS-485
Control Protocol	VISCA/TCP, VISCA/UDP, PELCO-D, PELCO-P, ONVIF

Management Client

Software	Crestron 1 Beyond Camera Manager 2 (Windows® OS computer required)
-----------------	--

Connectors

COM	(1) 5-pin 3.5 mm detachable terminal block; Bidirectional RS-232/485 port
PoE	(1) 8-pin RJ-45 connector, female
3G-SDI OUT	(1) BNC connector, female; 3G-SDI digital video output
HDMI OUT	(1) HDMI Type A connector; HDMI digital video output
USB	(1) USB Type B connector, female; USB 3.0 device port for video and control; USB 2.0 device port for video (MJPEG only) and control
12VDC 2.5A	(1) 3.3 mm DC power connector; 12VDC power input; PW-1225DU power pack sold separately

Controls and Indicators

Status Bar	(1) Multisegment tricolor LED bargraph; Half green LED bargraph indicates live camera feed; Full amber LED bargraph indicates firmware upgrade; Half red LED bargraph indicates Privacy Mode
RESET	(1) Recessed push button for hardware reset

Power

Power Source Options	Ethernet (PoE), Power Pack (PW-1225DU)
Power over Ethernet	IEEE 802.3af Class 3 Powered Device
Power over Ethernet Rating	15.4 W

NOTE: To comply with the European Directive (CE), shielded CAT5e cable must be used as a minimum for PoE power.

Power Pack (sold separately)	12VDC, 2.5A, 50/60 Hz
-------------------------------------	-----------------------

Environmental

Temperature	32° to 104°F (0° to 40°C)
Humidity	10% to 90% RH (noncondensing)

Construction

Mounting Options [IV-CAMA-UMB](#) 1 Beyond Universal Mounting Bracket (included),
[IVA-WMT-BRKT-1B](#) 1 Beyond Wall Mount Bracket (sold separately),
[IVA-CMT-BRKTJ-1B](#) 1 Beyond J-Mount Bracket (sold separately)

Mounting Thread 1/4 in. threaded mount hole

Dimensions

Height 6.51 in. (165 mm)

Width 8.90 in. (226 mm)

Depth 5.86 in. (149 mm)

Weight

4.12 lb (1.87 kg)

Compliance

Regulatory Model: M202306003

FCC Part 15 Class B, IC Class B, CE, Intertek® Listed for US and Canada

Dimension Drawings

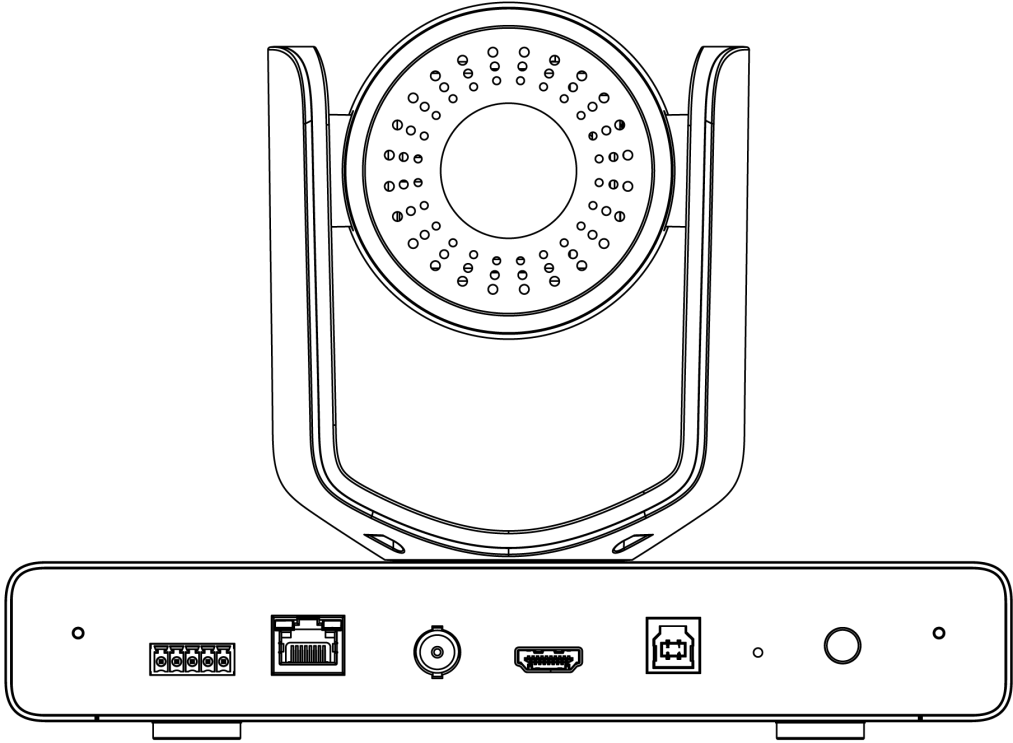
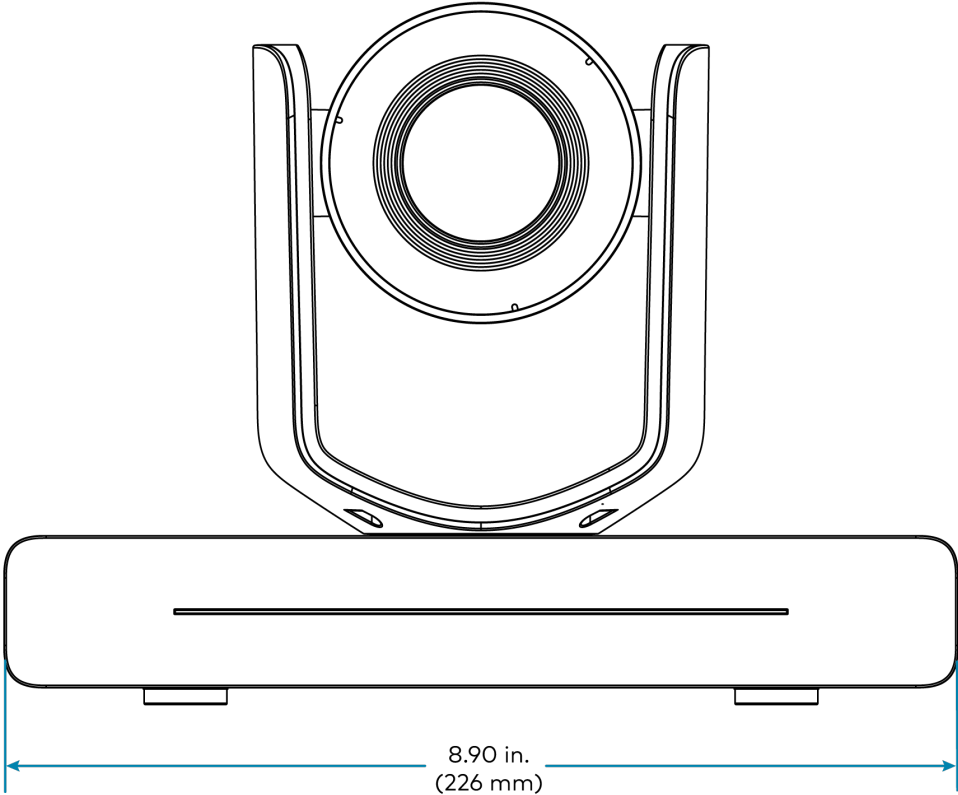

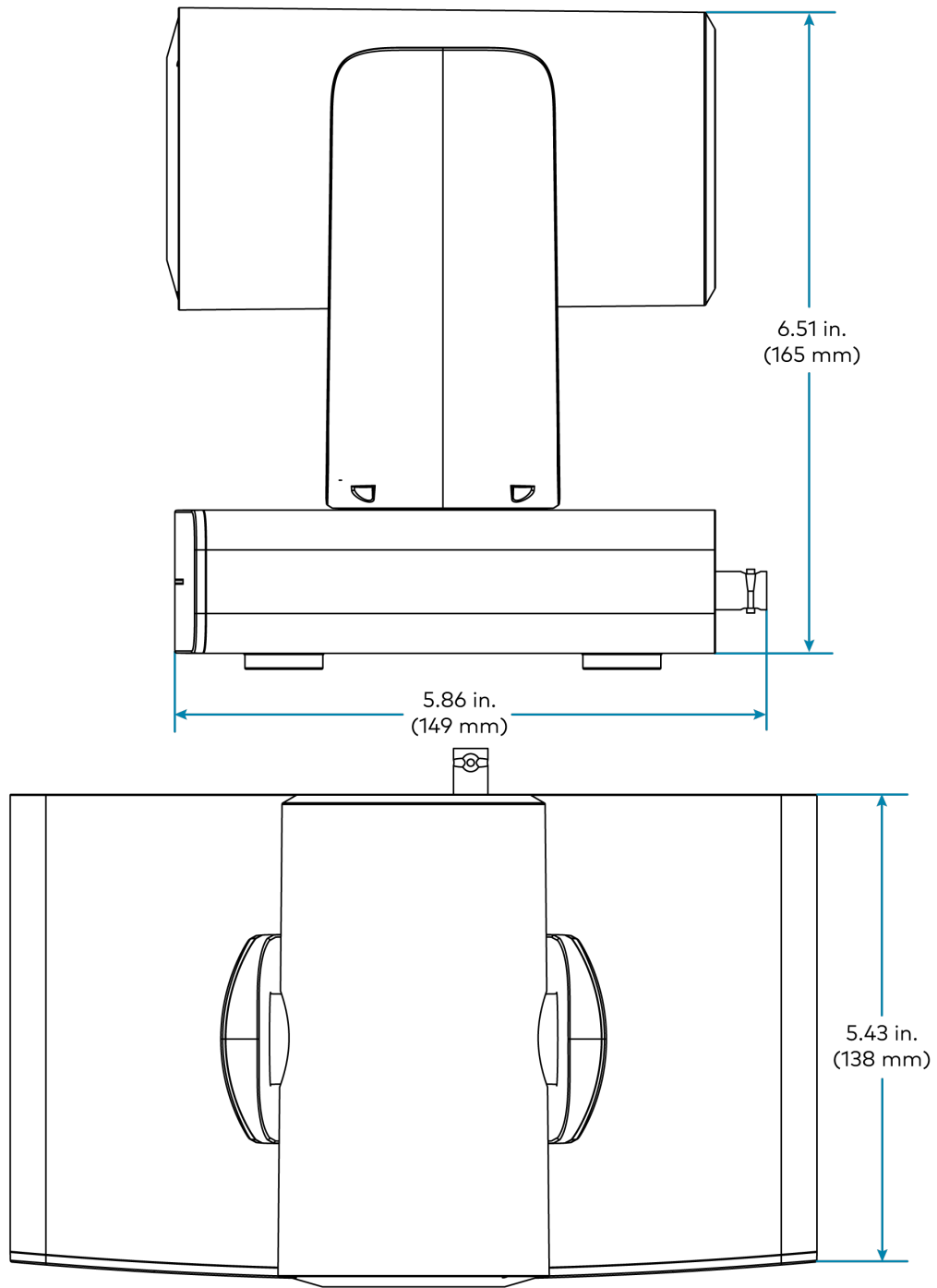

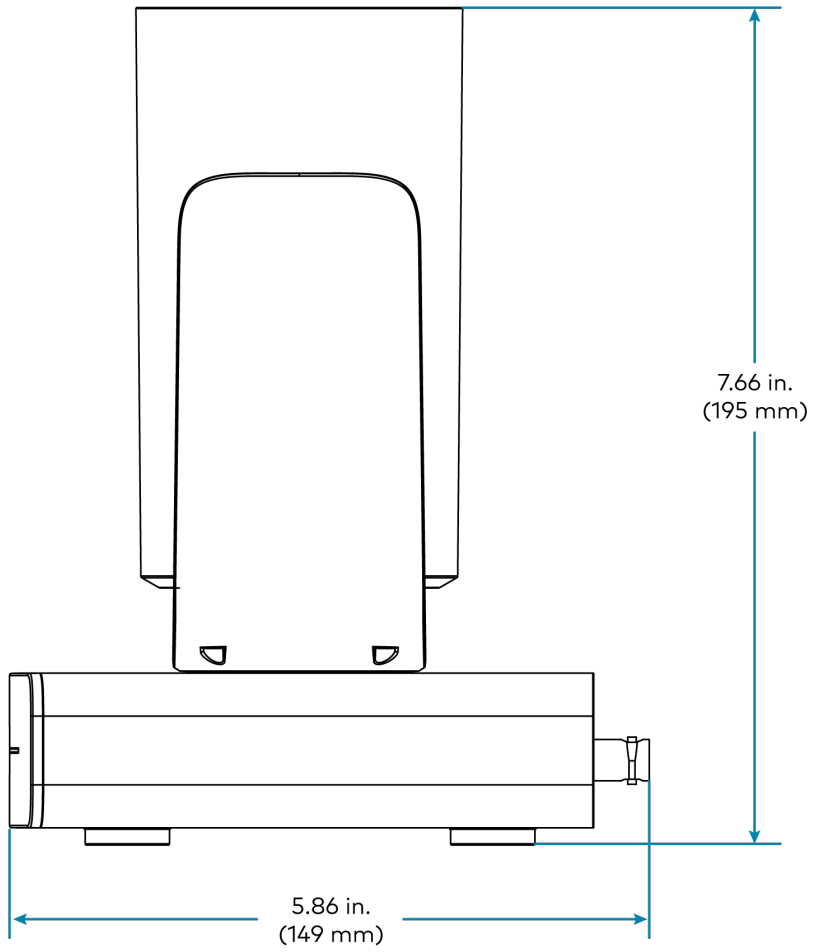

IV-CAM-I12 Specifications

Product specifications for the IV-CAM-I20 are provided below.

Specifications

Optics

Image Sensor	1/2.8 Sony® CMOS Sensor
Optical Zoom	12x
Focal Length	F=4.1–49.2 mm
Field of View (PTZ)	Horizontal: 67.68°
Field of View (Reference)	Horizontal: 104° (changes based on camera mode)
Shutter Speed	1/50-1/10,000 sec
Iris	F1.8-F2.68
Minimum Illumination	2 lux
Pan/Tilt Angle	Pan: -130° – 130°, Tilt: -30° – 90°
Pan/Tilt Speed	Pan: 0.2° – 90°/s, Tilt: 0.2° – 70°/s
White Balance	Auto, Indoor, One Push, Manual
Exposure	Auto, Manual, Shutter Priority, Iris Priority, Brightness Priority
Signal to Noise Ratio	≥50dB

Camera Processing

Intelligent Video Functions	Group Framing, Presenter Tracking, Intelligent Switching
Recommended Range (Group Framing)	5–25 ft
Recommended Range (Presenter Tracking)	15–25 ft
Presets	Up to 256 configurable presets

Video

Video Outputs	3G-SDI, HDMI®, USB, ONVIF, RTSP, UVC
Signal Formats	SDI or HDMI: 1080p60/59.94/50/30/ 29.94/25, 720p60/59.94/50; USB (NV12 and MJPEG): 1080p30/25, 720p30/25, 360p30

Communications

Ethernet	RJ-45, 100Mbps
Serial	RS-232, RS-485
Control Protocol	VISCA/TCP, VISCA/UDP, PELCO-D, PELCO-P, ONVIF

IR Receiver IR Camera Remote ([IV-CAMA-REMOTE](#))

Management Client

Software Crestron 1 Beyond Camera Manager 2 (Windows® OS computer required)

Connectors

COM (1) 5-pin 3.5 mm detachable terminal block;
Bidirectional RS-232/485 port

PoE (1) 8-pin RJ-45 connector, female

3G-SDI OUT (1) BNC connector, female;
3G-SDI digital video output

HDMI OUT (1) HDMI Type A connector;
HDMI digital video output

USB (1) USB Type B connector, female;
USB 3.0 device port for video and control;
USB 2.0 device port for video (MJPEG only) and control

12VDC 2.5A (1) 3.3 mm DC power connector;
12VDC power input;
[PW-1225DU](#) power pack sold separately

Controls and Indicators

Status Bar (1) Multisegment tricolor LED bargraph;
Half green LED bargraph indicates live camera feed;
Full green LED bargraph indicates camera tracking;
Full amber LED bargraph indicates firmware upgrade;
Half red LED bargraph indicates Privacy Mode

RESET (1) Recessed push button for hardware reset

Power

Power Source Options Ethernet (PoE), Power Pack ([PW-1225DU](#))

Power over Ethernet IEEE 802.3af Class 3 Powered Device

Power over Ethernet Rating 15.4 W

NOTE: To comply with the European Directive (CE), shielded CAT5e cable must be used as a minimum for PoE power.

Power Pack (sold separately) 12VDC, 2.5A, 50/60 Hz

Environmental

Temperature 32° to 104°F (0° to 40°C)

Humidity 10% to 90% RH (noncondensing)

Construction

Mounting Options	IV-CAMA-UMB 1 Beyond Universal Mounting Bracket (sold separately), IVA-WMT-BRKT-1B 1 Beyond Wall Mount Bracket (sold separately), IVA-CMT-BRKTJ-1B 1 Beyond J-Mount Bracket (sold separately)
Mounting Thread	1/4 in. threaded mount hole

Dimensions

Height	6.55 in. (166 mm)
Width	8.89 in. (226 mm)
Depth	5.86 in. (149 mm)

Weight

4.11 lb (1.86 kg)

Compliance

Regulatory Model: M202306003

FCC Part 15 Class B, IC Class B, CE, Intertek® Listed for US and Canada

Dimension Drawings

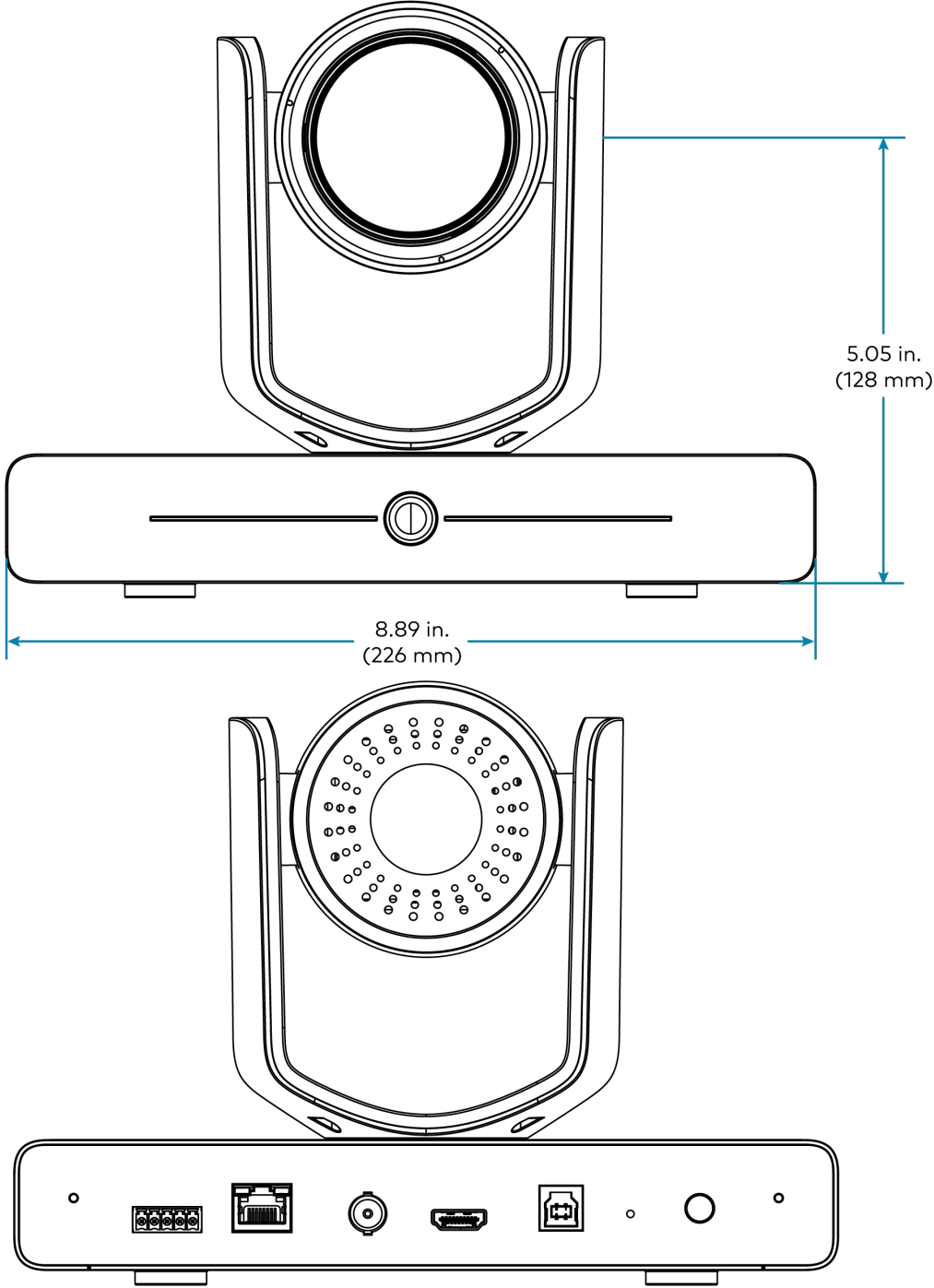

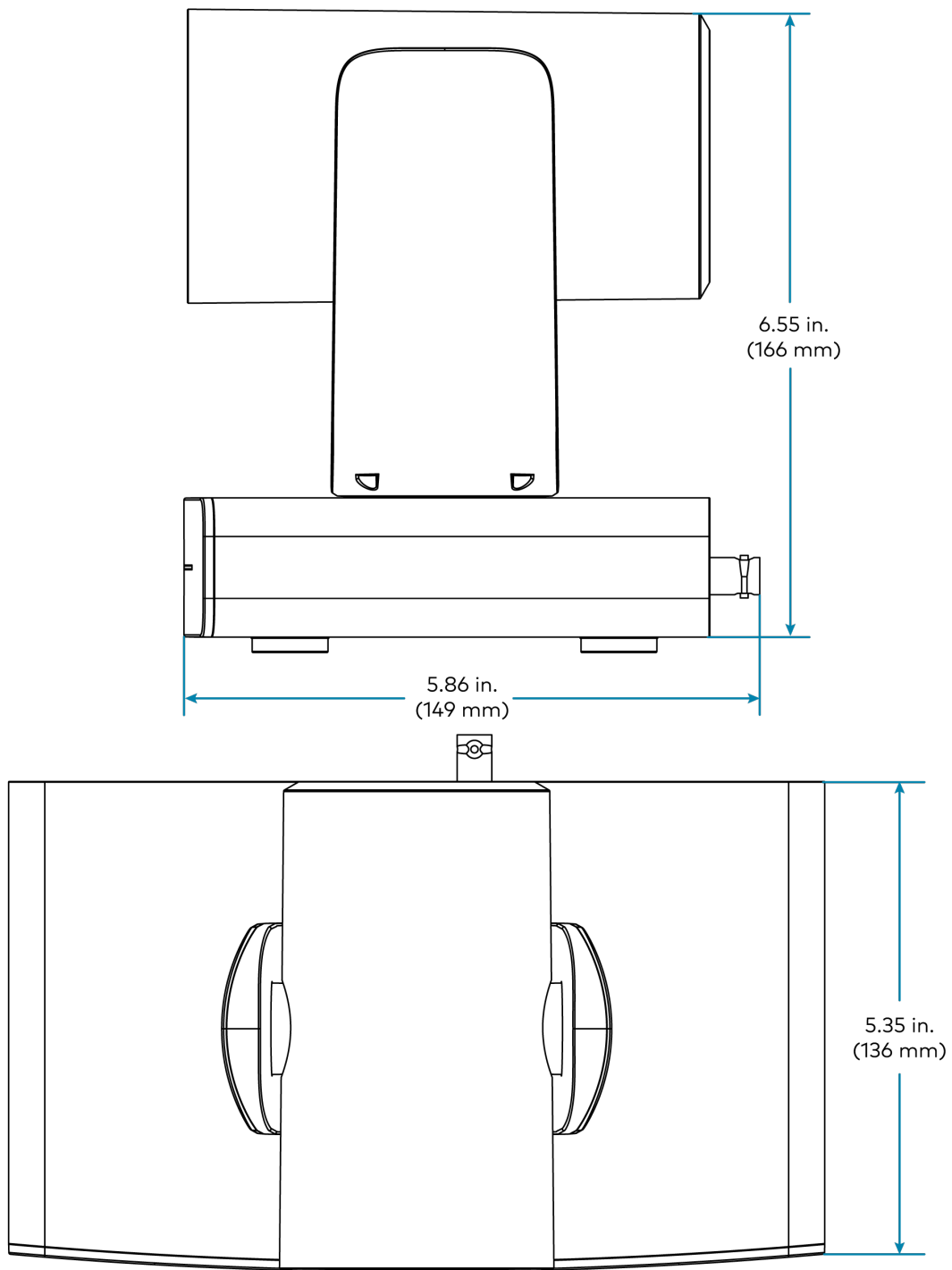

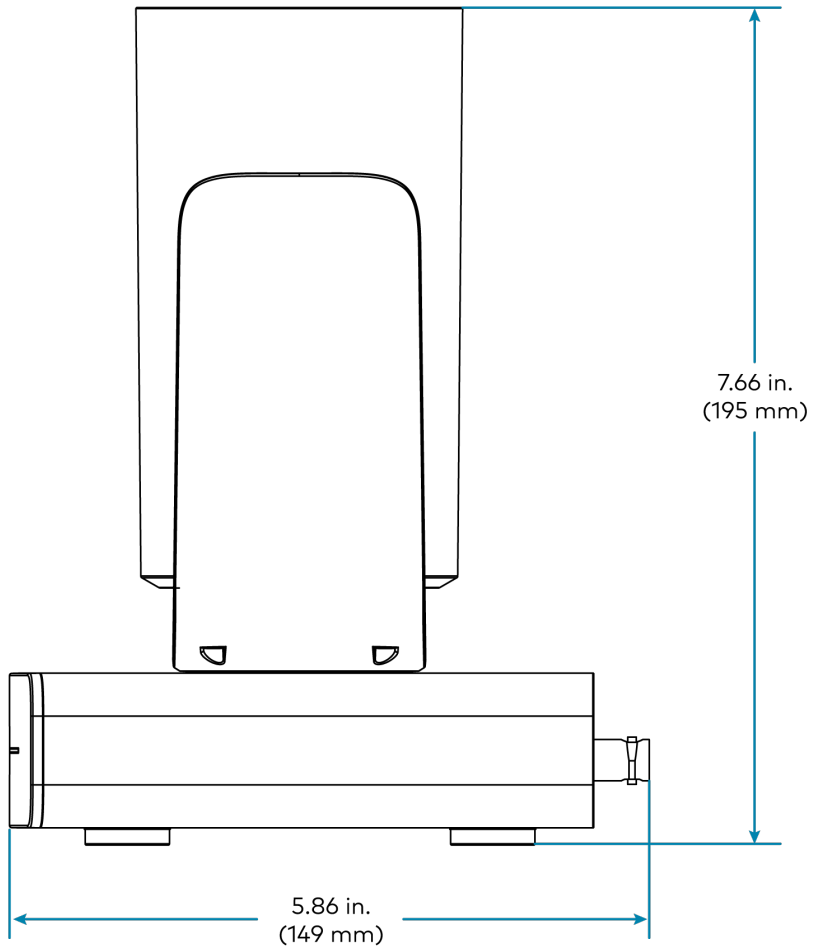

IV-CAM-I20 Specifications

Product specifications for the IV-CAM-I20 are provided below.

Specifications

Optics

Image Sensor	1/2.8 Sony® CMOS Sensor
Optical Zoom	20x
Focal Length	F=5.2–94 mm
Field of View (PTZ)	Horizontal: 56.45°
Field of View (Reference)	Horizontal: 104° (changes based on camera mode)
Shutter Speed	1/50-1/10,000 sec
Iris	F1.5-F3.0
Minimum Illumination	2 lux
Pan/Tilt Angle	Pan: -130° – 130°, Tilt: -30° – 90°
Pan/Tilt Speed	Pan: 0.2° – 90°/s, Tilt: 0.2° – 70°/s
White Balance	Auto, Indoor, One Push, Manual
Exposure	Auto, Manual, Shutter Priority, Iris Priority, Brightness Priority
Signal to Noise Ratio	≥50dB

Camera Processing

Intelligent Video Functions	Presenter Tracking, Group Tracking, Preset Zones
Recommended Range	15–50 ft
Presets	Up to 256 configurable presets

Video

Video Outputs	3G-SDI, HDMI®, USB, NDI® HX2, ONVIF, RTSP, UVC
Signal Formats	SDI or HDMI: 1080p60/59.94/50/30/ 29.94/25, 720p60/59.94/50; USB (NV12 and MJPEG): 1080p30/25, 720p30/25, 360p30

Communications

Ethernet	RJ-45, 100Mbps
Serial	RS-232, RS-485
Control Protocol	VISCA/TCP, VISCA/UDP, PELCO-D, PELCO-P, ONVIF

Management Client

Software	Crestron 1 Beyond Camera Manager 2 (Windows® OS computer required)
-----------------	--

Connectors

COM	(1) 5-pin 3.5 mm detachable terminal block; Bidirectional RS-232/485 port
PoE	(1) 8-pin RJ-45 connector, female
3G-SDI OUT	(1) BNC connector, female; 3G-SDI digital video output
HDMI OUT	(1) HDMI Type A connector; HDMI digital video output
USB	(1) USB Type B connector, female; USB 3.0 device port for video and control; USB 2.0 device port for video (MJPEG only) and control
12VDC 2.5A	(1) 3.3 mm DC power connector; 12VDC power input; PW-1225DU power pack sold separately

Controls and Indicators

Status Bar	(1) Multisegment tricolor LED bargraph; Half green LED bargraph indicates live camera feed; Full green LED bargraph indicates camera tracking; Full amber LED bargraph indicates firmware upgrade; Half red LED bargraph indicates Privacy Mode
RESET	(1) Recessed push button for hardware reset

Power

Power Source Options	Ethernet (PoE), Power Pack (PW-1225DU)
Power over Ethernet	IEEE 802.3af Class 3 Powered Device
Power over Ethernet Rating	15.4 W

NOTE: To comply with the European Directive (CE), shielded CAT5e cable must be used as a minimum for PoE power.

Power Pack (sold separately)	12VDC, 2.5A, 50/60 Hz
-------------------------------------	-----------------------

Environmental

Temperature	32° to 104°F (0° to 40°C)
Humidity	10% to 90% RH (noncondensing)

Construction

Mounting Options [IVA-WMT-BRKT-1B](#) 1 Beyond Wall Mount Bracket (included),
[IVA-CMT-BRKTJ-1B](#) 1 Beyond J-Mount Bracket (sold separately),
[IVA-CAMA-UMB](#) 1 Beyond Universal Mounting Bracket (sold separately)

Mounting Thread 1/4 in. threaded mount hole

Dimensions

Height 6.51 in. (165 mm)

Width 8.90 in. (226 mm)

Depth 5.86 in. (149 mm)

Weight

4.11 lb (1.86 kg)

Compliance

Regulatory Model: M202306003

FCC Part 15 Class B, IC Class B, CE, Intertek® Listed for US and Canada

Dimension Drawings

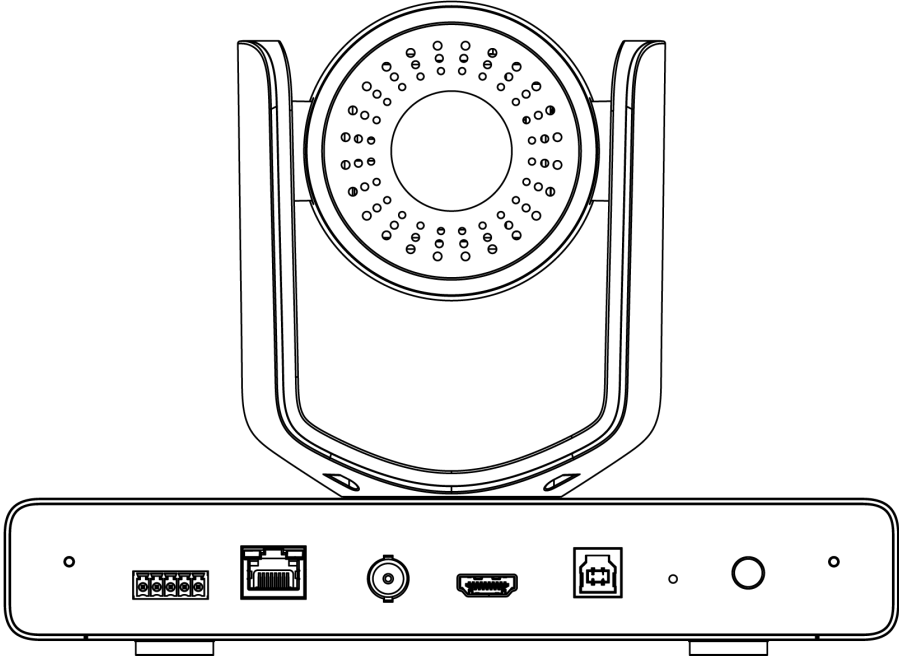
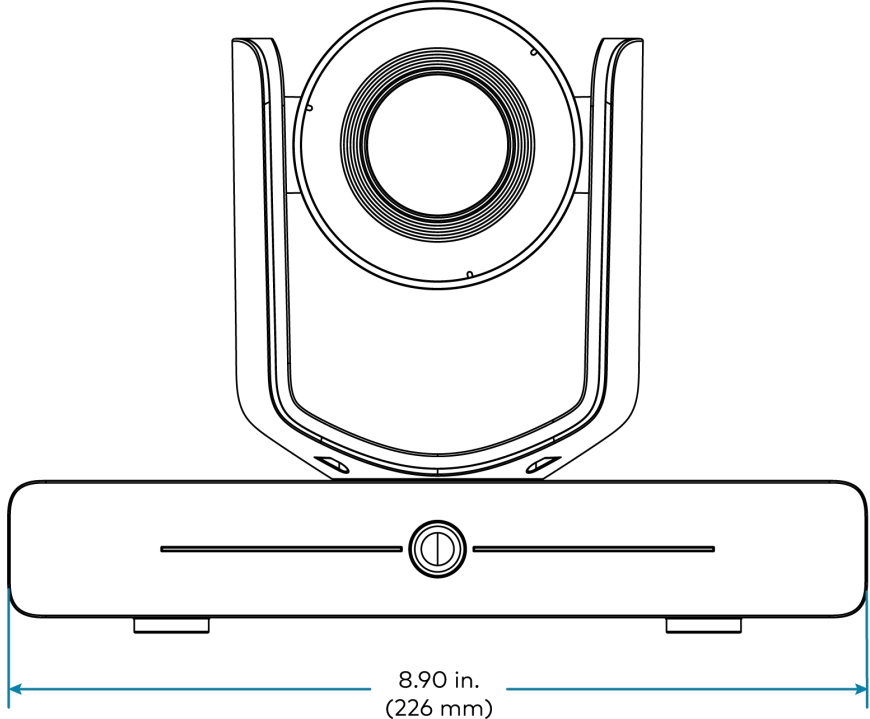

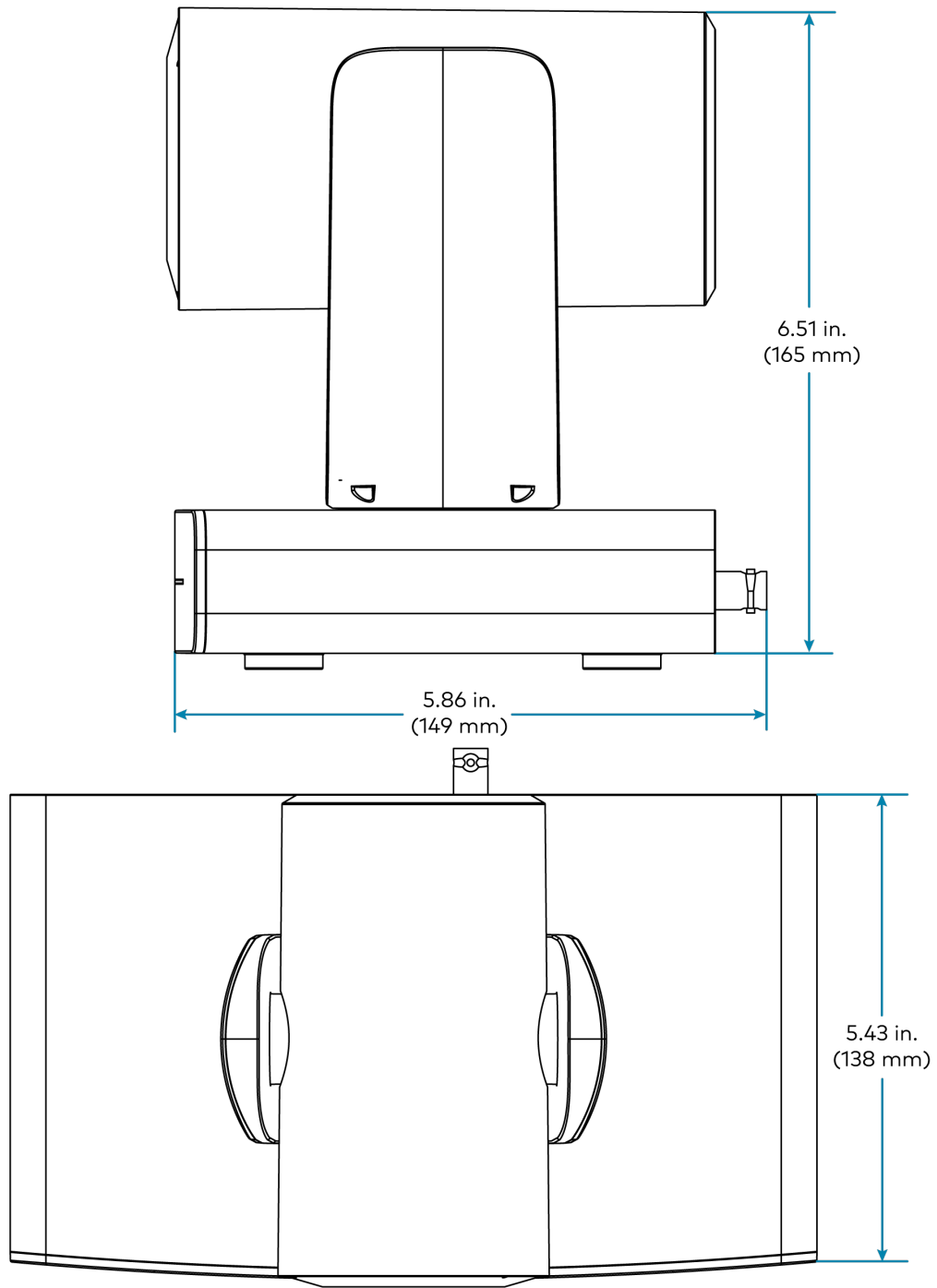

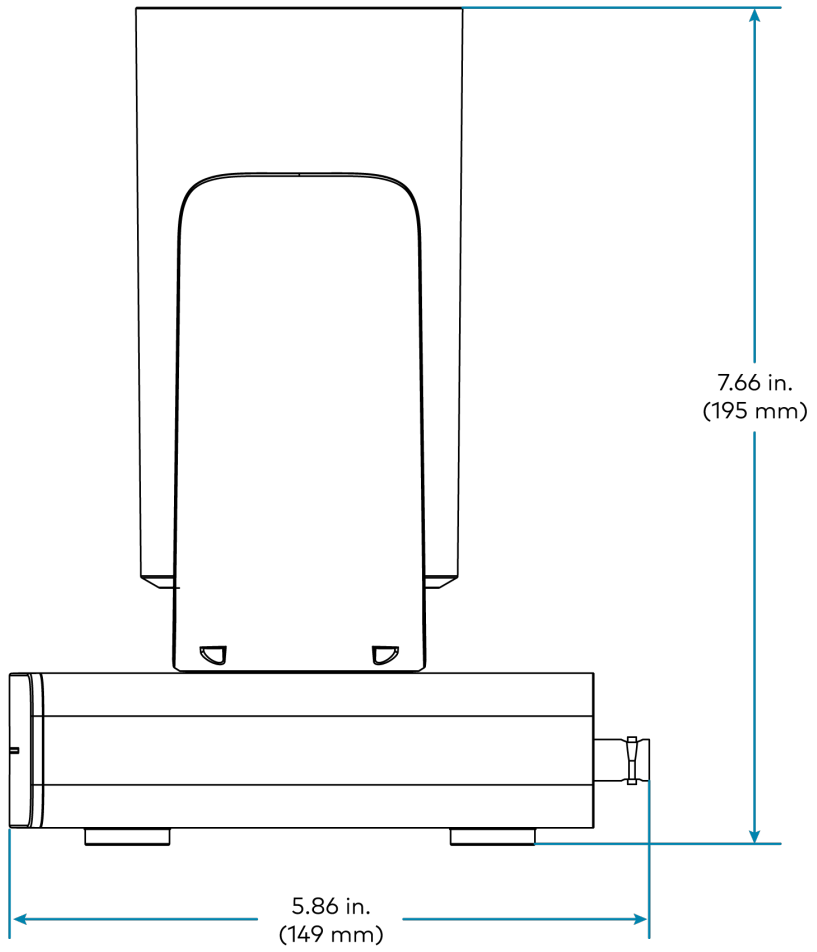

IV-CAM-I12D-B Specifications

Product specifications for the IV-CAM-I12D-B are provided below.

Specifications

Optics

Image Sensor	1/2.8 4K Sony® CMOS Sensors
Optical Zoom	12x
Focal Length	F=34–40.3 mm
Field of View (PTZ)	Horizontal: 80.5°
Field of View (Reference)	Horizontal: 110°
Shutter Speed	1/60-1/10,000 sec
Iris	F1.8-F3.6
Minimum Illumination	2 lux
Pan/Tilt Angle	Pan: -130° – 130°, Tilt: -30° – 90°
Pan/Tilt Speed	Pan: 0.2° – 90°/s, Tilt: 0.2° – 70°/s
White Balance	Auto, One Push, Manual, Static
Exposure	Auto, Manual, Shutter Priority, Iris Priority, Brightness Priority
Signal to Noise Ratio	≥50dB

Camera Processing

Intelligent Video Functions	Speaker Tracking, Group Framing, Conversation Mode, Intelligent Switching
Recommended Range	5–25 ft
Presets	Up to 512 configurable presets

Video

Video Outputs	HDMI®, USB, RTSP
Signal Formats	HDMI: 4K30/25, 1080p59.94/50/30/ 29.94/25, 720p59.94/50; USB (NV12 and MJPEG): 4K30/25, 1440p30, 1080p30/25, 720p30/25, 360p30

Communications

Ethernet	RJ-45, 1000Mbps
Serial	RS-232, RS-485
Control Protocol	VISCA Passthrough, VISCA over IP, PELCO-D, PELCO-P, UVC, AES67 (input)
AUDIO REF	(1) 3-pin 3.5 mm detachable terminal block; Balanced audio input for analog connection
COM	(1) 5-pin 3.5 mm detachable terminal block; Bidirectional RS-232/485 port
USB2 TO DEVICE	(1) USB Type A connector, female (not used)
HDMI OUT	(1) HDMI Type A connector; HDMI digital video output
USB3 TO HOST	(1) USB Type C connector, female; USB 3.0/2.0 device port for video and control
24VDC 2.5A	(1) 5.5 mm DC power connector; 24VDC power input

Management Client

Software	Crestron 1 Beyond Camera Manager 2 (Windows® OS computer required)
-----------------	--

Controls and Indicators

Status Bar	(1) Multisegment tricolor LED bargraph; Half green LED bargraph indicates live camera feed; Full green LED bargraph indicates camera tracking; Full amber LED bargraph indicates firmware upgrade; Half red LED bargraph indicates Privacy Mode
RESET	(1) Recessed push button for hardware reset

Power

Power Source Options	Power Pack (PW-2420RU)
Power Pack	24VDC, 2.5A, 50/60 Hz

Environmental

Temperature	32° to 104°F (0° to 40°C)
Humidity	10% to 90% RH (noncondensing)

Construction

Mounting Options	i12D Wall Mount Bracket (included)
Mounting Thread	1/4 in. threaded mount holes

Dimensions

Height	7.61 in. (193 mm)
Width	19.69 in. (500 mm)
Depth	6.10 in. (155 mm)

Weight

9.00 lb (4.08 kg)

Compliance

Regulatory Model: M202306003

FCC Part 15 Class B, IC Class B, CE, Intertek® Listed for US and Canada

Dimension Drawings

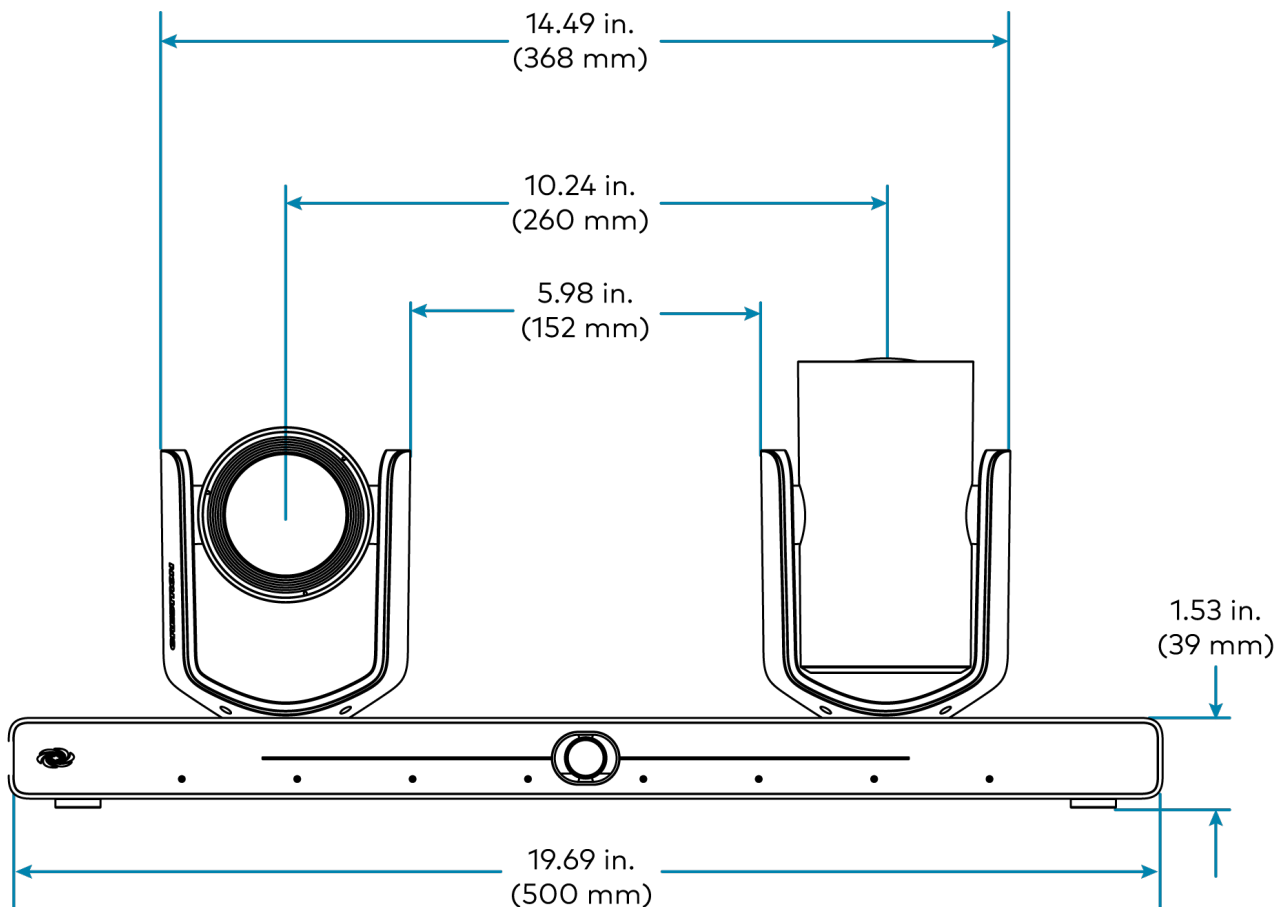

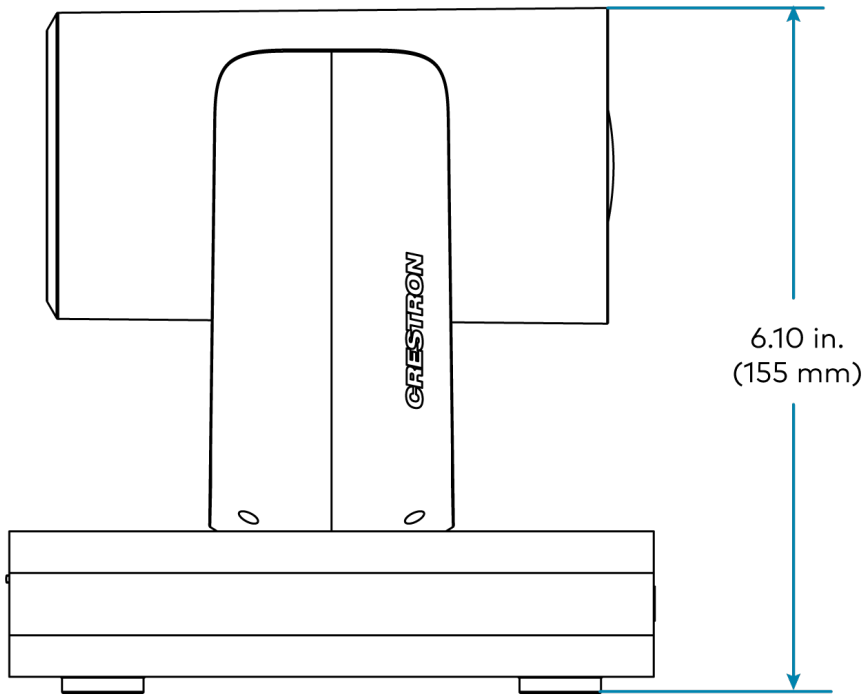
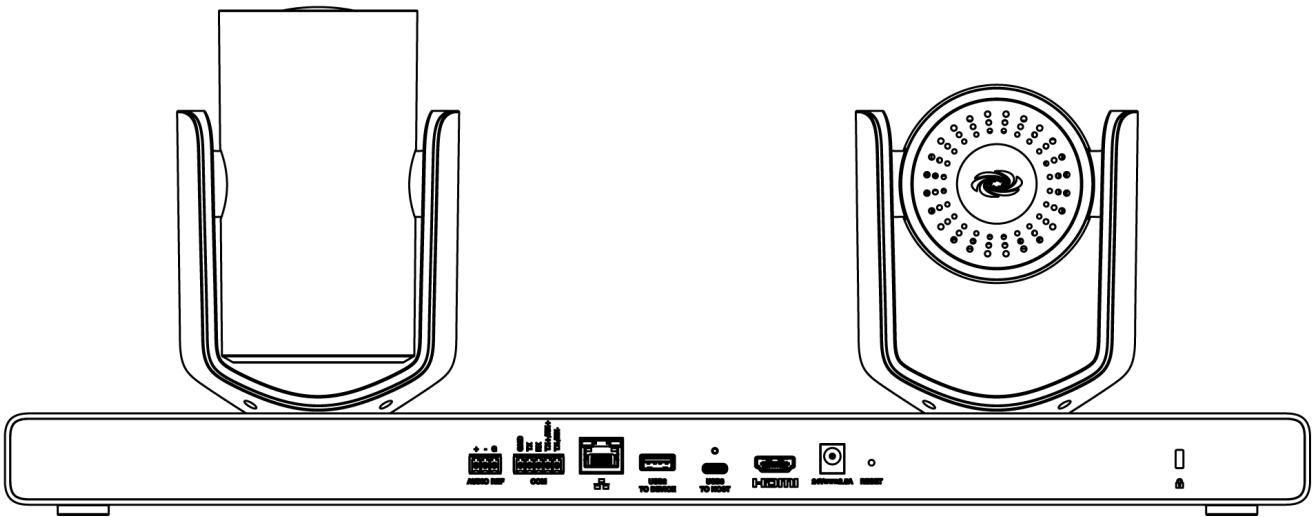

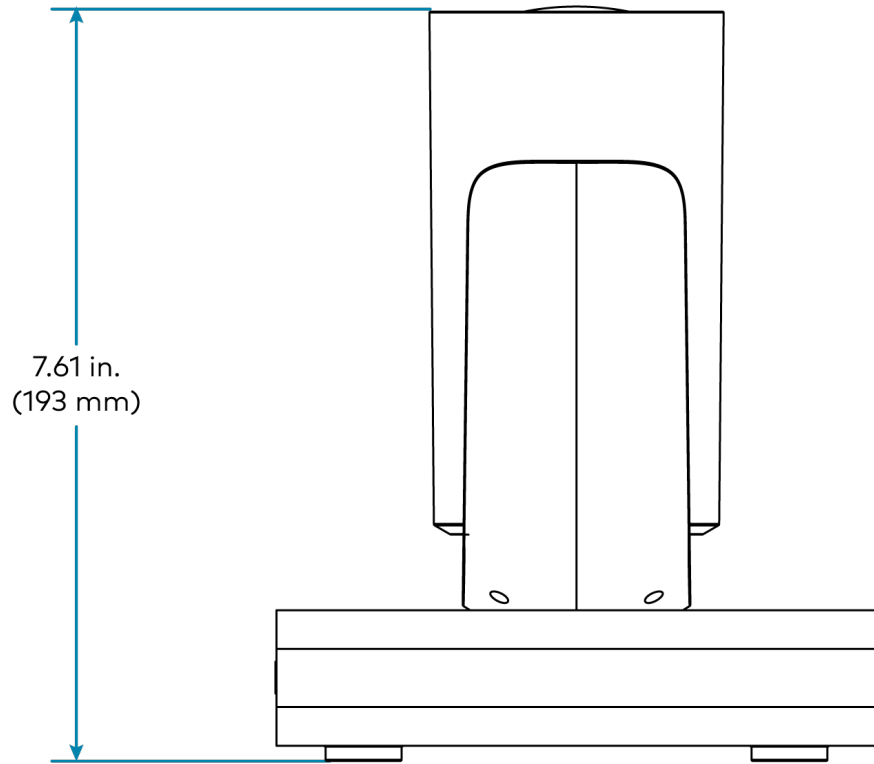
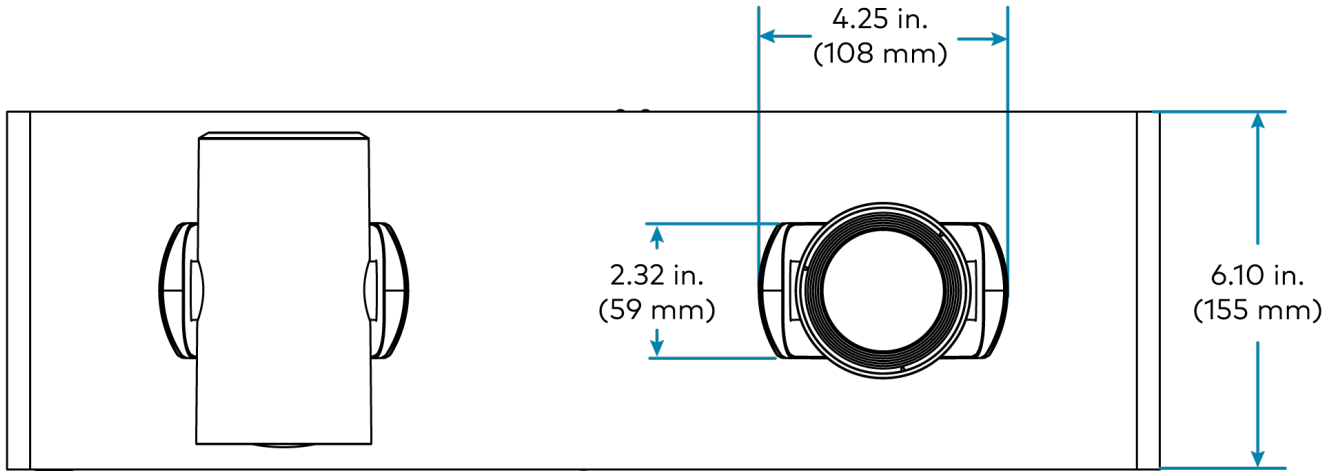

Camera Accessory Specifications

Refer to the following sections for more information on the specifications of the Crestron 1 Beyond camera accessories.

This section provides the following information:

- [IV-CAMA-UMB Specifications](#)
- [IVA-WMT-BRKT-1B Specifications](#)
- [IVA-CMT-BRKTJ-1B Specifications](#)
- [IV-CAMA-REMOTE Specifications](#)
- [PW-1225DU Specifications](#)

IV-CAMA-UMB Specifications

Product specifications for the IV-CAMA-UMB are provided below.

Specifications

Construction

Base Material	Die-cast aluminum
Cover Material	Plastic

Dimensions

Height	1.73 in. (44 mm)
Width	8.90 in. (226 mm)
Length	8.33 in. (212 mm)

Weight

1.47 lb (0.67 kg)

Dimension Drawings

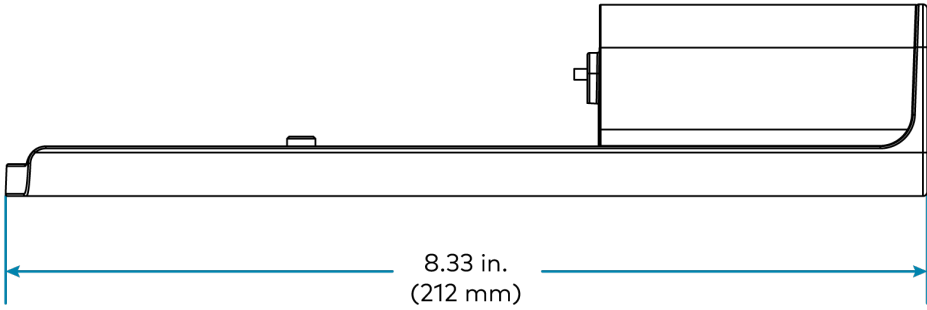
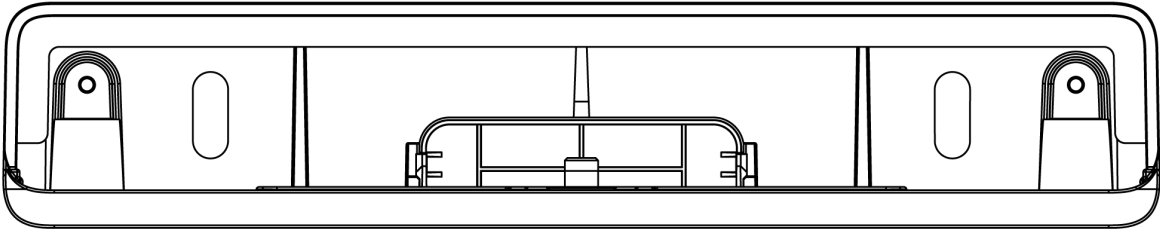
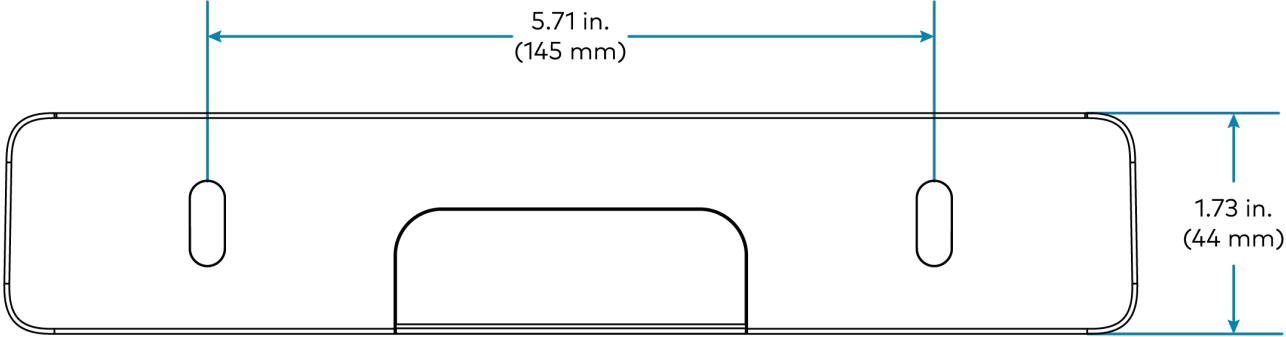

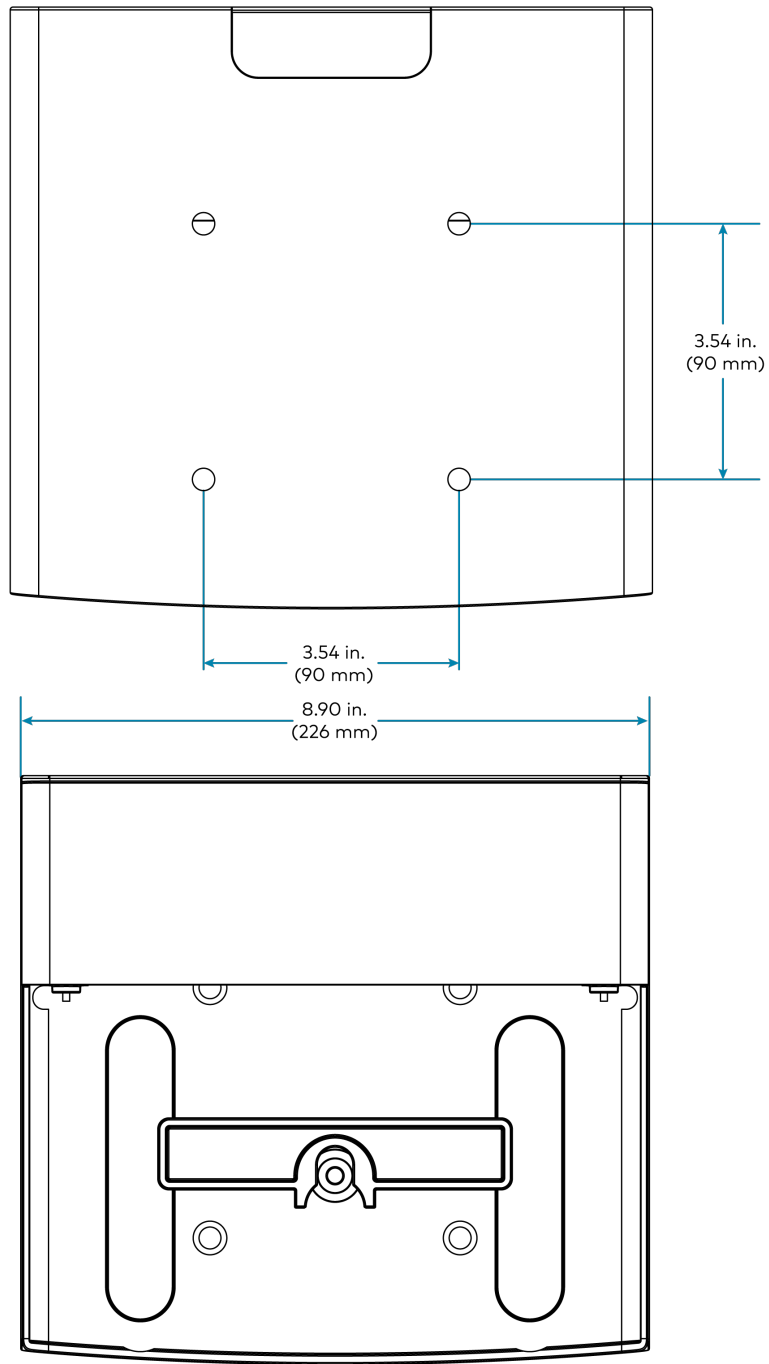

IVA-WMT-BRKT-1B Specifications

Product specifications for the IVA-WMT-BRKT-1B are provided below.

Specifications

Construction

Material Metal

Dimensions

Height 3.74 in. (95 mm)

Width 2.56 in. (65 mm)

Length 7.44 in. (189 mm)

Weight

0.50 lb (0.23 kg)

Dimension Drawings

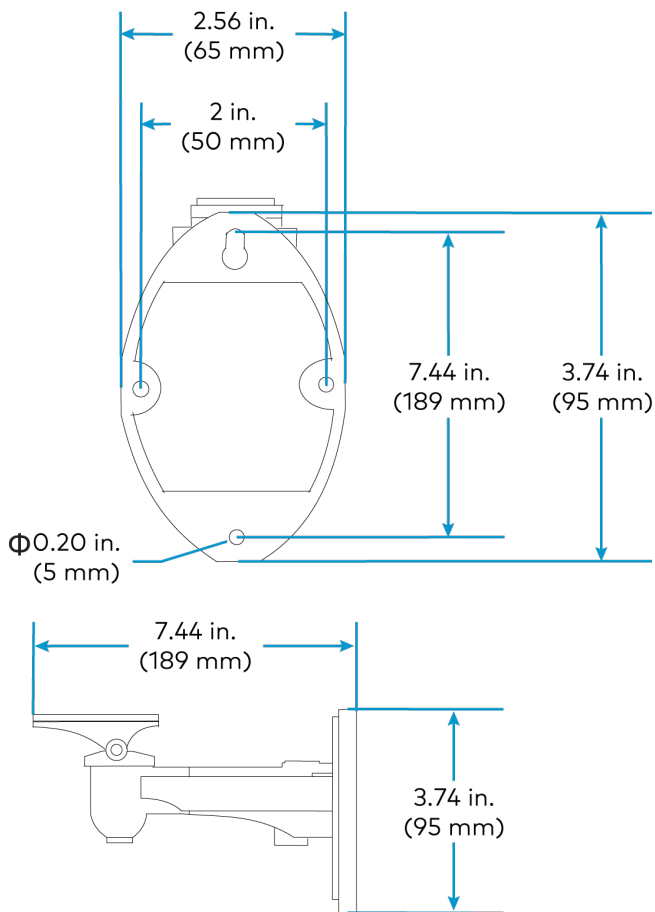

IVA-CMT-BRKTJ-1B Specifications

Product specifications for the IVA-CMT-BRKTJ-1B are provided below.

Specifications

Construction

Material Metal

Dimensions

Height to Camera Plate (adjustable) Minimum 22.5 in. (572 mm);
Maximum 38.5 in. (978 mm)

Height Top to Bottom (adjustable) Minimum 28.0 in. (711 mm);
Maximum 44.0 in. (1118 mm)

Width (bracket diameter) 5.12 in. (130 mm)

Depth 9.12 in. (232 mm)

Weight

1.74 lb (0.79 kg)

Dimension Drawings

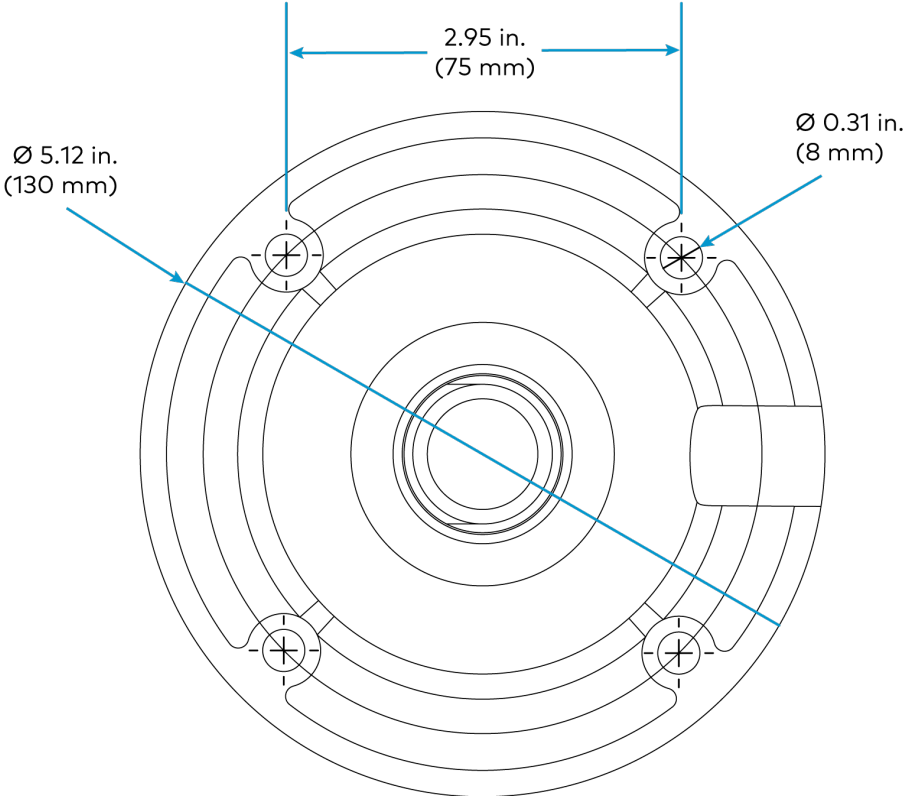

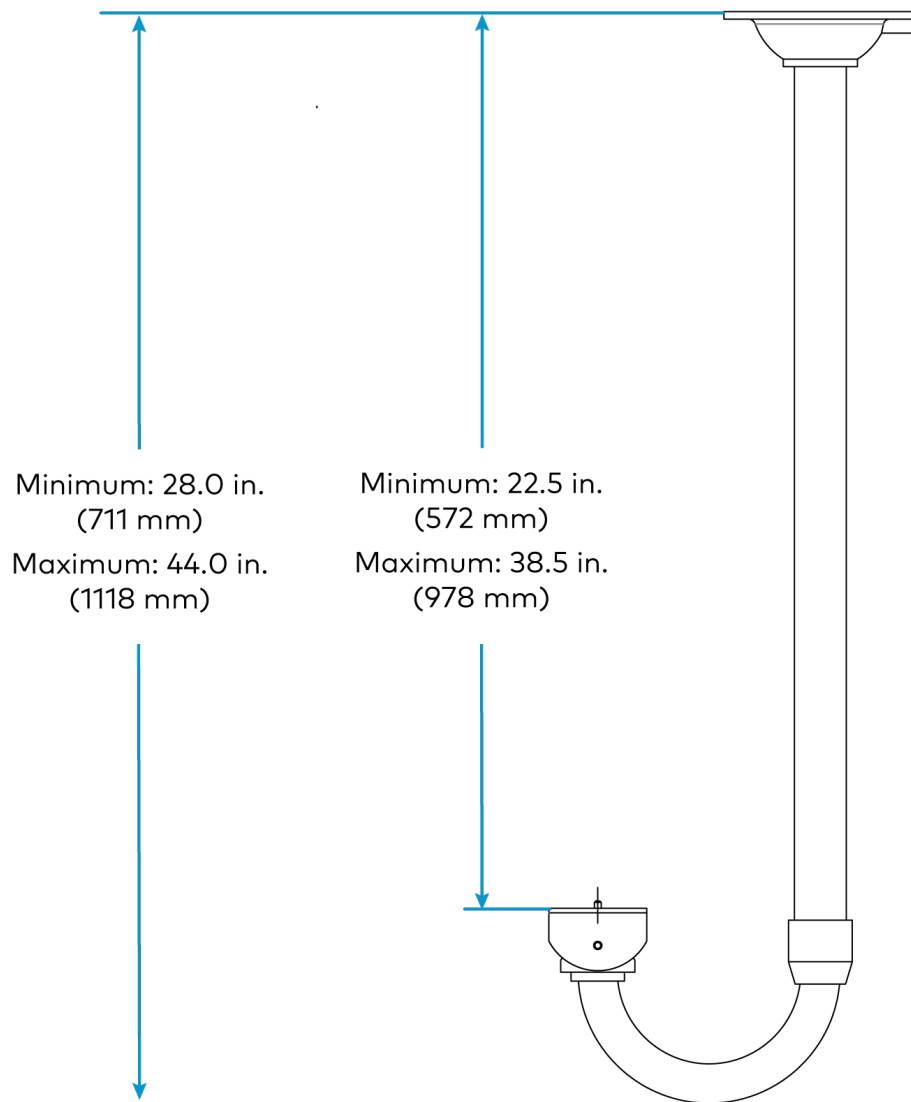

IV-CAMA-REMOTE Specifications

Product specifications for the IV-CAMA-REMOTE are provided below.

Specifications

Buttons

Power	(1) Push button with red power icon; Enables or disables Privacy Mode
Menu	(1) Push button with list icon; Opens On-Screen Display (OSD) menu
Zoom	(2) Push buttons with magnifying glass icons; Increases or decreases camera zoom
Navigation Pad	(1) 4-way directional navigation pad for left, right, up, and down; For camera pan and tilt, and navigating through the On-Screen Display (OSD) menu
Home	(1) Push button with home icon; Calls or sets Home Shot
Autofocus	(1) Push button with letter A text; Triggers Autofocus
Focus	(2) Push buttons with focus box icons; Increases or decreases camera focus
Function	(2) Push buttons with F1/F2 text; Enables or disables Tracking mode
Number Pad	(3) Push buttons with numbered text; Calls or sets camera presets

Power

Batteries	(2) AAA batteries required (not included)
------------------	---

Construction

Material	Plastic
-----------------	---------

Weight

0.07 lb (0.03 kg)

Compliance

Regulatory Model: M202306003

FCC Part 15 Class B, IC Class B, CE

PW-1225DU Specifications

Product specifications for the PW-1225DU are provided below.

Specifications

Output Rating

12VDC, 2.5A, regulated

Power Requirements

0.6A (maximum) @ 100-240VAC, 50/60 Hz

Connections

Line	(1) C8 2 pin main power input
Load	(1) 6 ft (1.83 m) attached cable with 5.5 x 3.3 mm DC power barrel connector

Environmental

Temperature	23° to 104°F (-5° to 40°C)
Humidity	5% to 90% RH (noncondensing)

Construction

Plastic, black, desktop

Weight

0.54 lb (0.24 kg)

Compliance

CE

Installation

This section provides the following information:

- [In The Box](#)
- [Mounting Requirements](#)
- [Install the Mounting Hardware](#)
- [Connect the Camera](#)
- [IV-CAM-I12D-B Installation](#)
- [Connect the IV-CAM-I12D-B Camera](#)

In The Box

The following items are included with Crestron 1 Beyond cameras.

IV-CAM-P12-B

Qty.	Description
1	IV-CAM-P12-B, Crestron 1 Beyond P12 Camera
Additional Items	
1	Connector, 5-Pin (2062506)
1	IV-CAMA-UMB-B, Universal Mount, Moon Gray (2062507)

IV-CAM-P12-W

Qty.	Description
1	IV-CAM-P12-W, Crestron 1 Beyond P12 Camera
Additional Items	
1	Connector, 5-Pin (2062506)
1	IV-CAMA-UMB-W, Universal Mount, Bright White (2062508)

IV-CAM-P20-B

Qty.	Description
1	IV-CAM-P20-B, Crestron 1 Beyond P20 Camera
Additional Items	
1	Connector, 5-Pin (2062506)
1	IV-CAMA-UMB-B, Universal Mount, Moon Gray (2062507)

IV-CAM-P20-W

Qty.	Description
1	IV-CAM-P20-W, Crestron 1 Beyond P20 Camera

Additional Items	
1	Connector, 5-Pin (2062506)
1	IV-CAMA-UMB-W, Universal Mount, Bright White (2062508)

IV-CAM-I12-B

Qty.	Description
1	IV-CAM-I12-B, Crestron 1 Beyond I12 Camera

Additional Items	
1	Connector, 5-Pin (2062506)
1	IV-CAMA-REMOTE, IR Remote
1	Cable, USB 3.0, B to A, 1.8 M (2062771)

IV-CAM-I20-B

Qty.	Description
1	IV-CAM-I20-B, Crestron 1 Beyond I20 Camera

Additional Items	
1	Connector, 5-Pin (2062506)
1	IVA-WMT-BRKT-1B-B, Wall Mount, Black (2062745)

IV-CAM-I20-W

Qty.	Description
1	IV-CAM-I20-W, Crestron 1 Beyond I20 Camera

Additional Items	
1	Connector, 5-Pin (2062506)
1	IVA-WMT-BRKT-1B, Wall Mount, White

IV-CAM-I12D-B

Qty.	Description
1	IV-CAM-I12D-B, Crestron 1 Beyond i12D Camera

Additional Items

1	Bracket, Wall Mount, Black (2066145)
1	Power Cord (2066146)
1	Power Adapter (2066147)
1	Cable, USB-C to USB-A (2066148)
1	IV-CAMA-REMOTE, IR Remote (2066149)
1	Connector, 5-Pin (2066150)
1	Connector, 3-Pin (2066151)
4	Screw, M6*40 (2066152)
3	Screw, 1/4-20UNC x 8 mm (2066153)
4	Drywall Anchor (2066154)

Mounting Requirements

Crestron 1 Beyond cameras must be mounted per the following guidelines for optimal camera performance. Ensure cameras are mounted in location that offers a clear view of their subjects.

CAUTION: To avoid damaging the camera:

- Do not remove any screws from the camera. There are no user-serviceable parts inside. If the camera is damaged or malfunctioning, contact Crestron's True Blue Support Team via phone, email, or chat as described at <https://www.crestron.com/Support>.
- Do not operate the camera beyond the specified temperature and humidity limits. Operating range of the camera is between 32° to 104°F (0° to 40°C). Ambient humidity should be less than 90% RH.
- Do not aim the camera lens at the sun or extremely bright lights. Doing so can cause damage to the image sensor.
- Do not move the camera head manually. Doing so can cause damage to the camera and inner gear systems. Do not carry the camera by the head; always handle the camera by the base.
- Do not expose the camera to rain, water, or high moisture.
- This camera is designed for indoor use only.

Intelligent Camera Mounting

Intelligent Crestron 1 Beyond cameras (IV-CAM-I12-B and IV-CAM-I20 Series cameras) have additional mounting requirements:

NOTE: The IV-CAM-I12D-B has unique mounting requirements. For more information on the mounting requirements for the IV-CAM-I12D-B, refer to [IV-CAM-I12D-B Installation on page 104](#).

- Intelligent cameras cannot be inverted.
- The fixed wide-angle camera lens must be able to view the entire subject area as it is used by the tracking algorithm for visual AI.
- Do not position the camera where the wide angle camera predominately covers the ceiling, as it results in suboptimal tracking performance. If the room has a slanted ceiling (such as an auditorium), the camera should be positioned at a 1° to 15° slant as well.

NOTE: Mounting the camera on a 1° to 15° slant is only available for [IVA-CMT-BRKTJ-1B series](#) and [IVA-WMT-BRKT-1B series](#) mounts. For more information about tilting cameras with mounting hardware, refer to [Install the Mounting Hardware on page 79](#).

- Mount the camera as close as possible to the central axis of the area where the subject will be tracked. This is typically the center of the back wall.

Mounting Measurements

Use the following table to determine the appropriate camera mounting distances and heights.

Camera Mounting Measurements

Camera & Mode	Distance From Subject	Height	Can be Inverted	Maximum Tilt Angle
IV-CAM-P12 Series	5–35 ft (1.5–10.7 m)	6–10 ft (1.8–3.1 m)	Yes	0°
IV-CAM-P20 Series	10–60 ft (3.1–18.3 m)	6–12 ft (1.8–3.7 m)	Yes	0°
IV-CAM-I12-B (Group Framing)	5–25 ft (1.5–7.6 m)	4–7 ft (1.8–2.1 m)	No	15°
IV-CAM-I12-B (Presenter Tracking)	10–25 ft (3.1–7.6 m)	6–8 ft (1.8–2.4 m)	No	15°
IV-CAM-I20 Series	15–50 ft (4.6–15.2 m)	6–10 ft (1.8–3.1 m)	No	15°

Stacked Camera Mounting Distance

When mounting cameras together, maintain a distance of at least 17 in. (432 mm) from the base of each camera. Refer to the following drawing for an example of stacked cameras mounted:

Stacked Camera Mounting

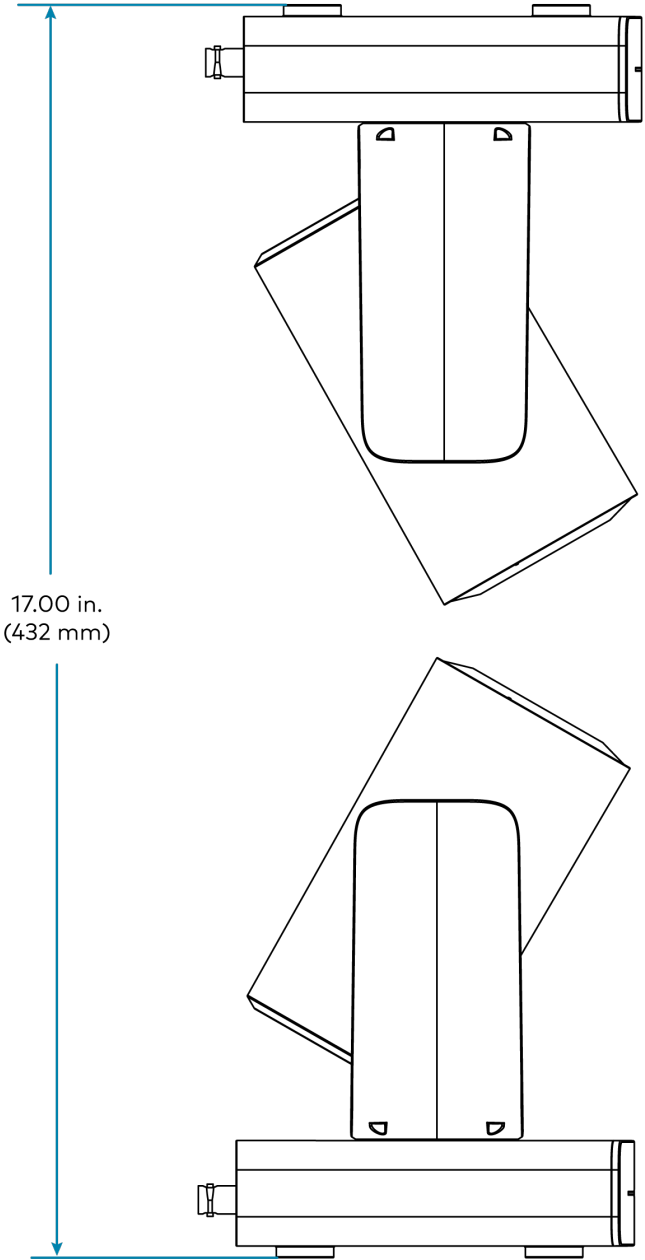

Install the Mounting Hardware

Crestron 1 Beyond cameras have multiple mounts available for installation depending on camera usage and room requirements.

This section provides the following information:

- [IV-CAMA-UMB Installation](#)
- [IVA-WMT-BRKT-1B Installation](#)
- [IVA-CMT-BRKTJ-1B Installation](#)

IV-CAMA-UMB Installation

The IV-CAMA-UMB Universal Mounting Bracket can be mounted to the wall as a camera shelf mount or it can be mounted onto the ceiling for inverted camera configurations.

NOTE: Camera inversion is only available for IV-CAM-P12 Series and IV-CAM-P20 cameras.

Refer to the following sections for information on mounting the IV-CAMA-UMB.

In the Box

Qty.	Description
1	IV-CAMA-UMB, Crestron 1 Beyond Universal Mounting Bracket
Additional Items	
4	Screw, 6.3 x 38 mm (2062877)
4	Drywall Anchor (2062876)
1	Screw, 1/4-20 x 3/8 in. (2062875)
2	Hand Screw, M2.5 x 12 mm (2062878)
1	Release Plate (2062879)
1	Installation Template Sheet (2062784)

IV-CAMA-UMB Wall Installation

Use the following procedure to install the IV-CAMA-UMB to the wall:

1. Choose a mounting location that is free of any wiring or other obstructions. Make a small hole in the surface near the center of the chosen location to verify that it is suitable for mounting.
2. Use a level and masking tape to attach the included installation template to the surface at the chosen location. Ensure that the template is level before proceeding.
3. Using the **Anchor Holes** locations on the template as a reference, drill two pilot holes into the mounting surface.

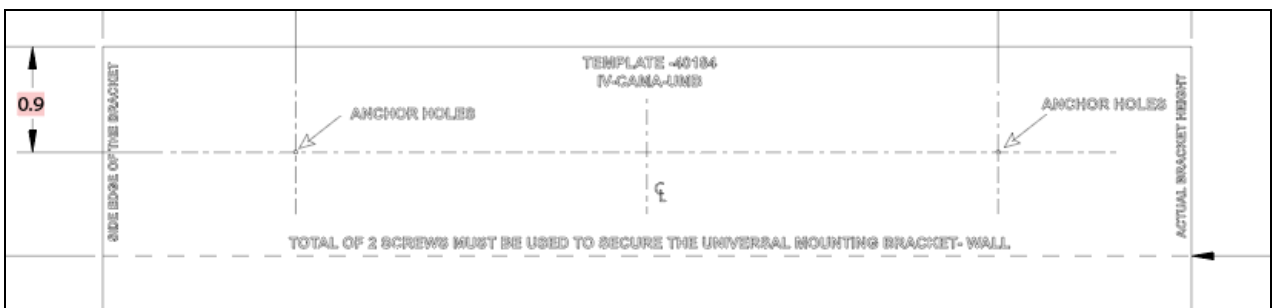

4. Install two of the included drywall anchors into the pilot holes.
5. If routing cables to the camera through the wall, make a suitable hole in the mounting surface.

6. Detach the small plastic cable cover on the rear of the mount.
7. Detach the large plastic cable cover from the top of the mount.

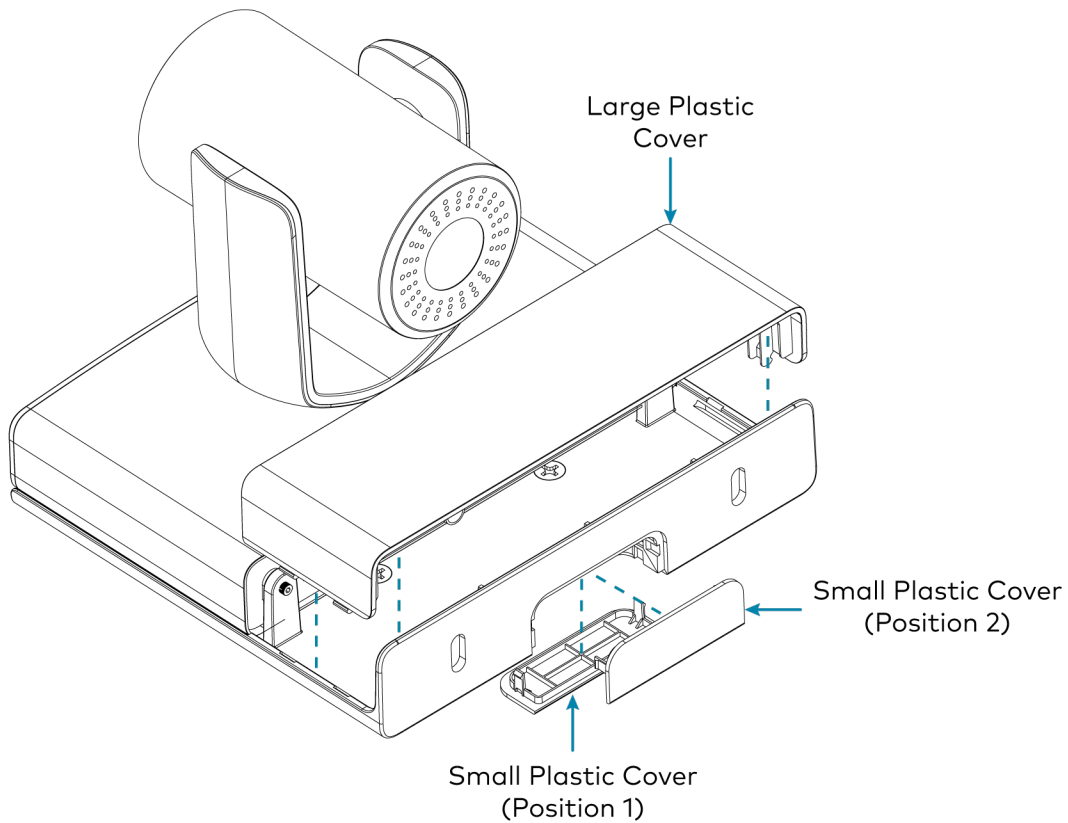

8. Insert the two included M2.5 x 12 mm hand screws through the standoff holes on each side of the mount.

NOTE: Do not tighten the screws into the camera; this is performed later in the procedure.

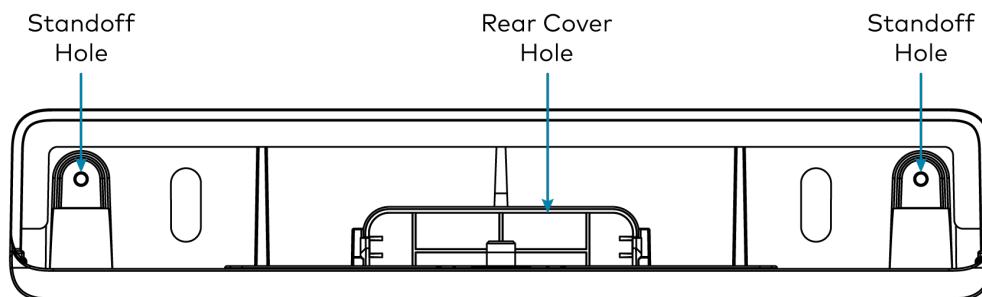

9. Route the cables through the rear cover hole.

10. Screw two of the included 6.3 x 38 mm screws through the rear holes of the mount into the drywall anchors in the wall.

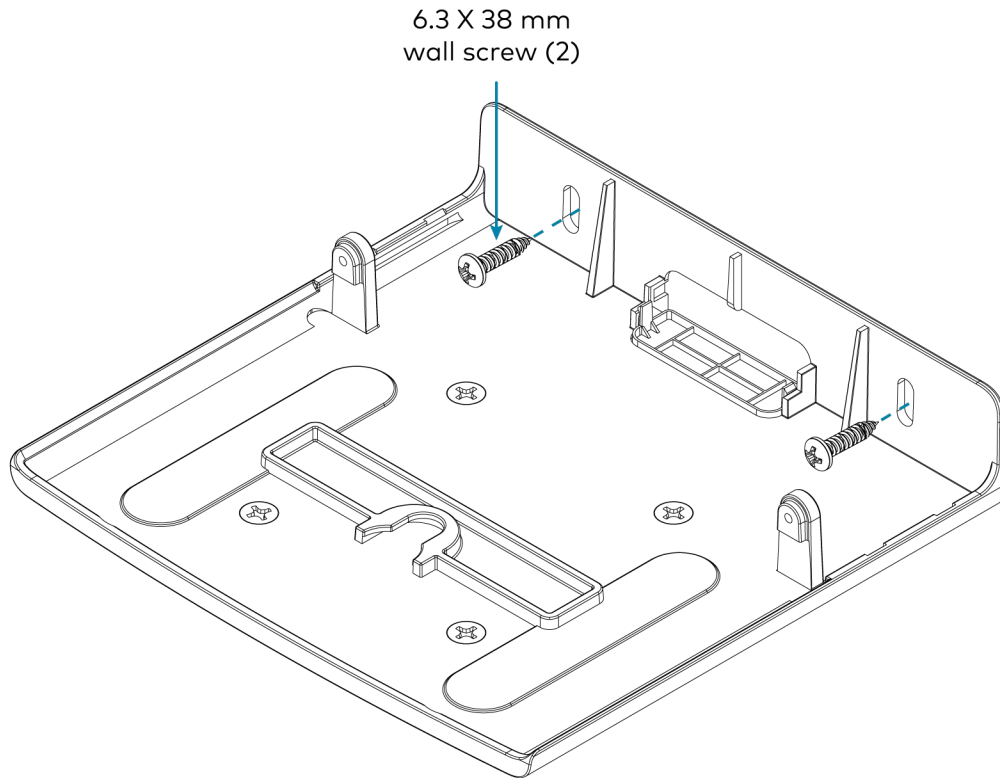

11. Connect all required cabling into the camera. For more information about the required cabling, refer to [Connect the Camera on page 100](#).

- Attach the included release plate to the bottom of the camera. Then, tighten the included 1/4-20 x 3/8 in. screw onto the release plate.

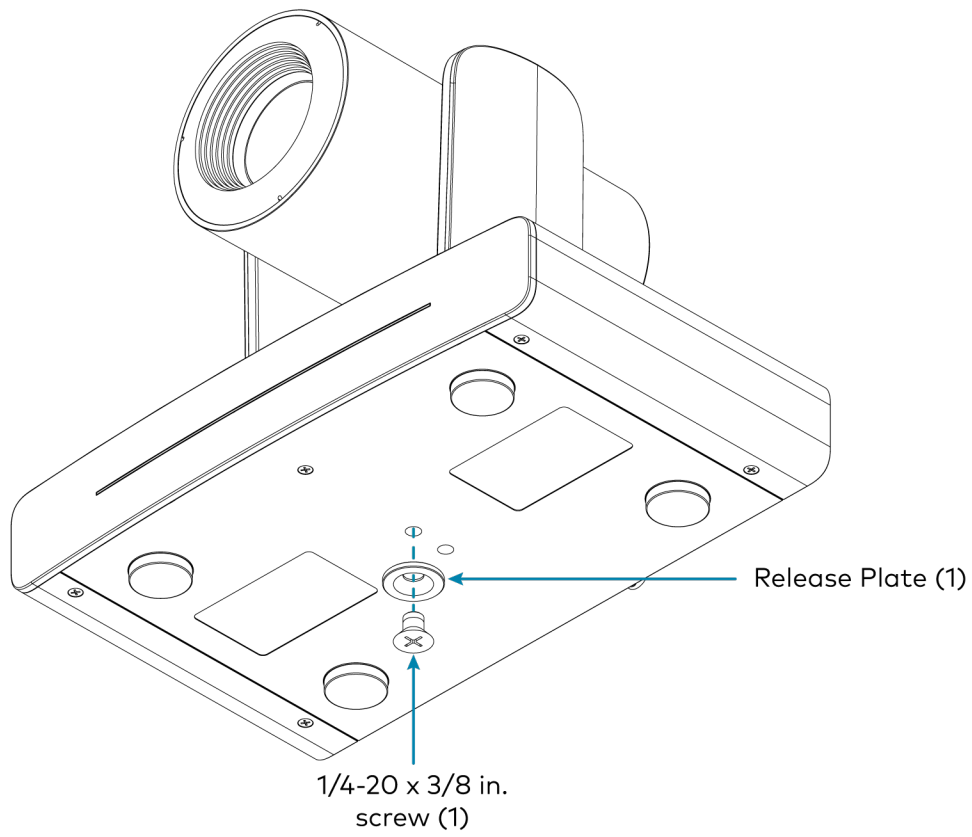

13. Slide the camera at a slight angle onto the mount so that the camera ports are facing the rear mounting holes.

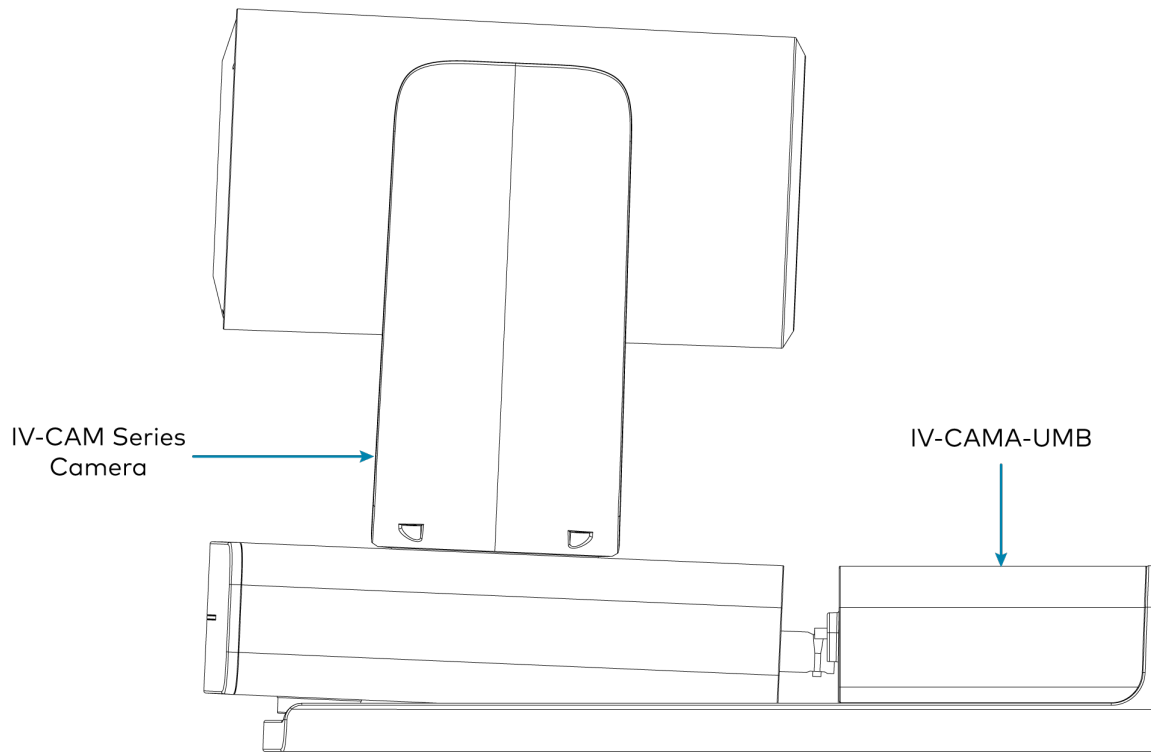

14. Tighten the two included M2.5 x 12 mm hand screws into the rear standoff holes on the camera.

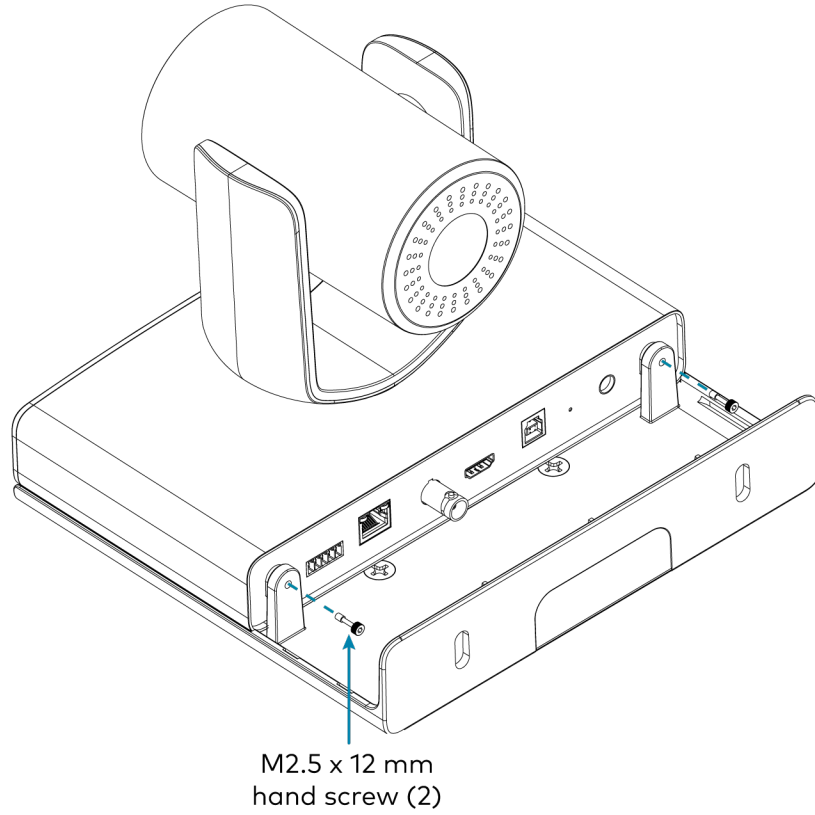

15. Attach the small plastic cable cover into Position 1.

16. Attach the large top cover to the top of the mount.

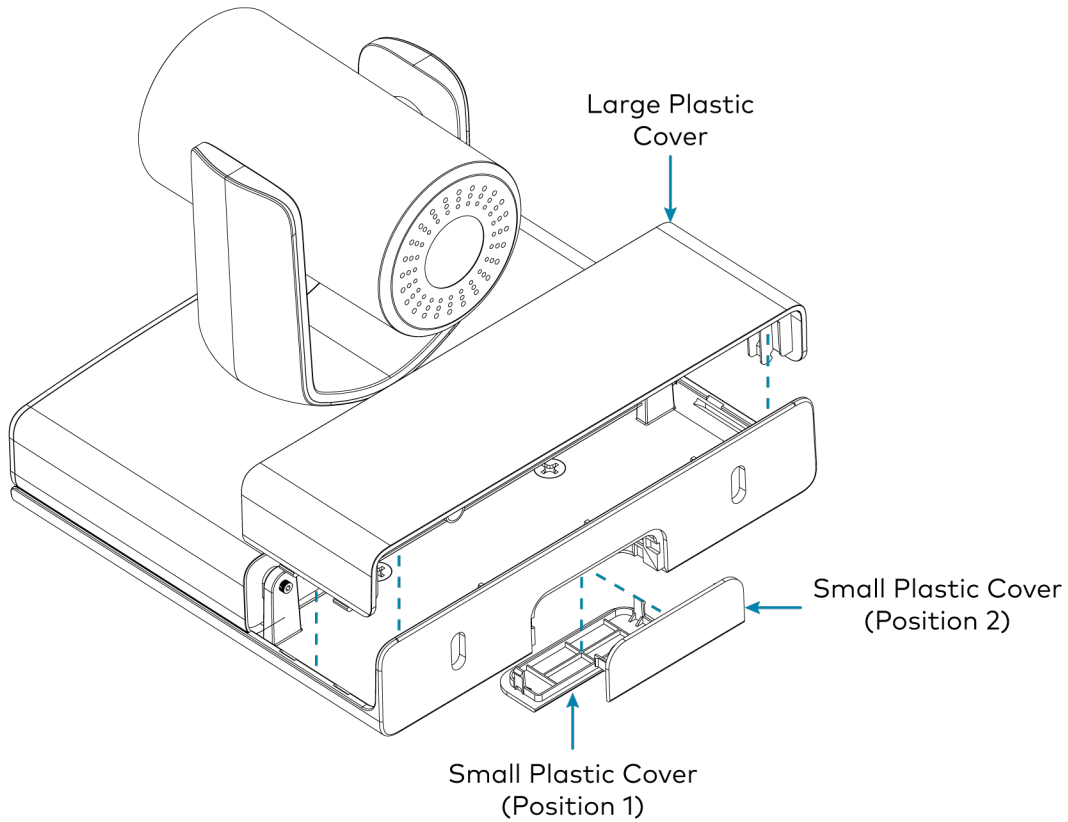

IV-CAMA-UMB Ceiling Installation

Use the following procedure to install the IV-CAMA-UMB to the ceiling:

NOTE: Only install the IV-CAMA-UMB to a drywall or hard wall ceiling. If mounting to a ceiling tile, a 90 x 90 VESA mount is suggested.

1. Choose a mounting location that is free of any wiring or other obstructions. Make a small hole in the surface near the center of the chosen location to verify that it is suitable for mounting.
2. Use a level and masking tape to attach the included installation template to the surface at the chosen location. Ensure that the template is level before proceeding.

- Using the **Anchor Holes** locations on the template as a reference, drill four pilot holes into the mounting surface.

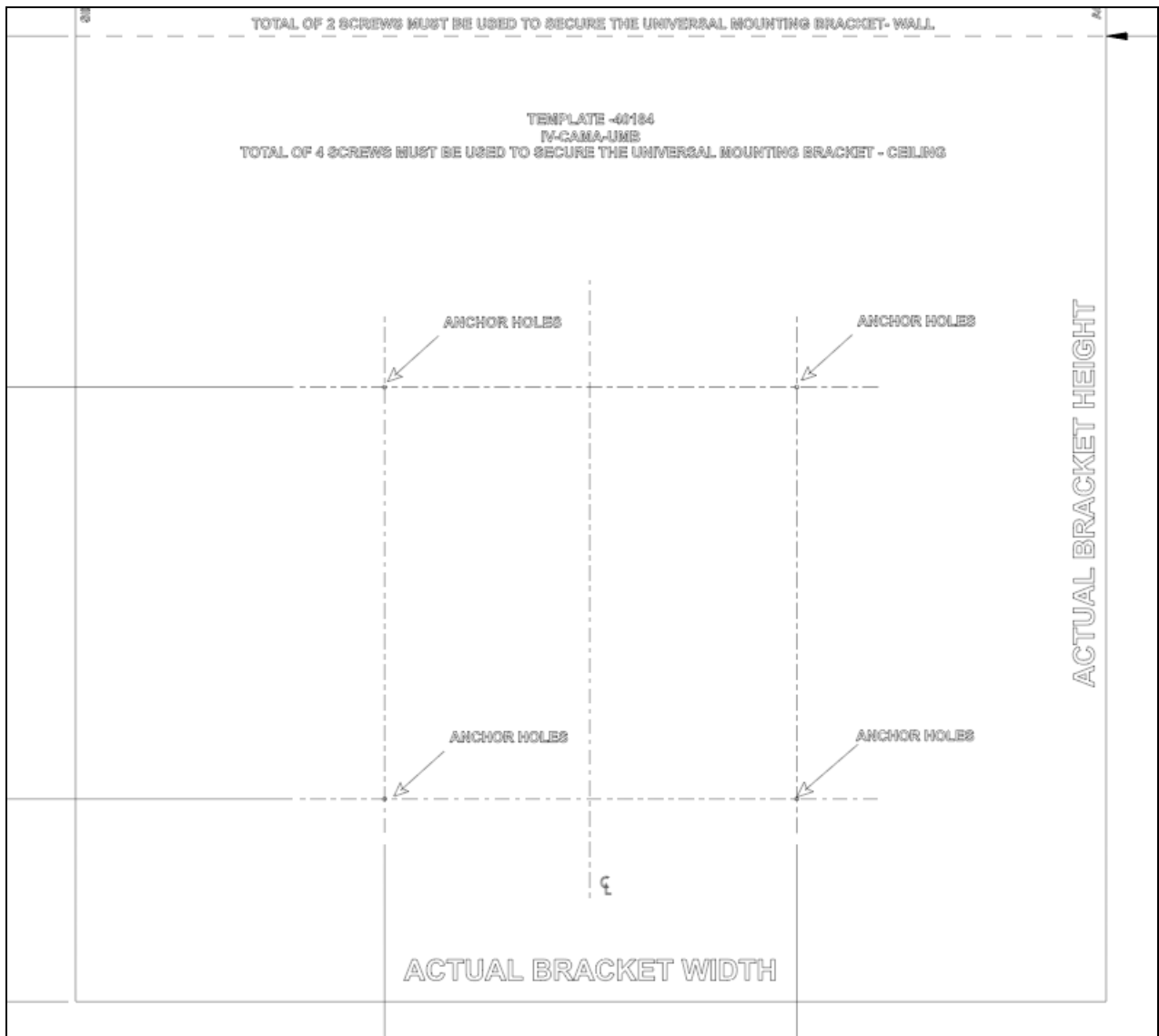

- If routing cables to the camera through the ceiling, make a suitable hole in the mounting surface.

5. Attach the mount onto the ceiling using four screws and anchors (not included). Choose the mounting hardware length and type in accordance with building specifications.

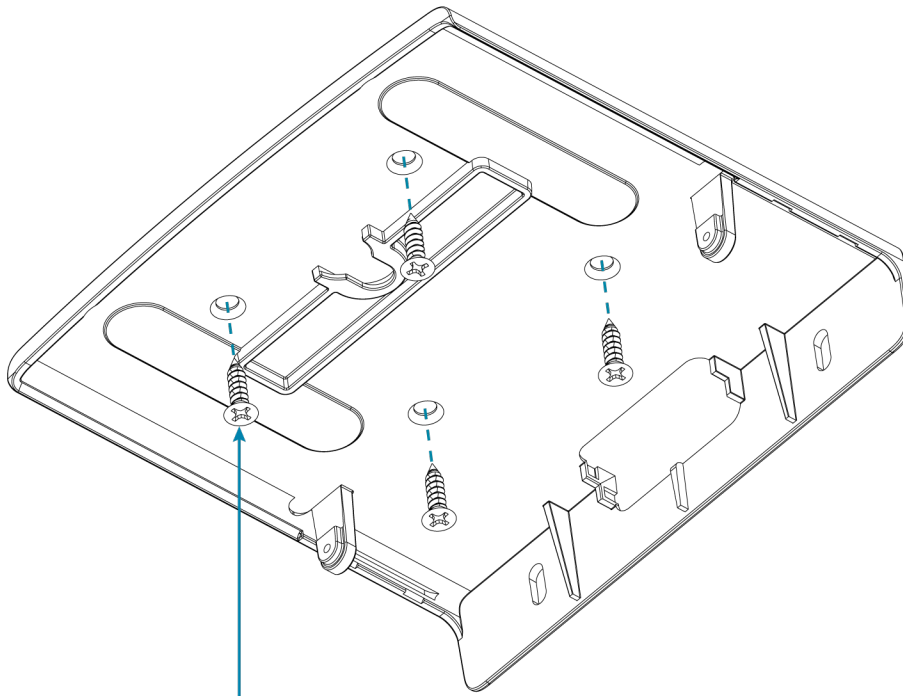

Mounting screw (4)
(not included)

6. Detach the small plastic cable cover on the rear of the mount.

7. Detach the large plastic cable cover from the top of the mount.

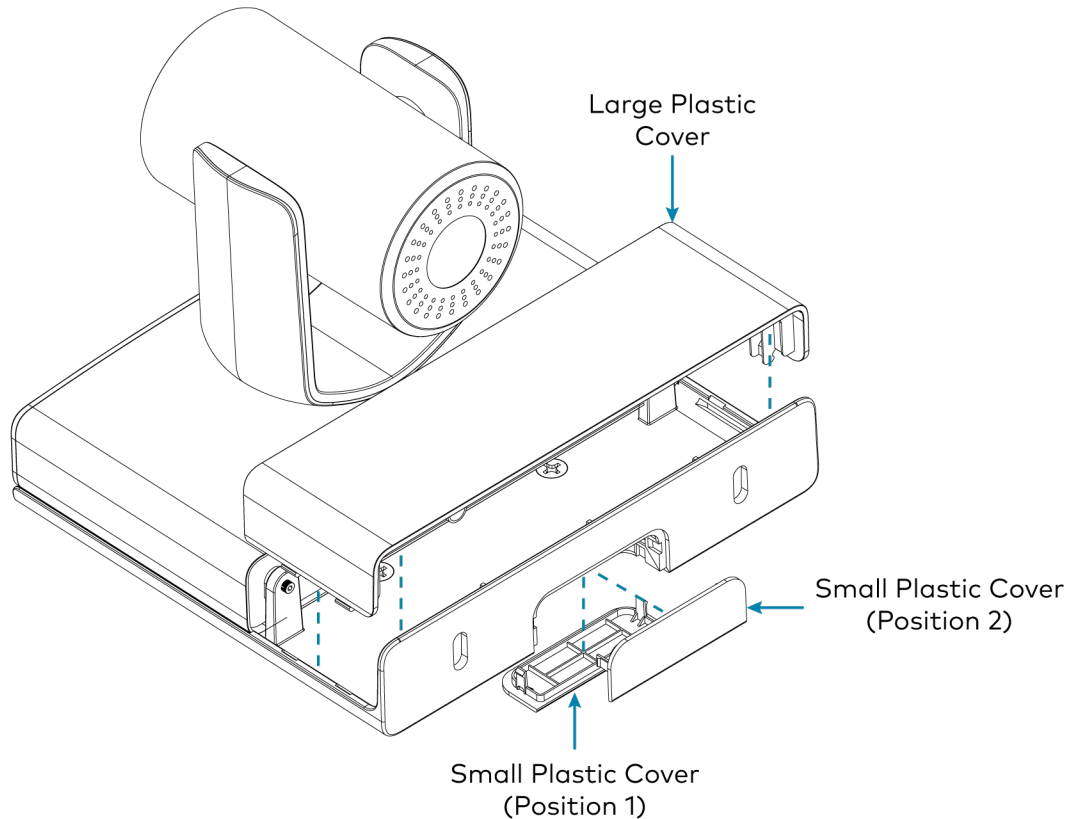

8. Route the cables through the bottom cover hole.
9. Insert the two included M2.5 x 12 mm hand screws through the standoff holes on each side of the mount.

NOTE: Do not tighten the screws into the camera; this is performed later in the procedure.

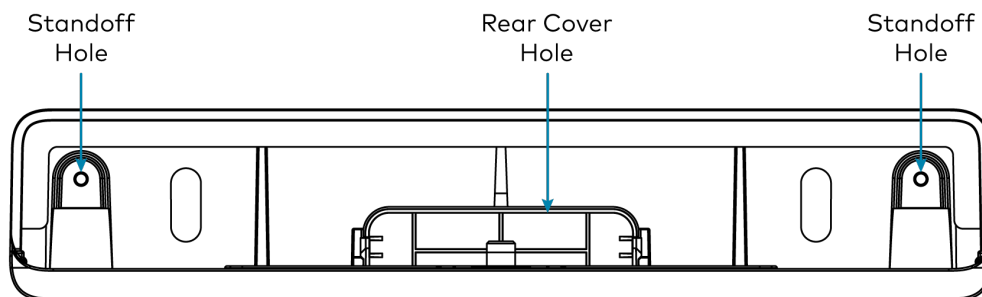

10. Connect all required cabling into the camera. For more information about the required cabling, refer to [Connect the Camera on page 100](#).

11. Attach the included release plate to the bottom of the camera. Then, tighten the included 1/4-20 x 3/8 in. screw onto the release plate.

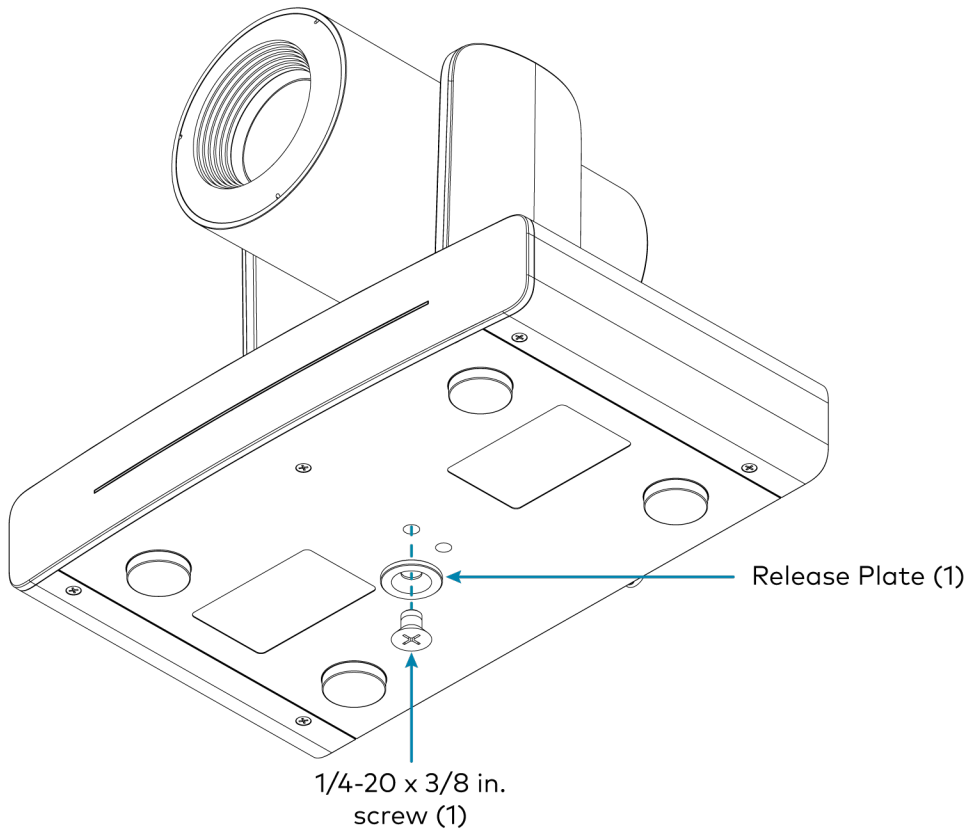

- Slide the camera at an angle onto the mount so that the camera ports are facing the rear mounting installation holes.

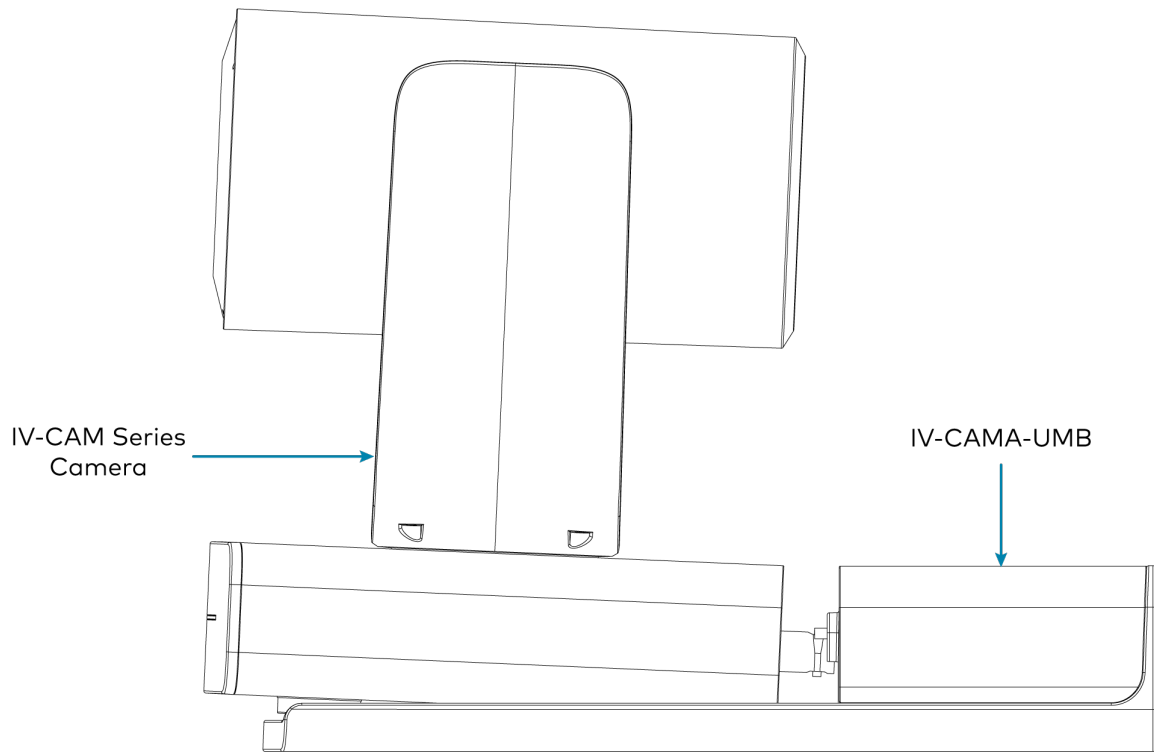

13. Tighten the two included M2.5 x 12 mm hand screws into the rear standoff holes on the camera.

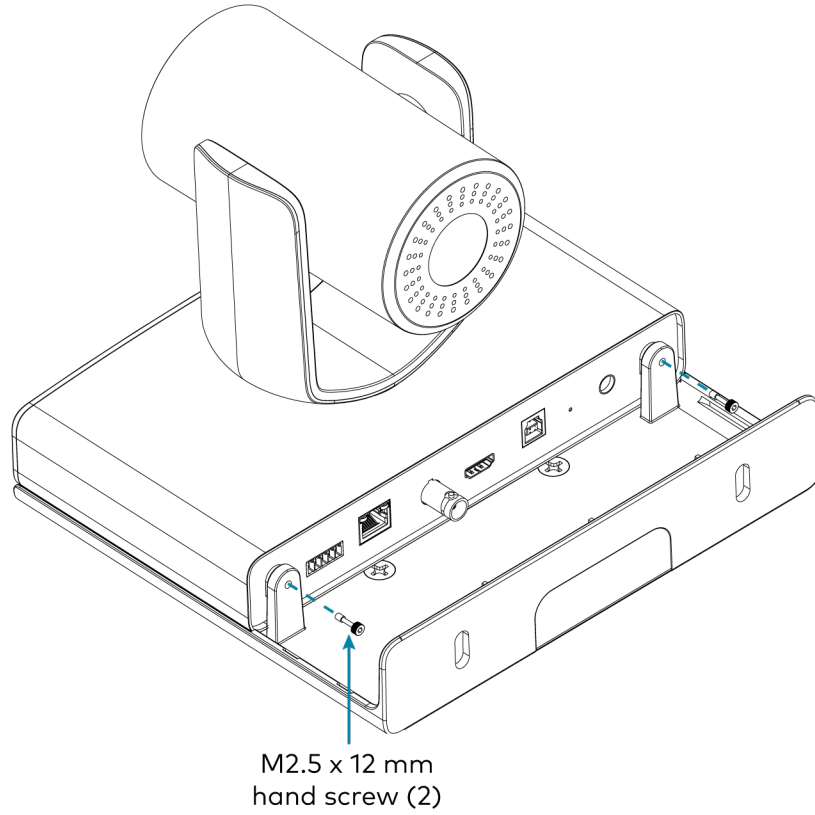

14. Attach the small plastic cable cover into Position 2.

15. Attach the large top cover to the top of the mount.

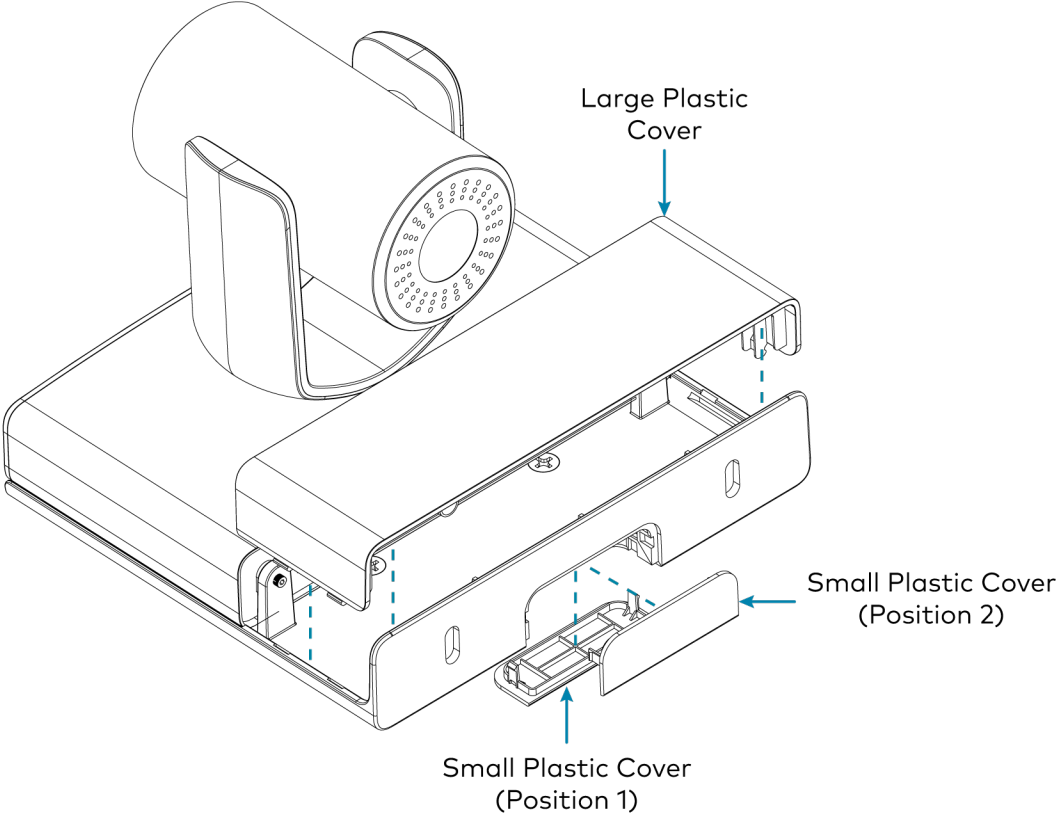

IVA-WMT-BRKT-1B Installation

The IVA-WMT-BRKT-1B Wall Mount Bracket is used to mount Crestron 1 Beyond cameras to the wall when a camera tilt is required. The mounting plate attached to the camera can be tilted to center the camera shot.

To mount the camera to a wall using the IVA-WMT-BRKT-1B Wall Mount Bracket:

1. Choose a mounting location that is free of any wiring, studs, or other obstructions. Make a small hole in the surface near the center of the chosen location to verify that it is suitable for mounting.
2. Use a level and the wall mount as a template to position the pilot holes. Ensure that the wall mount is level before proceeding.

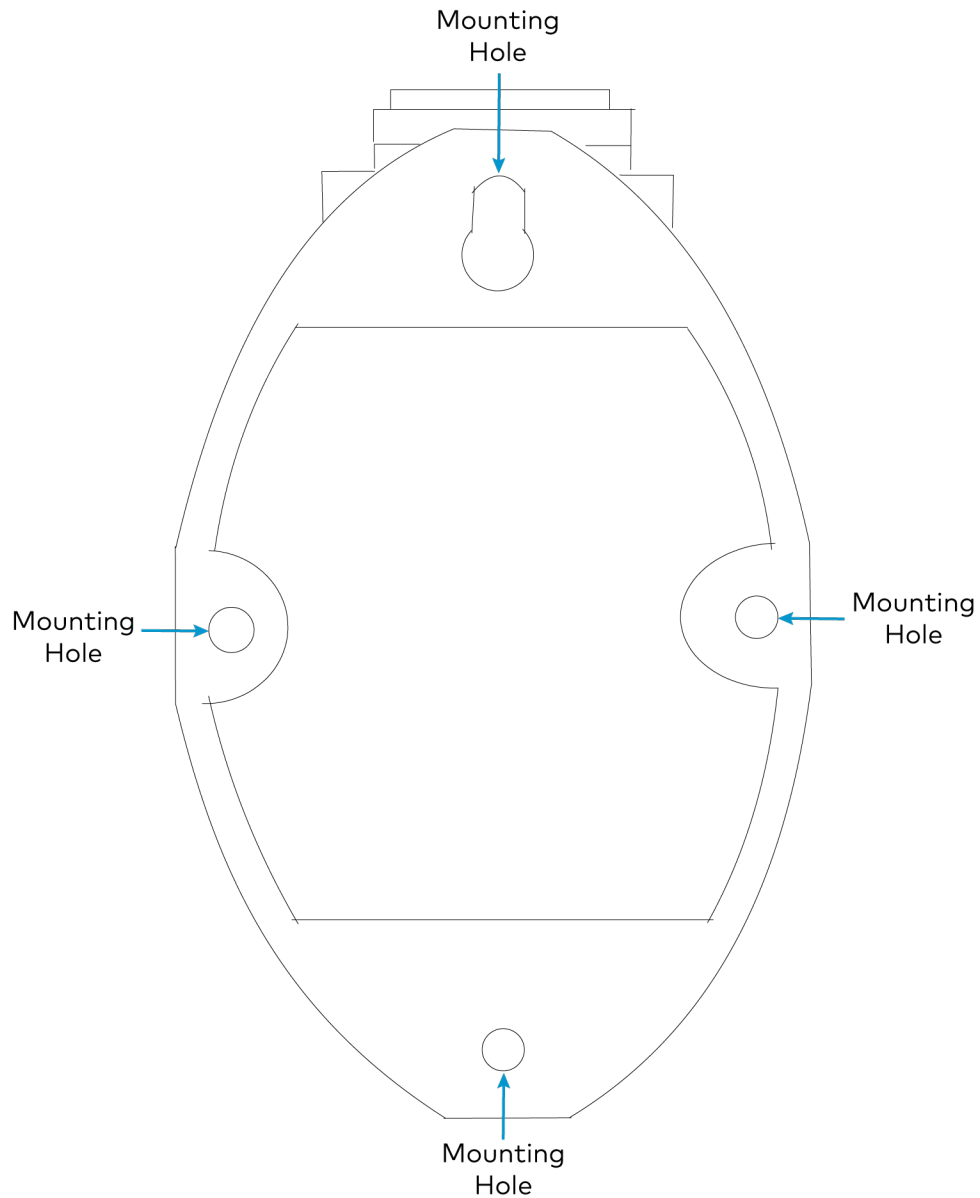

3. Using the four mounting holes on the mount, drill 4 pilot holes in the wall.
4. If routing cables to the camera through the wall, make a suitable hole in the mounting surface.
5. Insert the required cables for the camera through the rear of the mount to the open hole near the camera plate.
6. Install four drywall anchors (not included) into the pilot holes.
7. Attach the mount onto the wall using the four included screws.
8. Use the included screw to fix the camera on the camera mount plate.

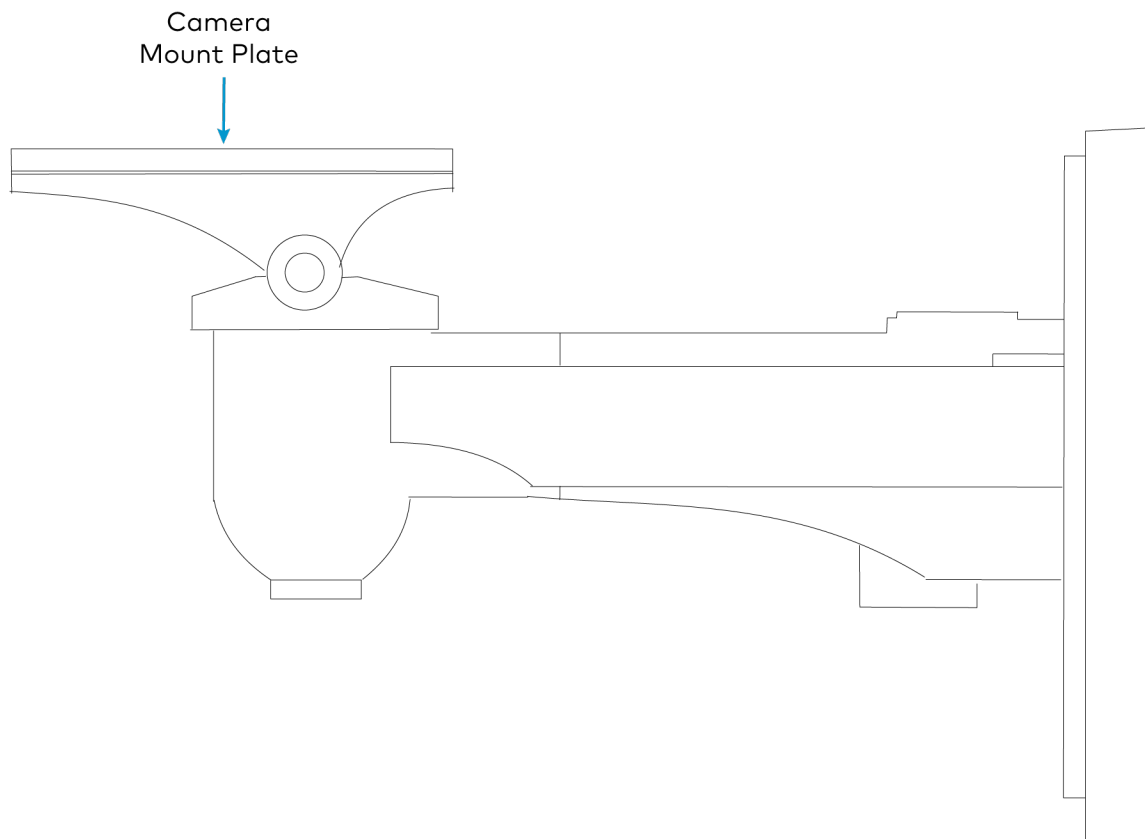

- Use a 4 mm Allen Key wrench to loosen the hinge bolt on the side of the camera mount.

NOTE: If the camera plate is not centered horizontally (0° X-axis), the Allen Key pivot bolt underneath the camera plate can be used to correct the positioning.

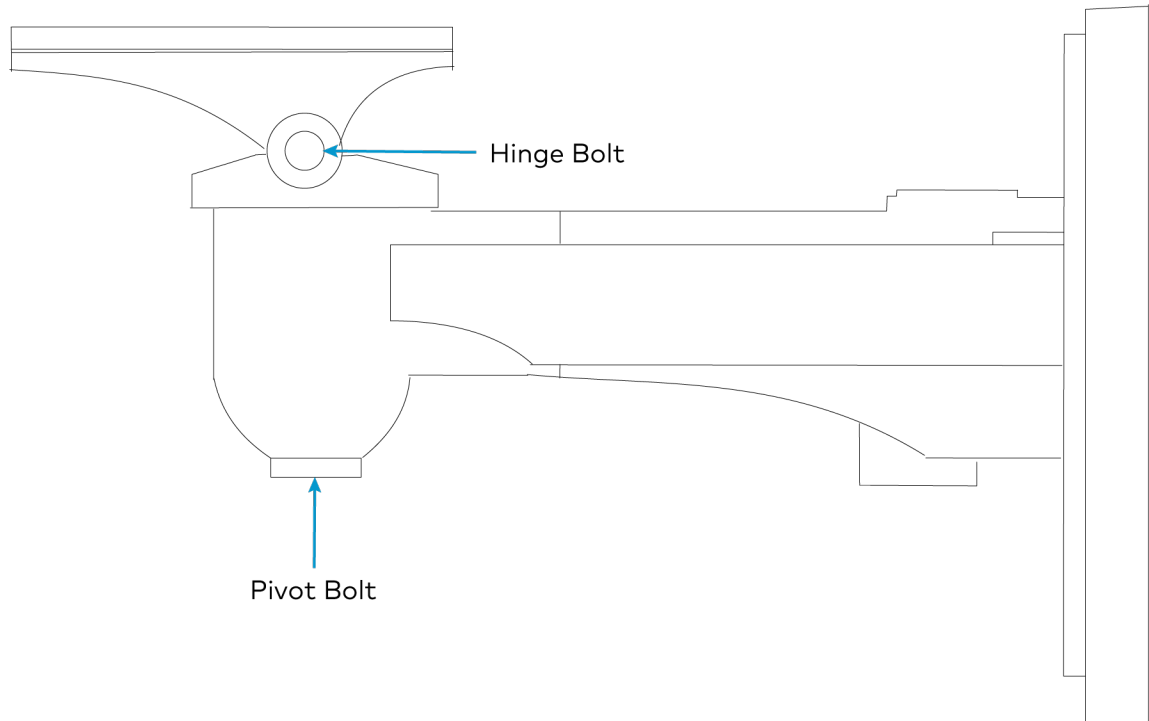

- Tilt the camera mount plate to achieve the desired camera tilt. For information on tilt angles for cameras, refer to [Mounting Measurements on page 77](#)
- Tighten the Allen Key bolt once the desired camera tilt is achieved.

IVA-CMT-BRKTJ-1B Installation

The IVA-CMT-BRKTJ-1B J-Mount Ceiling Bracket is used to suspend Crestron 1 Beyond cameras from the ceiling. The IVA-CMT-BRKTJ-1B is typically used to mount cameras from the ceiling when the camera cannot be inverted.

To mount the camera to a ceiling using the IVA-WMT-BRKT-1B J-Mount Ceiling Bracket:

NOTE: Only install the IVA-CMT-BRKTJ-1B to a drywall or hard wall ceiling. If mounting to a ceiling tile, a 90 x 90 VESA mount is suggested.

To mount the camera:

1. Choose a mounting location that is free of any wiring, studs, or other obstructions. Make a small hole in the surface near the center of the chosen location to verify that it is suitable for mounting.

2. Use a level and the J-Mount as a template to position the pilot holes. Ensure that the J-Mount is level before proceeding.

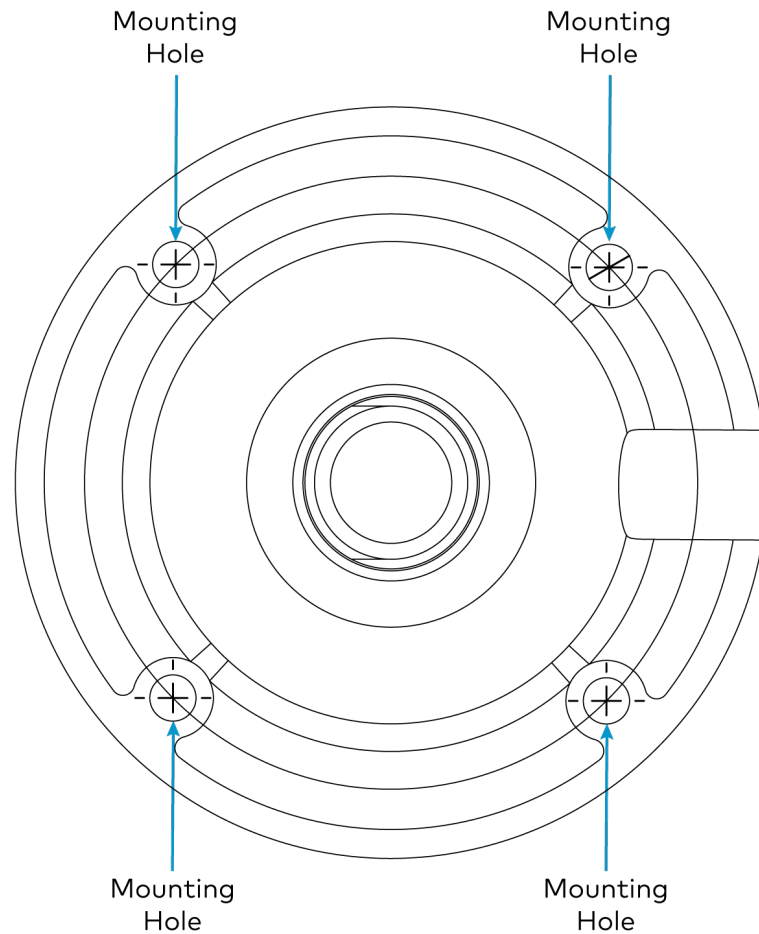

3. Using the four mounting holes on the mount, drill 4 pilot holes in the ceiling.
4. Place four drywall anchors (not included) into the pilot holes.
5. Attach the mount onto the ceiling using four screws (not included). Choose the screw length and type in accordance with building specifications.
6. If desired, a single cable can be routed through the J-Mount to the camera plate. Route the cable through the mount to the hole near the camera plate.

7. Screw the J-mount into the ceiling mounted bracket.

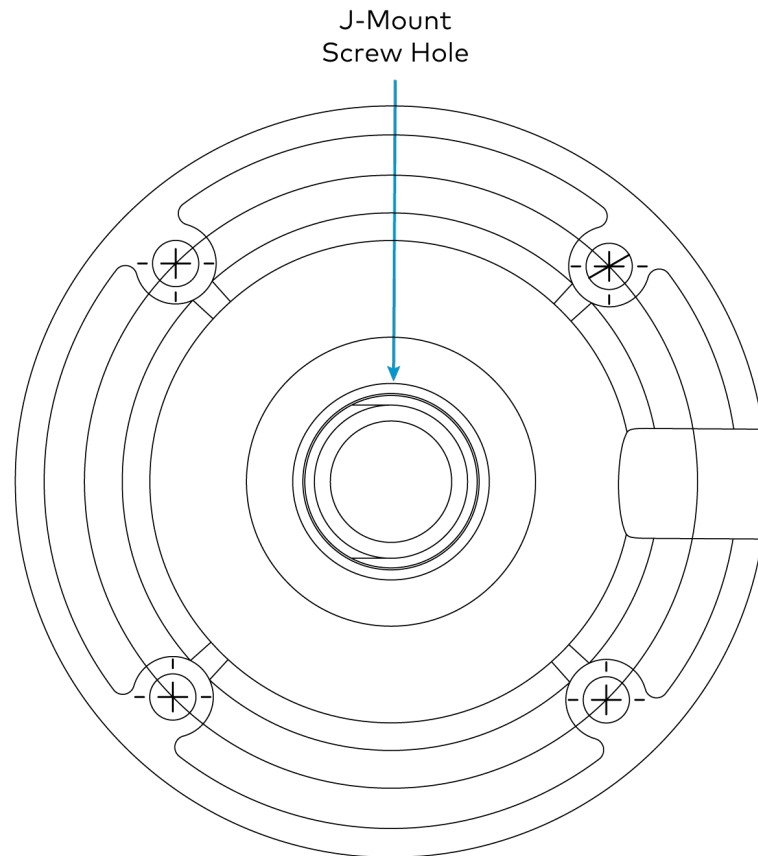

8. Use a Phillips® screwdriver to loosen the 2 x 1-1/2 in. screw near the bend on the J-Mount. Then, pull or retract the J-Mount to the desired length. Ensure that the 2 x 1-1/2 in. screw is retightened before proceeding.
9. Use the included screw to fix the camera on the camera mount plate.
10. Use a Phillips screwdriver to loosen the two 2 x 1-1/2 in. screws on both sides of the camera plate.
11. Tilt and pan the camera mount plate to achieve the desired camera plate angle. For information on tilt angles for cameras, refer to [Mounting Measurements on page 77](#)

Connect the Camera

Refer to the following sections for more information on the required and optional camera connections.

CAUTION: To avoid damage and ensure optimal performance of the camera:

- Check the source power before powering on the camera. IV-CAM series cameras can be powered via a 15.4 W PoE switch or with the [PW-1225DU](#) 12VDC power supply (sold separately). Under or overpowering the camera will cause damage and poor performance that may not be immediately visible. If a PoE switch used, be sure the port is properly configured for 15.4 W. If using DC power and connecting to a network switch, be sure the port is not set for PoE.
- Do not power the camera with PoE and a power supply at the same time. Doing so may cause it to malfunction.

Camera Ports

Route all necessary cables to the camera as described in the installation instructions for the chosen mounting accessory (refer to [Install the Mounting Hardware on page 79](#)). Then, make all connections to the rear of the camera as shown in the following image.

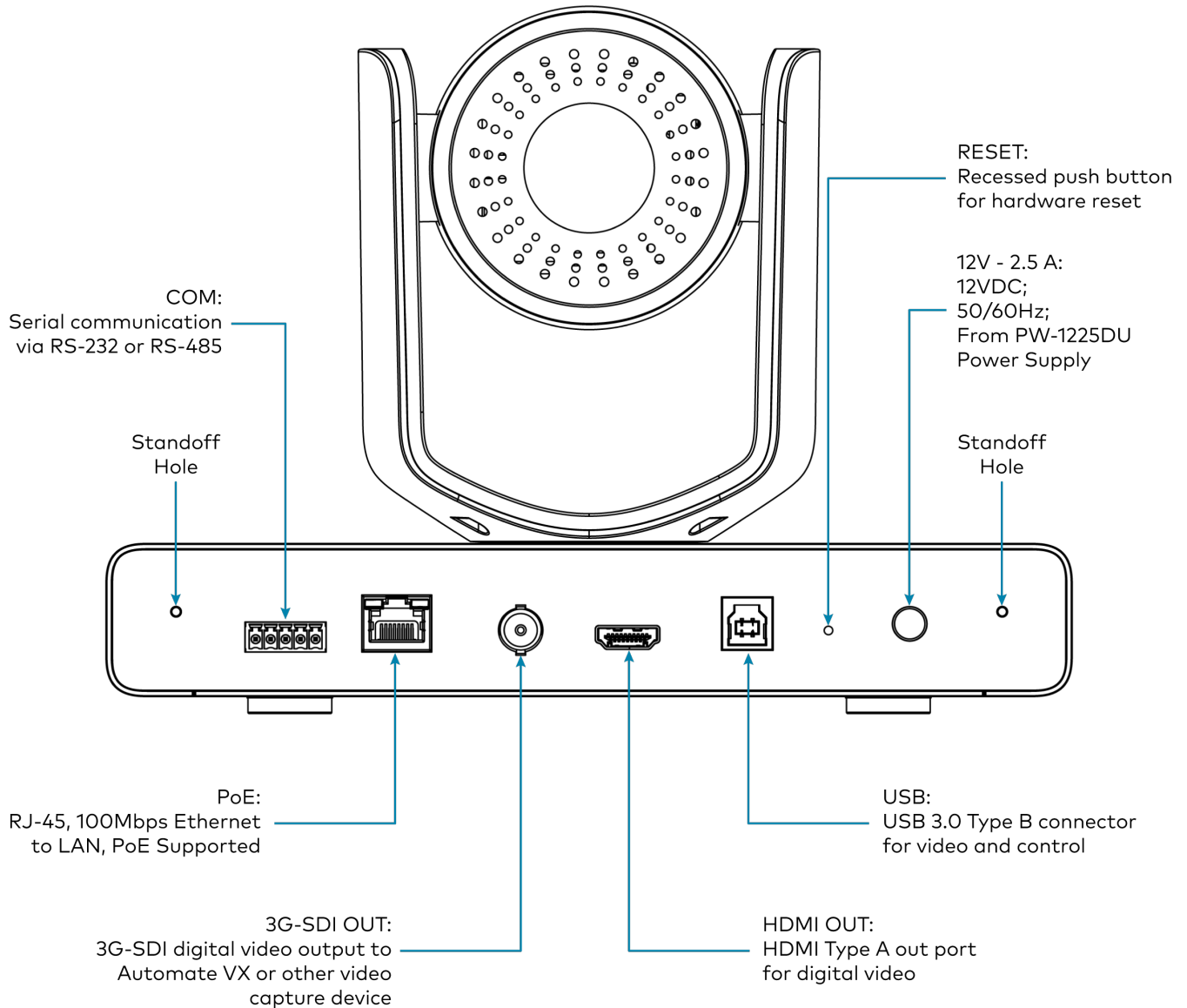

Network Connection

A network connection enables easy configuration and control from any computer connected to the same network, and access to the camera's IP video streams. Use a CAT5e (or greater) cable to connect the camera to the network or directly to the host computer used for configuration. The camera by default is set to DHCP.

NOTE: Use shielded CAT5e (or greater) cables when running the cable over long distances and/or if NDI is used.

PoE Power

Crestron 1 Beyond camera support control, streaming, and power over a single Ethernet cable. If using a network switch, ensure that it is PoE certified and that it can supply 15.4 W for each connected camera. Alternatively, a PoE injector can be used to inject power between the switch and camera.

NOTE: To comply with the European Directive (CE), shielded CAT5e cable must be used as a minimum for PoE power.

DC Power

Power the Crestron 1 Beyond camera using the [PW-1225DU](#) 12VDC power supply (sold separately). The camera cannot operate properly with less than 12VDC power. Since voltage drops over distance, the PW-1225DU power adapter is not sufficient if the power source is greater than 10 ft (3 m) from the camera. Do not use the PW-1225DU 12VDC power supply and PoE simultaneously.

CAUTION: Providing too little or too much power can damage the camera. For PoE, make sure the network port is configured for 15.4 W. For DC power, be sure to supply 12V to the camera.

Video Output

Crestron 1 Beyond cameras have multiple video output options, and all video outputs are available simultaneously. Refer to the following sections for information regarding video outputs.

TIP: When cameras are connected via HDMI or 3G-SDI for video output, the IP address of the camera is shown momentarily on the video output display when the camera is powered on.

USB 3.0

Connect the camera to a computer using a USB 3.0 cable. It will be detected by your operating system and become selectable in all applications supporting USB cameras.

3G-SDI

The rear of the camera has one 3G-SDI port to use with standard 3G-SDI cabling (RG-6 Coax cable, 75 Ω with BNC male connectors). Depending on specific building fire codes, cables may need to be plenum rated.

HDMI

The camera can be connected with an HDMI® cable to a conferencing codec or capture device via the rear HDMI port on the camera.

Serial Control

The IV-CAM Series camera supports serial control over RS-485 and RS-232. The serial connection is for sending remote commands to the camera using the VISCA, PELCO_D, or PELCO_P protocols from a control system. In most cases, serial cabling is optional because control of the camera is done through a network connection.

If serial control is required, it is recommended to use RS-485. RS-485 can support cable lengths of up to 4,000 ft while RS-232 is limited to cable distances of 50 ft. Also, RS-485 can support up to 32 controller devices while RS-232 only supports one.

22 or 24 AWG twisted pair cable is recommended for serial control. Depending on specific building fire codes, cables may need to be plenum rated.

To wire serial control, use the terminal block (included) with a serial cable. Then, connect the ends of the cable into the camera and the control device being used.

IV-CAM-I12D-B Installation

The IV-CAM-I12D-B Crestron 1 Beyond i12D Camera can be mounted to the wall as a camera shelf mount or it can be placed on a tabletop or similar flat surface.

Refer to the following sections for more information on mounting the IV-CAM-I12D-B.

IV-CAM-I12D-B Installation Requirements

The IV-CAM-I12D-B camera has additional installation requirements:

- The IV-CAM-I12D-B camera cannot be inverted.
- The fixed wide-angle camera lens must be able to view the entire subject area as it is used by the tracking algorithm for visual AI.
- Ensure that the camera is at least 5 ft away from the closest meeting participant.

IV-CAM-I12D-B Tabletop Installation

The IV-CAM-I12D-B can be placed onto a tabletop or similar flat surface. When surface mounting the IV-CAM-I12D-B, ensure it is placed as close as possible to the front edge of the surface. Poor speaker tracking detection due to inaccurate spacial audio may occur if the camera is placed too far back on the surface.

IV-CAM-I12D-B Wall Installation

To install the IV-CAM-I12D-B to the wall with the included wall mount:

IV-CAM-I12D-B Mount

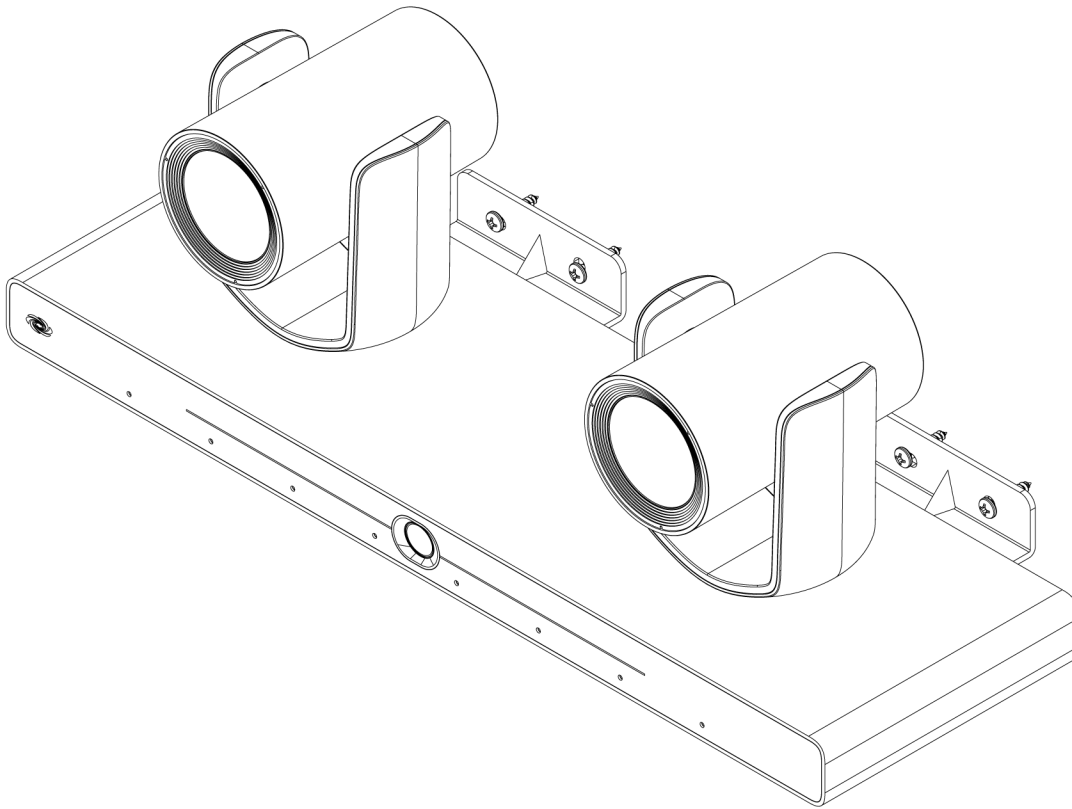

1. Choose a mounting location that is free of any wiring or other obstructions. Make a small hole in the surface near the center of the chosen location to verify that it is suitable for mounting.
2. Use a level and the wall mount as a template to mark four pilot holes. Ensure the pilot holes are aligned with the four wall mount holes and that the mount is level before proceeding.
3. Drill four pilot holes into the mounting surface using the locations marked in step 2.
4. If routing cables to the camera through the wall, make a suitable hole in the mounting surface.
5. Insert the required cables for the camera through the rear of the mount to the open hole near the camera plate.
6. Install four drywall anchors (not included) into the pilot holes.

7. Attach the mount onto the wall using the four included M6*40 screws.

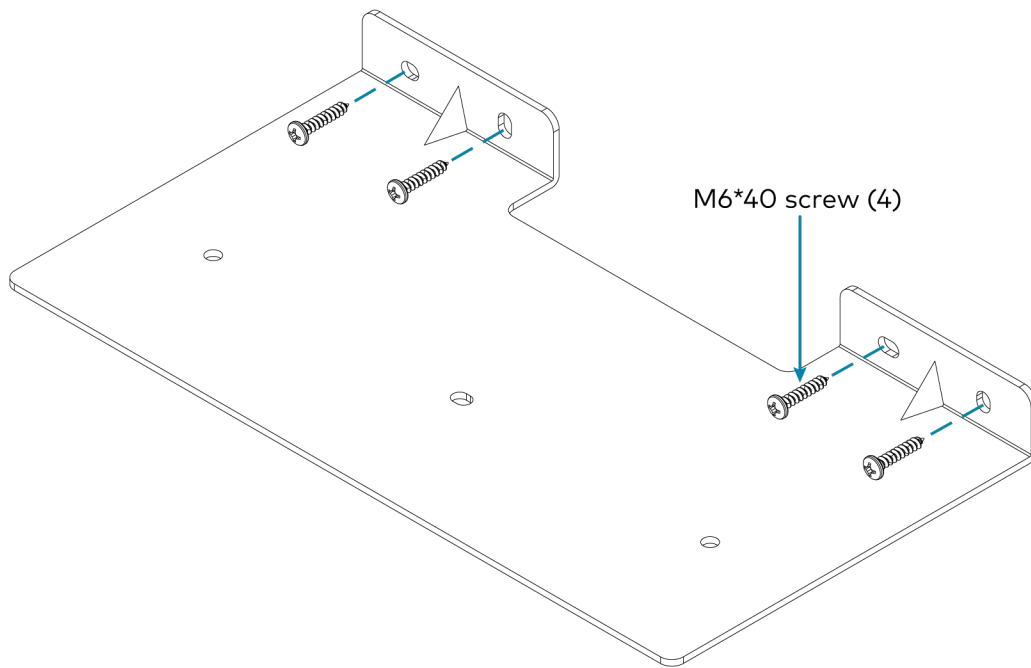

8. Align the three threaded screw holes in the bottom of the IV-CAM-I12D-B with the three bottom plate holes in the wall mount.

9. Attach the IV-CAM-I12D-B to the mount using the three included 1/4-20UNC x 8mm screws.

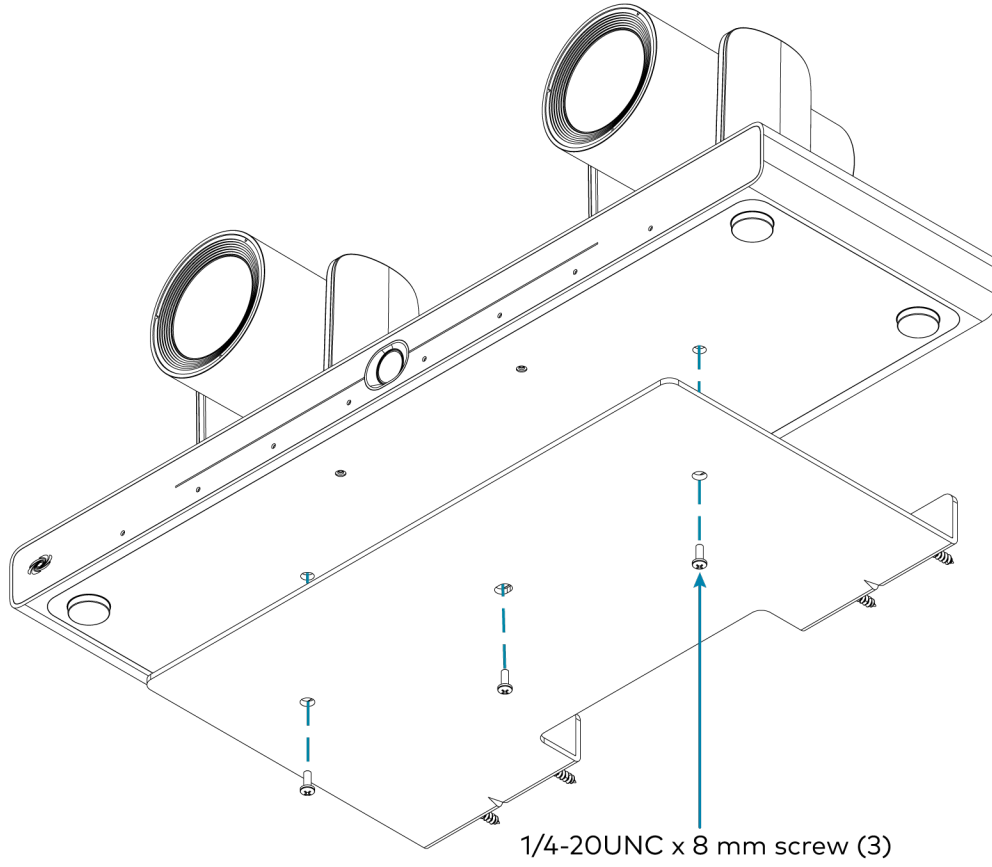

Connect the IV-CAM-I12D-B Camera

Refer to the following sections for more information on the required and optional camera connections.

Camera Ports

Route all necessary cables to the IV-CAM-I12D-B as described in the installation instructions for the included mounting accessory (refer to [IV-CAM-I12D-B Installation on page 104](#)). Then, make all connections to the rear of the camera as shown in the following image.

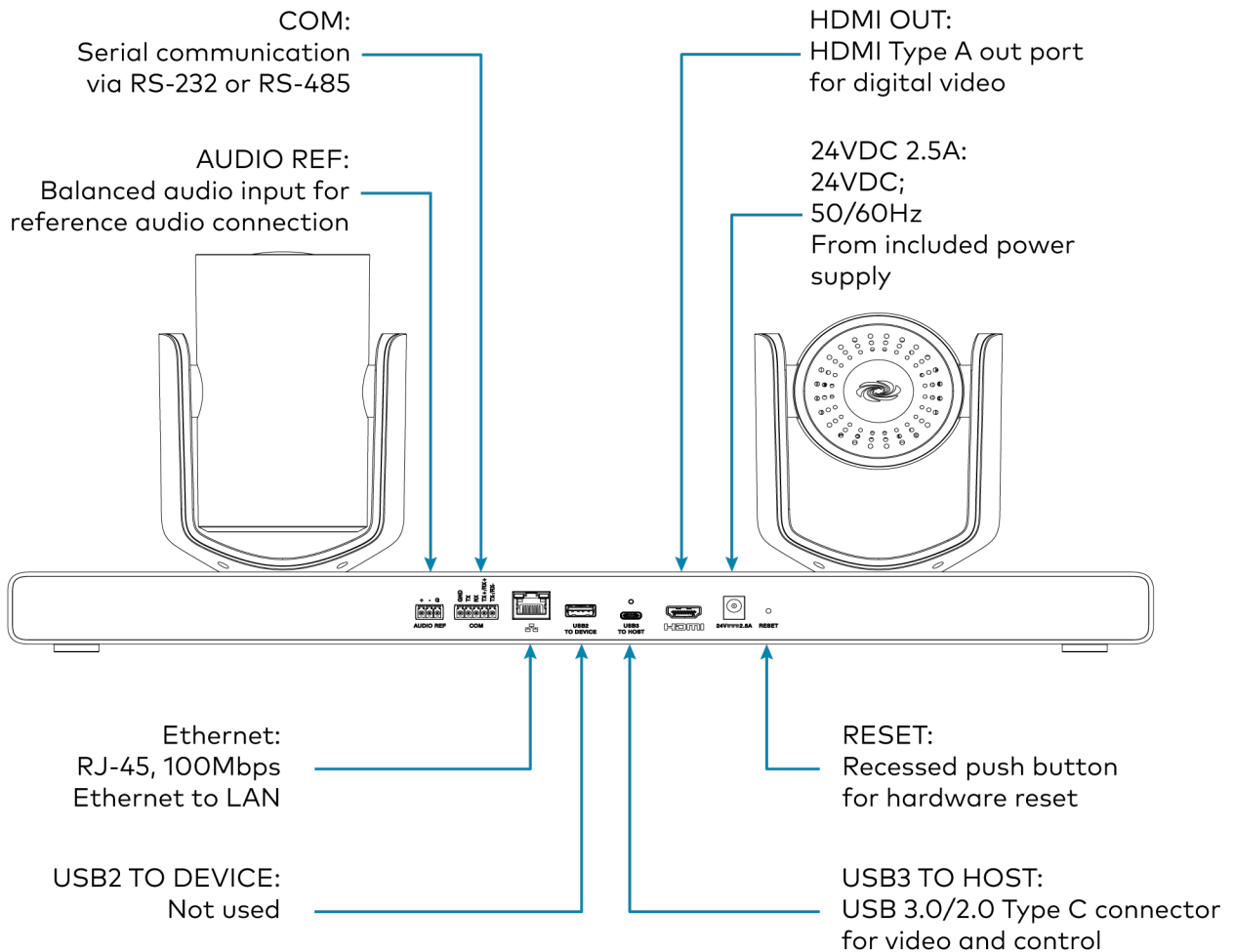

Network Connection

A network connection enables easy configuration and control from any computer connected to the same network, and access to the camera's IP video streams. Use a CAT5e (or greater) cable to connect the camera to the network or directly to the host computer used for configuration. The camera by default is set to DHCP.

Audio Reference

Audio coming from in room speakers can be sent to the IV-CAM-I12D-B to prevent unwanted camera switching. Failure to send in room audio to the camera causes poor camera performance during meetings.

Use either the 3-Pin balanced audio port (**AUDIO REF**) or input the IP address of the audio device into the camera's settings to send reference audio to the camera. For more information about connecting to the audio device via camera manager, refer to [Control Settings on page 180](#).

DC Power

Power the IV-CAM-I12D-B camera using the included 24VDC power supply. The camera cannot operate properly with less than 24VDC power. Since voltage drops over distance, the included power adapter is not sufficient if the power source is greater than 10 ft (3 m) from the camera.

CAUTION: Providing too little or too much power can damage the camera. Ensure 24V is supplied to the camera.

Video Output

The IV-CAM-I12D-B has multiple video output options, and all video outputs are available simultaneously. Refer to the following sections for information regarding video outputs.

TIP: When the IV-CAM-I12D-B is connected via HDMI for video output, the IP address of the camera is shown momentarily on the video output display when the camera is powered on.

NOTE: Picture-in-Picture in the camera output is unavailable at resolutions at and below 360p.

USB 3.0/2.0

Connect the camera to a computer using the included USB-C® to USB-A cable. It will be detected by your operating system and become selectable in all applications supporting USB cameras.

HDMI

The camera can be connected with an HDMI® cable to a conferencing codec or capture device via the rear HDMI port on the camera.

Serial Control

The IV-CAM Series camera supports serial control over RS-485 and RS-232. The serial connection is for sending remote commands to the camera using the VISCA, PELCO_D, or PELCO_P protocols from a control system. In most cases, serial cabling is optional because control of the camera is done through a network connection.

If serial control is required, it is recommended to use RS-485. RS-485 can support cable lengths of up to 4,000 ft while RS-232 is limited to cable distances of 50 ft. Also, RS-485 can support up to 32 controller devices while RS-232 only supports one.

22 or 24 AWG twisted pair cable is recommended for serial control. Depending on specific building fire codes, cables may need to be plenum rated.

To wire serial control, use the terminal block (included) with a serial cable. Then, connect the ends of the cable into the camera and the control device being used.

Configuration

The Crestron 1 Beyond Camera Manager 2 allows for the configuration and control of Crestron 1 Beyond Cameras.

This section provides the following information:

- [Initial Setup](#)
- [Device Configuration](#)

Initial Setup

Crestron 1 Beyond cameras require additional setup before configuring the camera.

NOTE: Ensure all connections have been made to the camera before proceeding. For more information about camera connections, refer to [Connect the Camera on page 100](#).

This section provides the following information:

- [Install Camera Manager Software](#)
- [Add Cameras](#)
- [Set a Static IP Address](#)
- [Update Firmware](#)
- [Change the Camera Mode](#)

Install Camera Manager Software

Use the following procedures to install the Crestron 1 Beyond Camera Manager 2 software.

System Requirements

Ensure the host computer running the software meets the following system requirements.

- Windows® 10 OS or later
- Dual-core processor
- 4GB (or greater) memory
- 1GB (or greater) storage
- Ethernet or Wi-Fi™ network connection to the local network

Installation

Follow the steps below to install the software.

1. Download the [Crestron 1 Beyond Camera Manager 2 installation package](#).
2. Open the installer executable file and follow all prompts to install the software.

Add Cameras

Use the following procedures to add Crestron 1 Beyond cameras to the Crestron 1 Beyond Camera Manager 2 software.

NOTE: Before adding cameras to the Crestron 1 Beyond Camera Manager 2 software, ensure that the software is first installed onto the computer. For more information on installing the Crestron 1 Beyond Camera Manager 2 software, refer to [Install Camera Manager Software on page 113](#)

- To access the camera manager main menu, refer to [Access the Main Menu on page 115](#).
- To add a new camera, refer to [Add a New Camera on page 117](#).
- To add a camera that has been used in the software previously, refer to [Add a Configured Camera on page 123](#).
- To add a camera manually with its network information, refer to [Manually Add a Camera on page 128](#).
- To delete a camera from the camera list, refer to [Delete Camera on page 131](#).
- To delete all cameras from the camera list, refer to [Delete All Cameras on page 133](#).
- To identify which cameras are associated with entries in the camera list, refer to [Identify Cameras on page 134](#).

Access the Main Menu

Open the Crestron 1 Beyond Camera Manager 2 software either by selecting the desktop icon, or by navigating to the directory of the local computer where the software was installed.

Desktop Icon



The following screen is displayed when the software opens.

Camera Manager

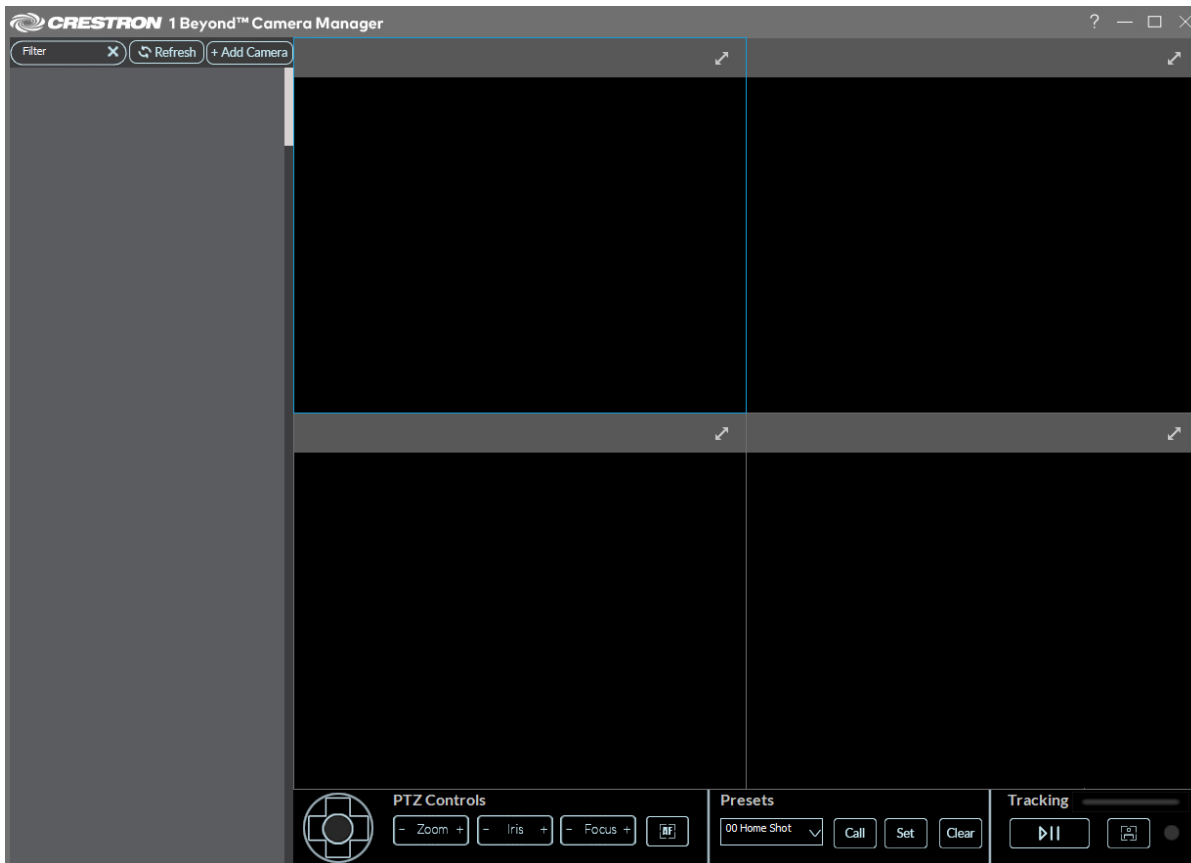

The camera list is located on the left side of the user interface.

Camera List

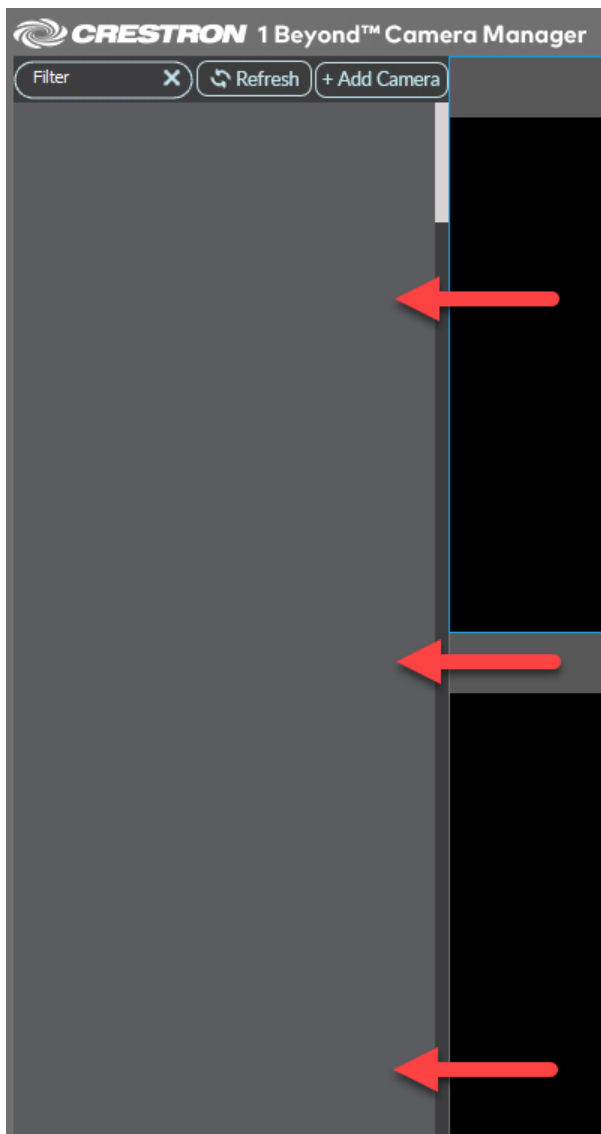

Add a New Camera

To add a new camera to the camera list:

1. Select **+ Add Camera** in the top left of the user interface.

+ Add Camera

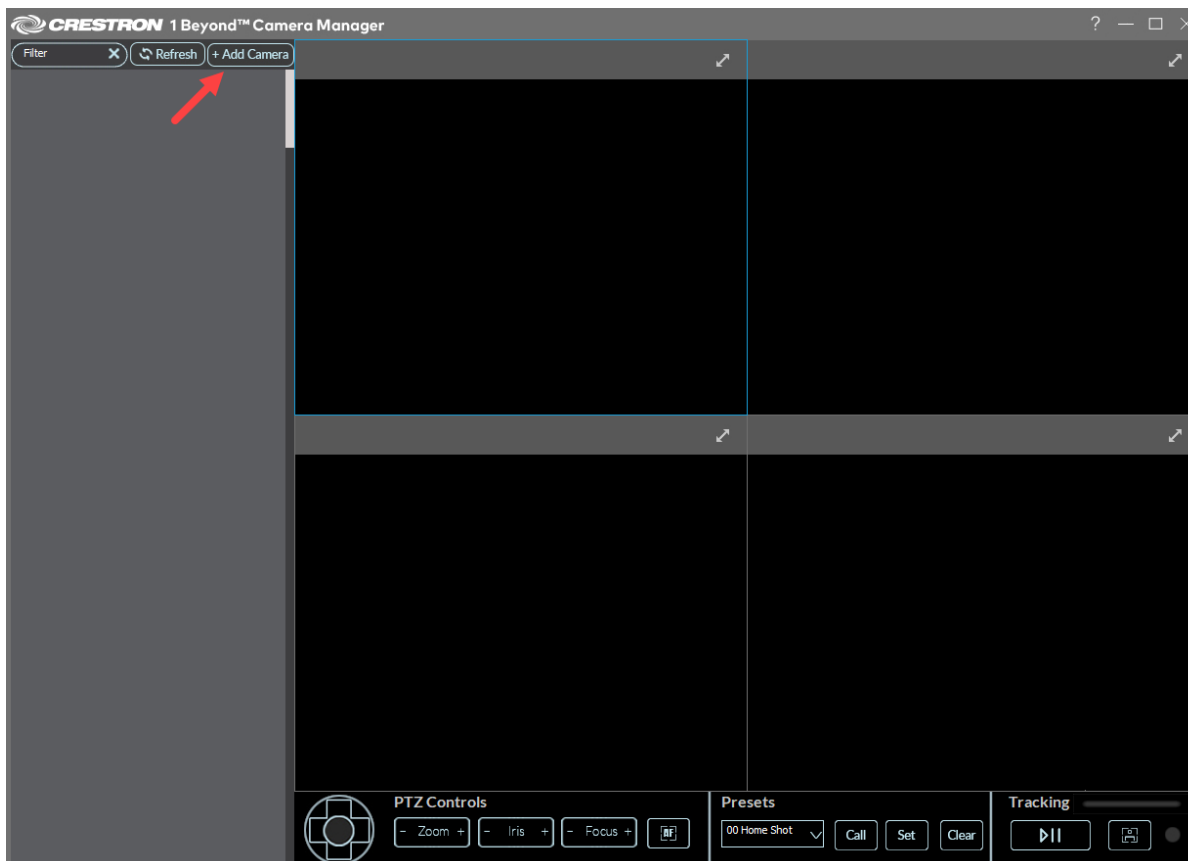

The **ADD CAMERA** window is displayed.

Add Camera Window

ADD CAMERA

Device Name IP Address App Port Username Password

5000 admin

NETWORK SEARCH

Filter Search Network

No.	Device Name	IP Address	MAC Address	Model	Firmware
-----	-------------	------------	-------------	-------	----------

Add Camera

2. Select **Search Network** to search for cameras on the network. The desired camera must be on the same network as the computer running the software. Cameras appear in the camera list with their IP address, MAC address, model, device name and firmware version.

Search Network

ADD CAMERA

Device Name IP Address App Port Username Password

5000 admin

NETWORK SEARCH

Filter Search Network

No.	Device Name	IP Address	MAC Address	Model	Firmware
-----	-------------	------------	-------------	-------	----------

Add Camera

3. Select the desired camera in the camera list, then select **Add Camera** in the bottom right of the **ADD CAMERA** window.

Add Camera

The screenshot shows the 'ADD CAMERA' window with the following fields: Device Name (i20-00040510F9A7), IP Address (empty), App Port (5000), Username (admin), and Password (empty). Below these is a 'NETWORK SEARCH' section with a 'Filter' text field and a 'Search Network' button. A table lists search results with columns: No., Device Name, IP Address, MAC Address, Model, and Firmware. The first row is highlighted in blue. At the bottom right, there are 'Edit IP' and 'Add Camera' buttons, with a red arrow pointing to the 'Add Camera' button.

No.	Device Name	IP Address	MAC Address	Model	Firmware
001	i20-00040510F9A7		00:04:05:10:F9:A7	i20	1.0.24
002	i12-00040510CB14		00:04:05:10:CB:14	i12	1.0.24
003	i12-C4426820FFD7		C4:42:68:20:FF:D7	i12	1.0.24
004	i12-000405080AF0		00:04:05:08:0A:F0	i12	1.0.24

TIP: Use the filter text field to narrow network search results for cameras. Input a parameter (IP address, camera model, MAC address) of the desired camera into the field. The search results will show all cameras that match the input parameters.

Filter Text Field

The screenshot shows the 'ADD CAMERA' window with the 'Filter' text field in the 'NETWORK SEARCH' section highlighted with a red box. The text '00:04:05:08' is entered in the filter field. The table below shows search results for this filter, with one row visible: No. 001, Device Name i20-000405080ADF, IP Address (empty), MAC Address 00:04:05:08:0A:DF, Model i20, and Firmware 1.0.24.

No.	Device Name	IP Address	MAC Address	Model	Firmware
001	i20-000405080ADF		00:04:05:08:0A:DF	i20	1.0.24

When the camera connects to the host computer, the **Initial Setup** window is displayed.

Initial Setup

ADD CAMERA [Close]

Device Name: i12-000405080ADF | IP Address: 10.79.50.228 | App Port: 5000 | Username: admin | Password: []

NETWORK SEARCH

Filter: [] Initial Setup

No.	Device Name
001	i12-C4426820F1
002	i20-00040510F5
003	i12-00040510C1
004	i12-000405080A

New Password: []

Confirm Password: []

It is recommended to enable Auto-Update and NTP Server in Advanced Settings to ensure the camera receives new firmware upgrades.

[Apply] [Cancel]

[Edit IP] [Add Camera]

NOTE: A prompt is shown displaying "Unable to add camera. Please check network parameters". if the camera is unable to connect to the host computer. Verify that the camera's network parameters are correct under the **ADD CAMERA** banner.

Network Parameters

ADD CAMERA [Close]

Device Name: i20-000405080ADF | IP Address: [] | App Port: 5000 | Username: admin | Password: []

NETWORK SEARCH

Filter: [X] [Search Network]

No.	Device Name	IP Address	MAC Address	Model	Firmware
001	i20-000405080ADF		00:04:05:08:0A:DF	i20	1.0.24

[Edit IP] [Add Camera]

4. Enter a password for the camera into the **New Password** and **Confirm Password** fields, then select **Apply**.

Password Entry

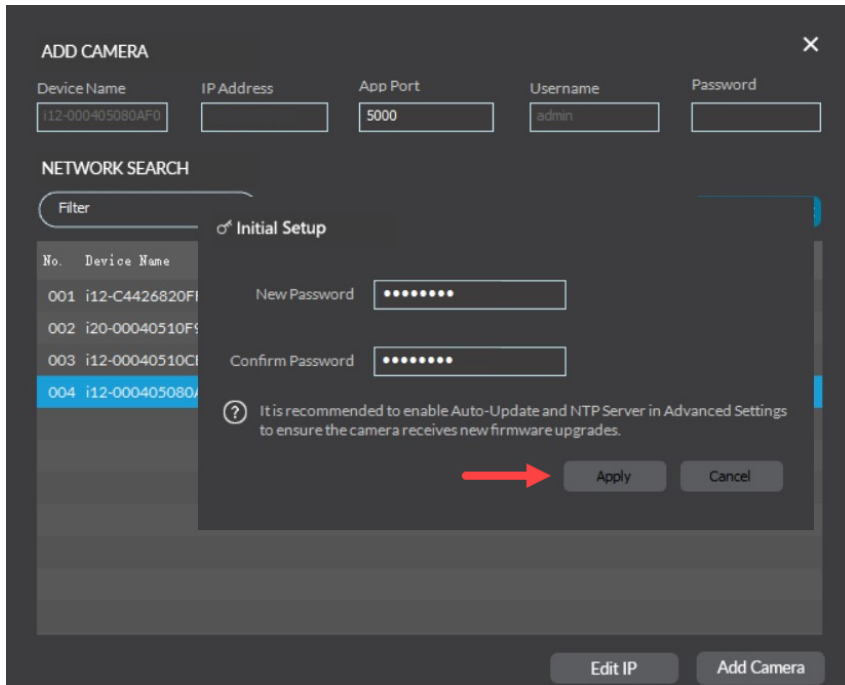

The screenshot shows a dark-themed 'ADD CAMERA' dialog box. At the top, there are input fields for 'Device Name' (i12-000405080AF0), 'IP Address', 'App Port' (5000), 'Username' (admin), and 'Password'. Below this is a 'NETWORK SEARCH' section with a 'Filter' input and a table of search results. The table has columns 'No.' and 'Device Name'. The fourth row is highlighted in blue: '004 i12-000405080'. To the right of the table is the 'Initial Setup' section, which contains 'New Password' and 'Confirm Password' fields, both filled with dots. Below these fields is a warning message: '? It is recommended to enable Auto-Update and NTP Server in Advanced Settings to ensure the camera receives new firmware upgrades.' At the bottom of the 'Initial Setup' section are 'Apply' and 'Cancel' buttons. A red arrow points to the 'Apply' button. At the very bottom of the dialog box are 'Edit IP' and 'Add Camera' buttons.

NOTE: The password entered for the camera also applies to RTSP and ONVIF connections for the camera.

5. Select **Add Camera**.

The camera is now available in the camera list.

Camera List

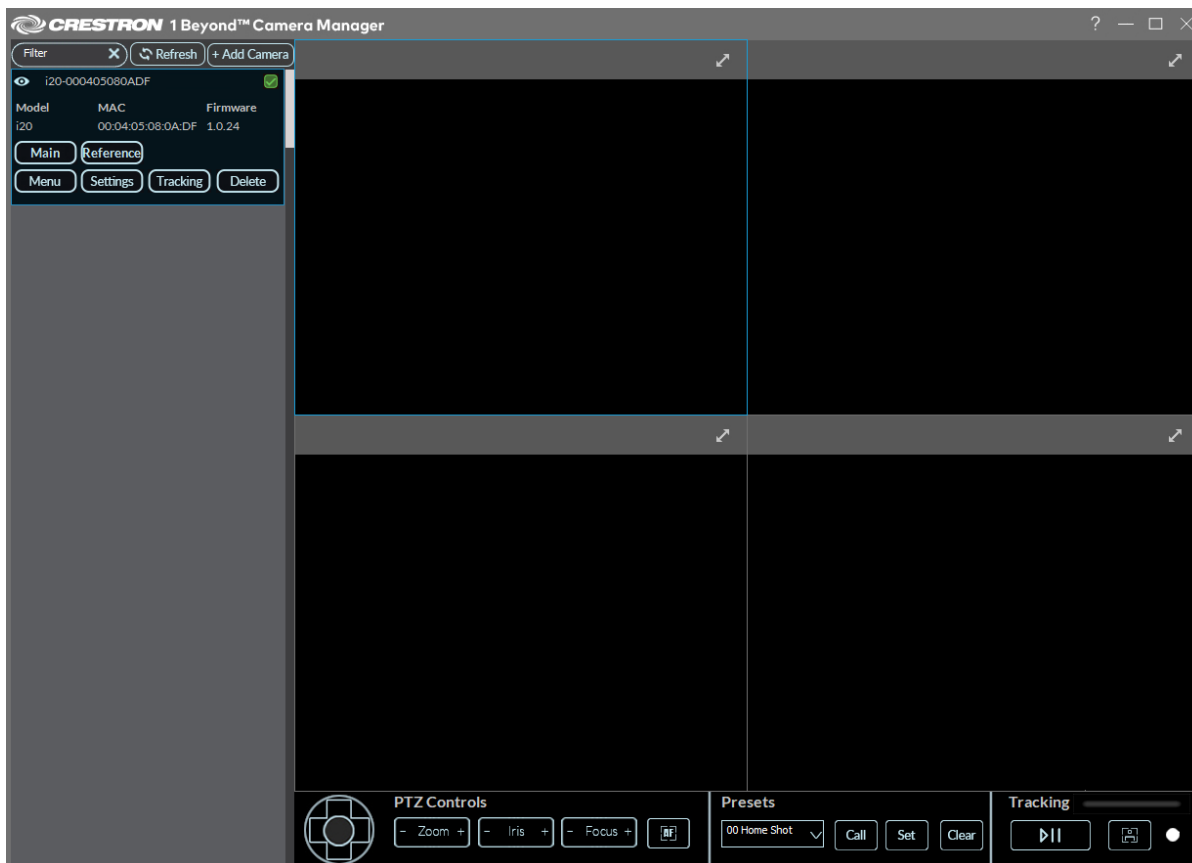

Add a Configured Camera

To add a camera that was previously configured in Crestron 1 Beyond Camera Manager 2 but is not currently displayed in the camera list:

1. Select **+ Add Camera** in the top left of the user interface.

+ Add Camera

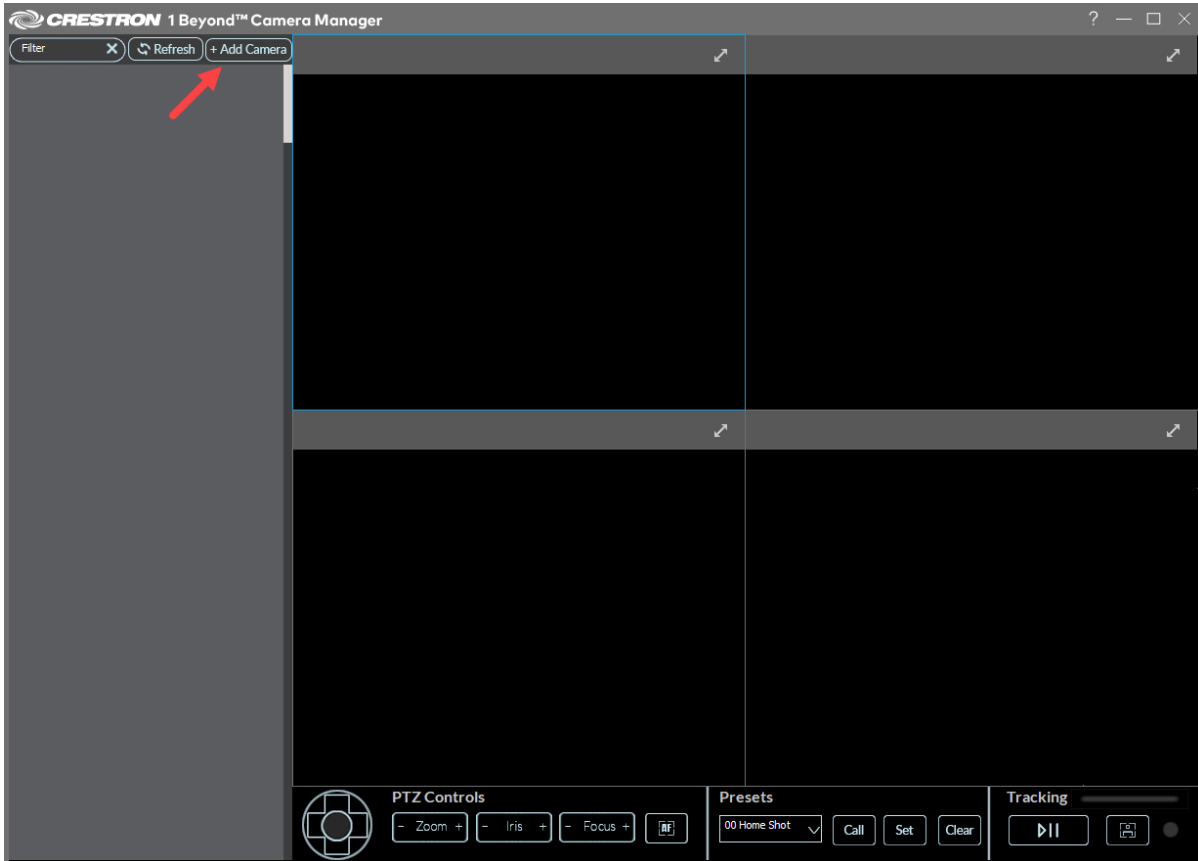

The **ADD CAMERA** window is displayed.

Add Camera Window

ADD CAMERA [Close]

Device Name: IP Address: App Port: Username: Password:

NETWORK SEARCH

Filter: [Close] Search Network

No.	Device Name	IP Address	MAC Address	Model	Firmware

[Add Camera]

2. Select **Search Network** to search for cameras on the network. The desired camera must be on the same network as the computer using the software.

Search Network

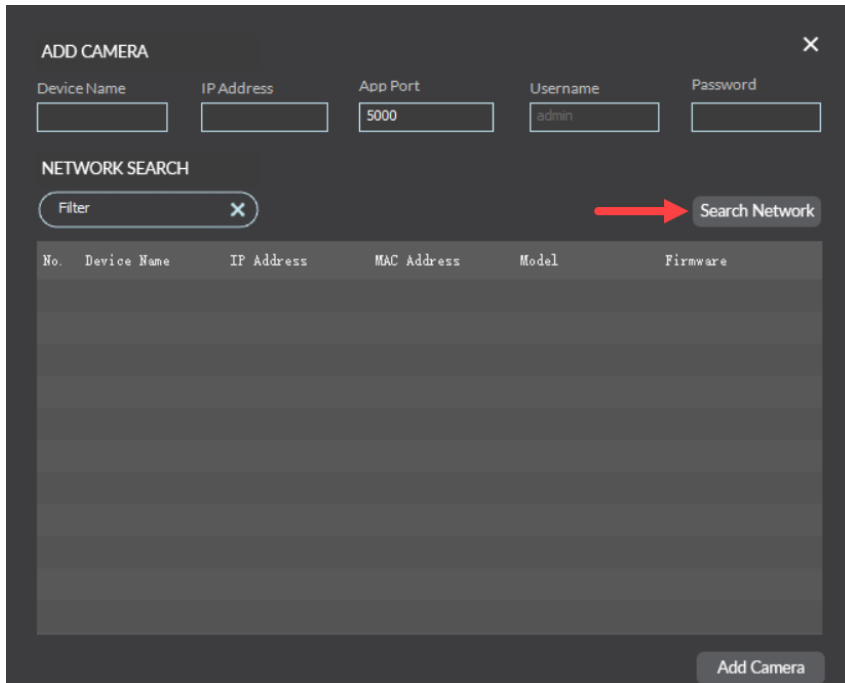

The screenshot shows the 'ADD CAMERA' dialog box with the following fields: Device Name, IP Address, App Port (5000), Username (admin), and Password. Below these is the 'NETWORK SEARCH' section, which includes a 'Filter' field and a 'Search Network' button. A red arrow points to the 'Search Network' button. At the bottom right of the dialog is an 'Add Camera' button.

TIP: Use the filter text field to narrow network search results for cameras. Input a parameter (IP address, camera model, MAC address) of the desired camera into the field. The search results show all cameras that match the input parameters.

Filter Text Field

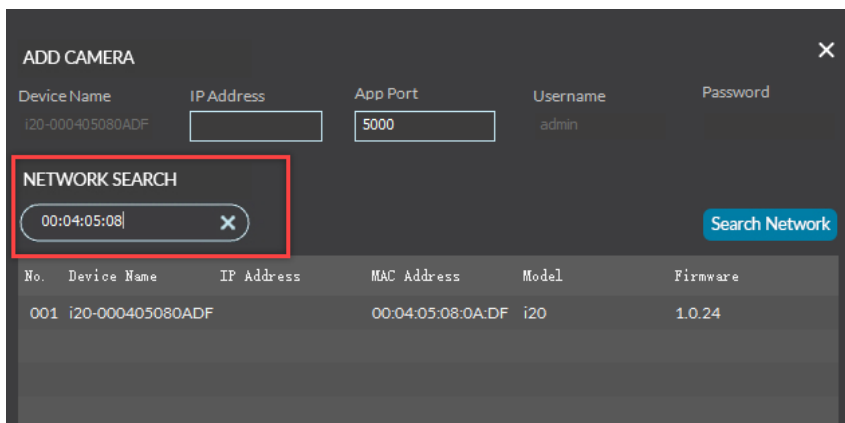

The screenshot shows the 'ADD CAMERA' dialog box with the following fields: Device Name (i20-000405080ADF), IP Address, App Port (5000), Username (admin), and Password. Below these is the 'NETWORK SEARCH' section, which includes a 'Filter' field containing '00:04:05:08' and a 'Search Network' button. The 'Filter' field is highlighted with a red box. The table below shows search results for the entered MAC address.

No.	Device Name	IP Address	MAC Address	Model	Firmware
001	i20-000405080ADF		00:04:05:08:0A:DF	i20	1.0.24

3. Cameras appear in the camera list with their IP address, MAC address, model, device name and firmware version. Select the desired camera in the camera list, then input the password of the camera into the **Password** text field.

Password Text Field

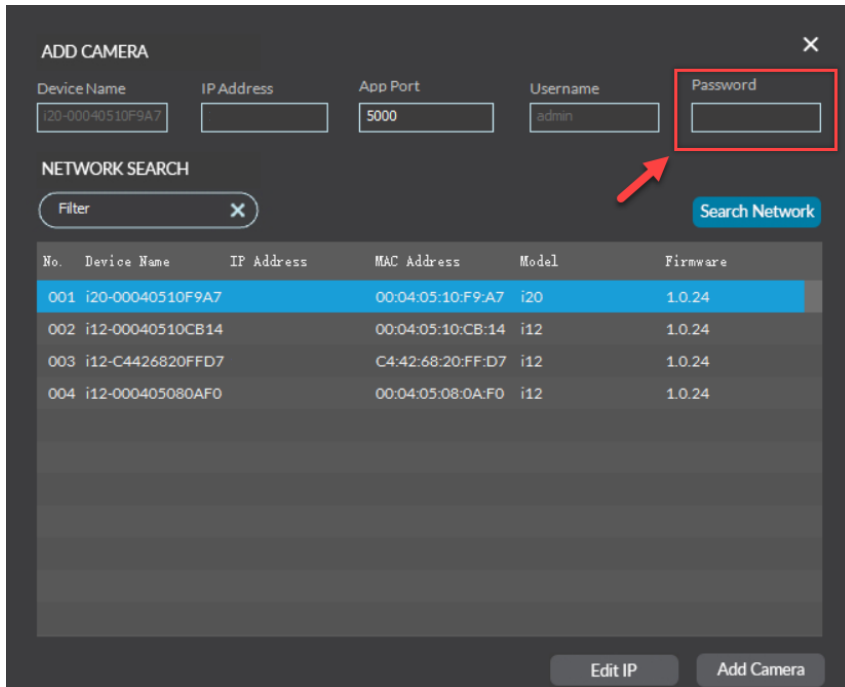

The screenshot shows a dark-themed 'ADD CAMERA' dialog box. At the top, there are five input fields: 'Device Name' (containing 'i20-00040510F9A7'), 'IP Address' (empty), 'App Port' (containing '5000'), 'Username' (containing 'admin'), and 'Password' (empty). The 'Password' field is highlighted with a red rectangular box. Below the form is a 'NETWORK SEARCH' section with a 'Filter' input field and a 'Search Network' button. A red arrow points from the 'Search Network' button towards the 'Password' field. At the bottom of the dialog, there are two buttons: 'Edit IP' and 'Add Camera'. Below the search section is a table with the following data:

No.	Device Name	IP Address	MAC Address	Model	Firmware
001	i20-00040510F9A7		00:04:05:10:F9:A7	i20	1.0.24
002	i12-00040510CB14		00:04:05:10:CB:14	i12	1.0.24
003	i12-C4426820FFD7		C4:42:68:20:FF:D7	i12	1.0.24
004	i12-000405080AF0		00:04:05:08:0A:F0	i12	1.0.24

4. Select **Add Camera** in the bottom right of the **ADD CAMERA** window.

Add Camera Window

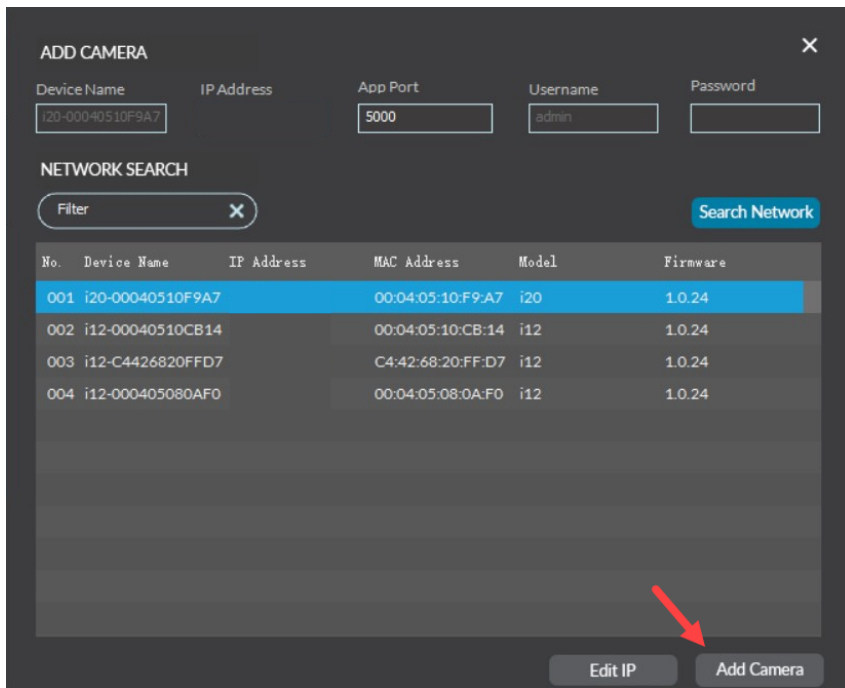

The screenshot shows the 'ADD CAMERA' window with the following fields and controls:

- Device Name: i20-00040510F9A7
- IP Address: (empty)
- App Port: 5000
- Username: admin
- Password: (empty)

Below the fields is a 'NETWORK SEARCH' section with a 'Filter' button and a 'Search Network' button.

No.	Device Name	IP Address	MAC Address	Model	Firmware
001	i20-00040510F9A7		00:04:05:10:F9:A7	i20	1.0.24
002	i12-00040510CB14		00:04:05:10:CB:14	i12	1.0.24
003	i12-C4426820FFD7		C4:42:68:20:FF:D7	i12	1.0.24
004	i12-000405080AF0		00:04:05:08:0A:F0	i12	1.0.24

At the bottom right, there are two buttons: 'Edit IP' and 'Add Camera'. A red arrow points to the 'Add Camera' button.

NOTE: The software shows a prompt indicating that the camera could not connect if the password for the camera is incorrect.

The camera is now available in the camera list.

Camera list

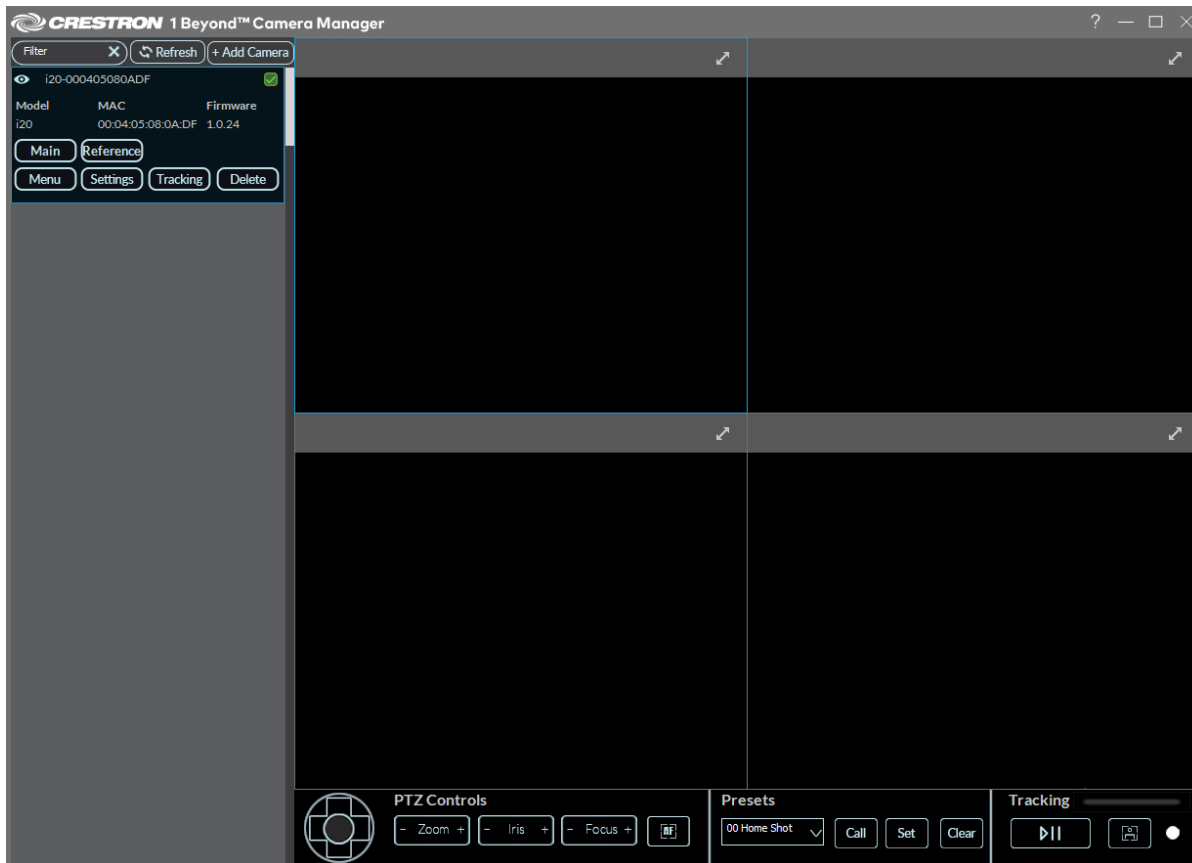

Manually Add a Camera

A camera can be added manually to the camera list by entering its network parameters within the **ADD CAMERA** menu.

To add a camera to the camera list manually:

1. Enter the camera's network information (**IP Address**, **App Port**, and **Password** if applicable) into the text fields below the **ADD CAMERA** banner.

Network Parameters

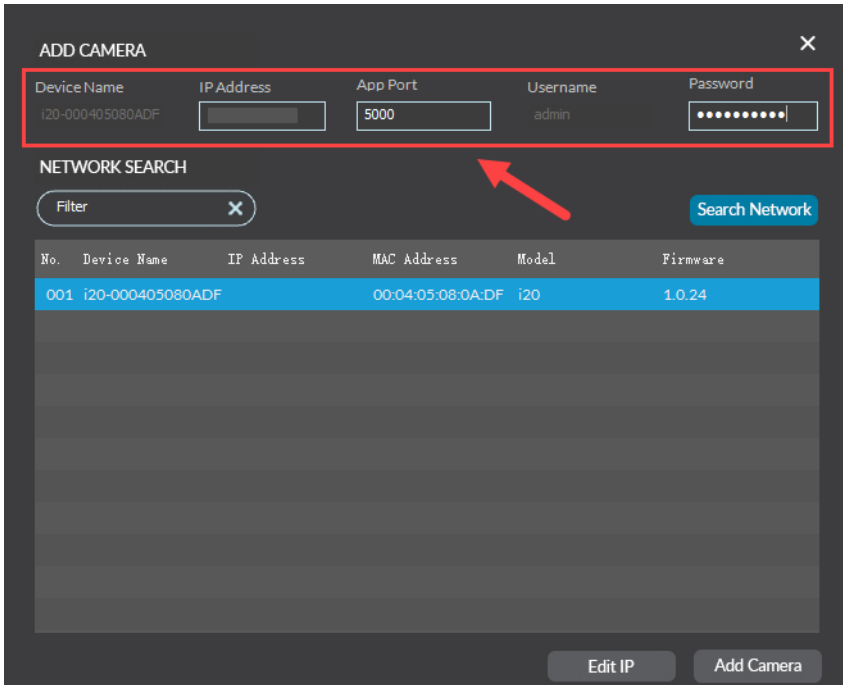

The screenshot shows the 'ADD CAMERA' dialog box with the following fields and values:

Device Name	IP Address	App Port	Username	Password
i20-000405080ADF		5000	admin	••••••••

Below the fields is a 'NETWORK SEARCH' section with a 'Filter' input, a 'Search Network' button, and a table of results:

No.	Device Name	IP Address	MAC Address	Model	Firmware
001	i20-000405080ADF		00:04:05:08:0A:DF	i20	1.0.24

At the bottom right, there are 'Edit IP' and 'Add Camera' buttons. A red arrow points to the 'Search Network' button.

2. Select **Add Camera** in the bottom right of the **ADD CAMERA** window.

Add Camera

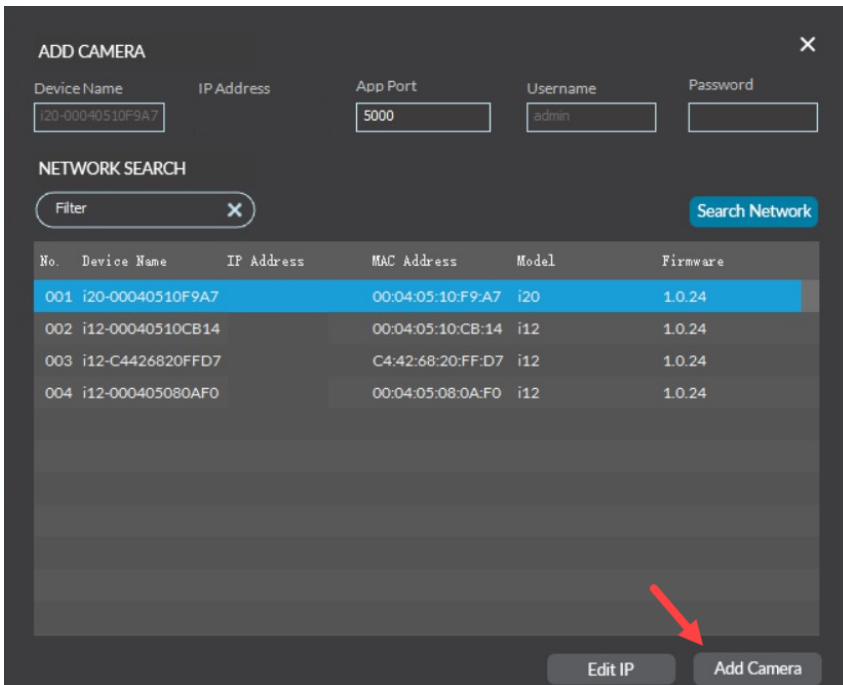

The screenshot shows the 'ADD CAMERA' dialog box with the following fields and values:

Device Name	IP Address	App Port	Username	Password
i20-00040510F9A7		5000	admin	

Below the fields is a 'NETWORK SEARCH' section with a 'Filter' input, a 'Search Network' button, and a table of results:

No.	Device Name	IP Address	MAC Address	Model	Firmware
001	i20-00040510F9A7		00:04:05:10:F9:A7	i20	1.0.24
002	i12-00040510CB14		00:04:05:10:CB:14	i12	1.0.24
003	i12-C4426820FFD7		C4:42:68:20:FF:D7	i12	1.0.24
004	i12-000405080AF0		00:04:05:08:0A:F0	i12	1.0.24

At the bottom right, there are 'Edit IP' and 'Add Camera' buttons. A red arrow points to the 'Add Camera' button.

The camera is now added to the camera list.

Edit IP

The **Edit IP** button in the **ADD CAMERA** window allows for the selected camera to have its IP settings changed. Select a camera in the camera list, then select **Edit IP** to open the **Edit IP Settings** window.

Edit IP Settings

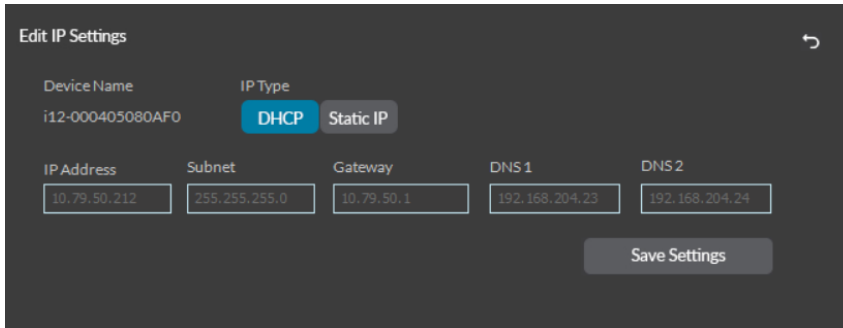

The screenshot shows the 'Edit IP Settings' window. At the top left is the title 'Edit IP Settings' and a back arrow icon. Below the title, there are two sections: 'Device Name' with the value 'i12-000405080AF0' and 'IP Type' with two buttons: 'DHCP' (highlighted in blue) and 'Static IP'. Below these are five input fields: 'IP Address' (10.79.50.212), 'Subnet' (255.255.255.0), 'Gateway' (10.79.50.1), 'DNS 1' (192.168.204.23), and 'DNS 2' (192.168.204.24). At the bottom right is a 'Save Settings' button.

By default, cameras are set to DHCP. Select **Static IP** under the IP Type header to enter network settings manually.

Edit Static IP

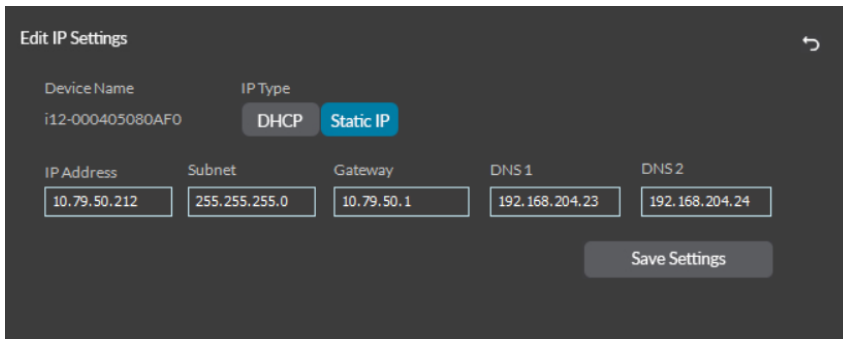

The screenshot shows the 'Edit IP Settings' window. At the top left is the title 'Edit IP Settings' and a back arrow icon. Below the title, there are two sections: 'Device Name' with the value 'i12-000405080AF0' and 'IP Type' with two buttons: 'DHCP' and 'Static IP' (highlighted in blue). Below these are five input fields: 'IP Address' (10.79.50.212), 'Subnet' (255.255.255.0), 'Gateway' (10.79.50.1), 'DNS 1' (192.168.204.23), and 'DNS 2' (192.168.204.24). At the bottom right is a 'Save Settings' button.

Select **Save Settings** to confirm network changes to the camera.

Delete Camera

To delete a camera from the camera list:

1. Select **Delete** on the desired camera in the camera list.

Delete Camera

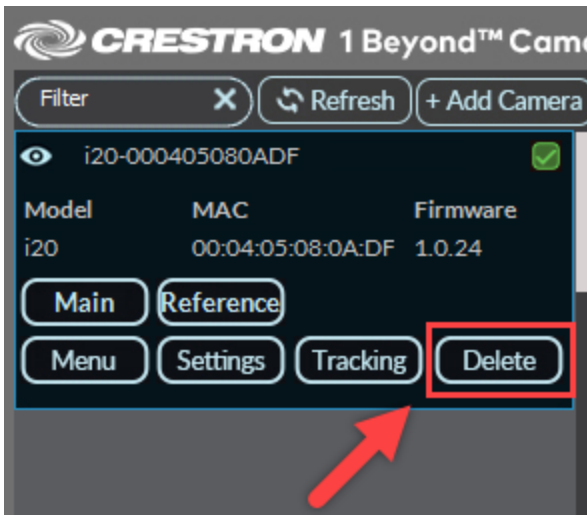

A window prompt is displayed stating "The following action will delete the camera. Are you sure you want to proceed?".

Window Prompt

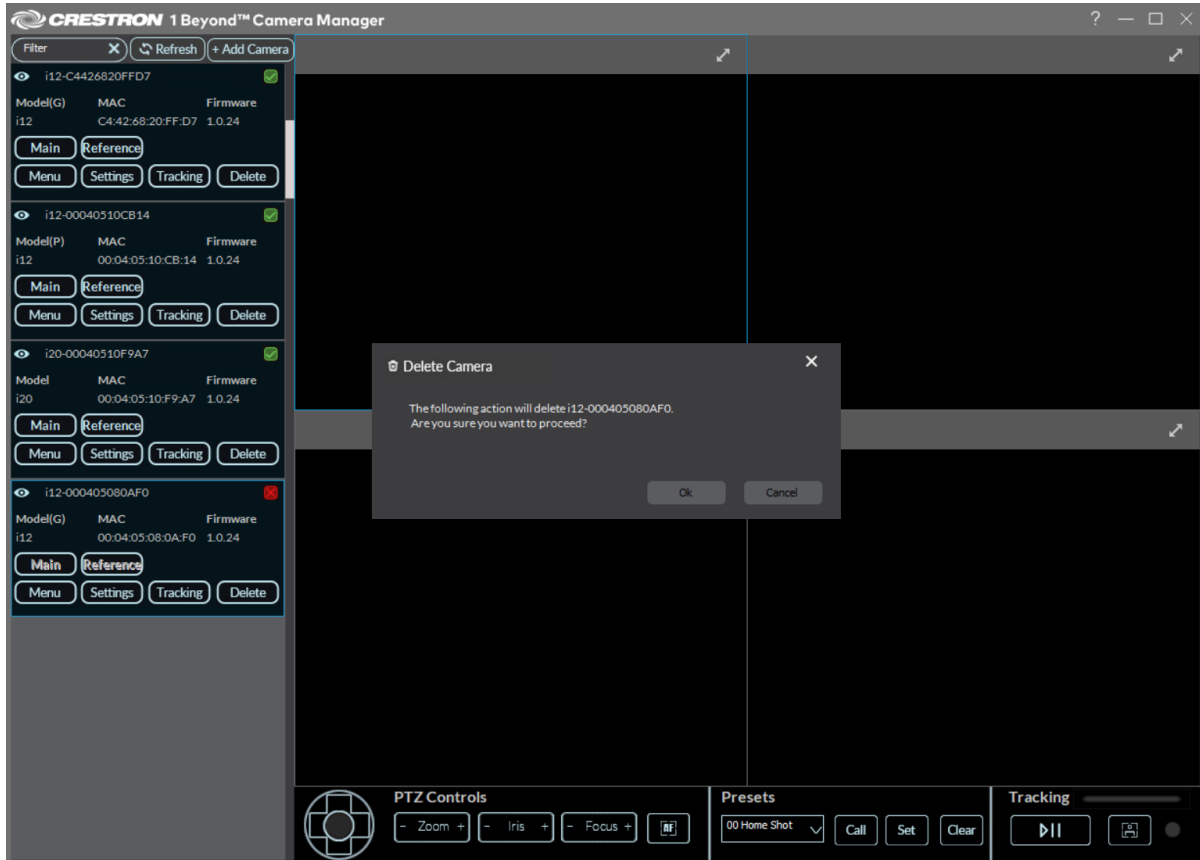

2. Select **Ok**.

The camera is now deleted from the software. To add the camera back to the software, refer to [Add a Configured Camera on page 123](#).

Delete All Cameras

To delete all cameras from the camera list, right click on the camera list. Then, select either **Clear All Cameras** to remove all cameras from the camera list, or select **Clear Offline Cameras** to remove just inactive cameras from the camera list.

Clear All Cameras

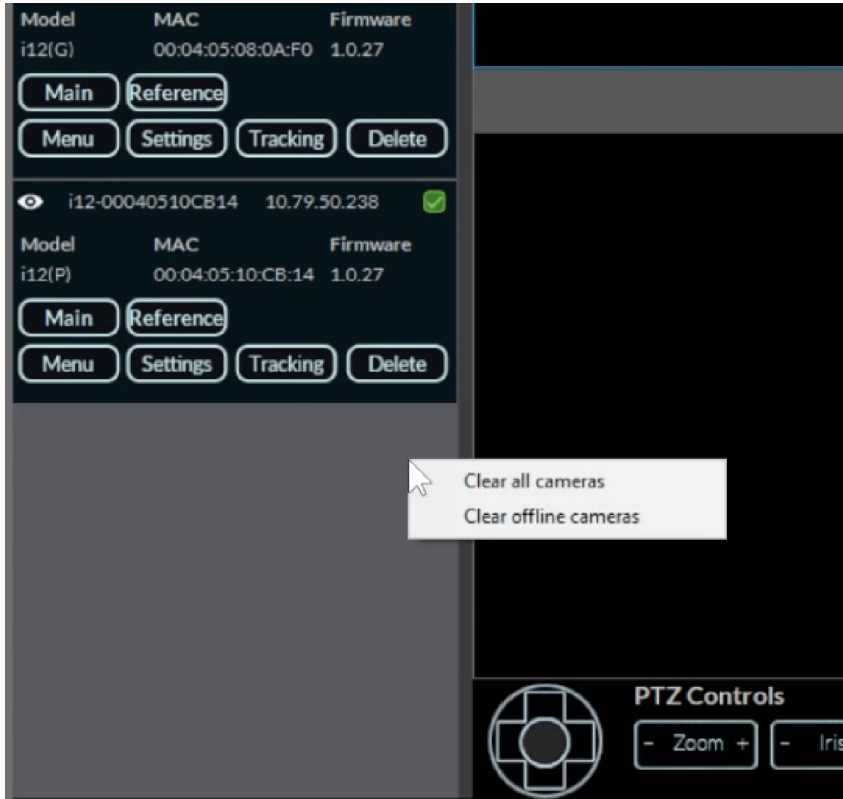

The cameras are now deleted from the software. To add cameras back to the software, refer to [Add a Configured Camera on page 123](#).

Identify Cameras

Once cameras are added to the software, they can be identified by having their light bar flash for 10 seconds. To have the respective camera's light bar flash, select the eyeball symbol on the top left of the desired camera in the camera list.

Identify Camera

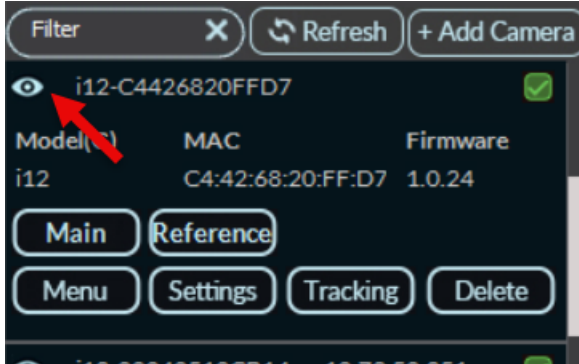

Set a Static IP Address

Crestron 1 Beyond cameras ship with DHCP turned on by default. The camera should be set to a static IP address for communications over the network.

To set a static IP address for a camera:

1. Select **Settings** on the desired camera in the camera list to open the **Advanced Settings** menu.

Settings Select

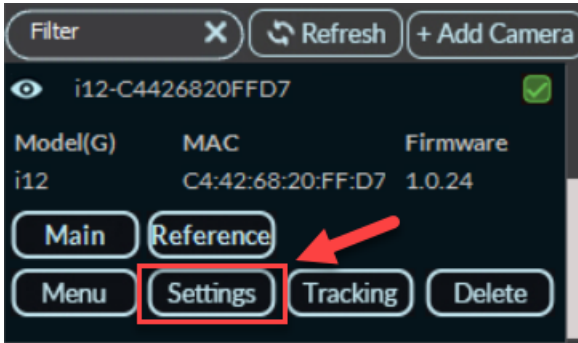

The **Advanced Settings** menu is displayed.

Advanced Settings Menu

The screenshot shows the 'Advanced Settings' menu with a dark background and white text. At the top, there are four tabs: 'Protocol' (selected), 'Network', 'Upgrade', and 'User'. The 'Protocol' tab is active, showing two main sections: 'Streaming' and 'Control'. The 'Streaming' section includes: 'Main Stream' (dropdown menu), 'Resolution' (dropdown menu set to '1080P'), 'Bitrate Type' (radio buttons for 'VBR' and 'CBR', with 'CBR' selected), 'Max Bitrate' (text input field set to '6000'), 'Frame Rate' (dropdown menu set to '30'), 'Key Frame Interval' (text input field set to '30'), 'Encoding Type' (dropdown menu set to 'H264'), and 'Encoding Profile' (dropdown menu set to 'High'). The 'Control' section includes: 'Enable' and 'Disable' buttons (with 'Enable' selected), 'Protocol Type' (dropdown menu set to 'TCP'), 'Device Mode' (radio buttons for 'Server' and 'Client', with 'Server' selected), 'Server IP Address' (text input field set to '0.0.0.0'), and 'Control Port' (text input field set to '5500'). Below the 'Control' section is the 'NDI' section with 'Enable' and 'Disable' buttons (with 'Enable' selected). To the right of the 'Control' section, under the 'User' tab, are three buttons: 'Reboot', 'Reset', and 'Reboot All Cameras'. At the bottom right of the menu is a 'Save Settings' button. A close button (X) is located in the top right corner.

2. Select the **Network** tab on the top of the **Advanced Settings** menu to access the **Network** menu.

Network Menu

Advanced Settings

Protocol **Network** Upgrade User

IP Type

IP Address

Mask

Gateway

DNS 1

DNS 2

NTP 21:04

NTP Server

Time Zone Offset

Auto-Update

Manifest URL

Auto-Update Time

3. Select the **IP Type** drop-down menu, then select **Static IP**.
4. Use the **IP Address** text field to enter a static IP address for the camera.
5. Select **Save Settings** to save the static IP address for the camera.

The camera is now set to a static IP address.

NOTE: Cameras can also be set to a static IP address in the **ADD CAMERA** window. For more information on setting a static IP via the **ADD CAMERA** window, refer to [Edit IP on page 130](#)

Update Firmware

Once the Crestron 1 Beyond camera is added to the Crestron 1 Beyond Camera Manager 2 software, the camera should be updated to the latest firmware. For more information on adding a camera to the software, refer to [Add Cameras on page 114](#).

To update the firmware of the camera:

1. Select **Settings** on the desired camera in the camera list to open the **Advanced Settings** menu.

Settings Select

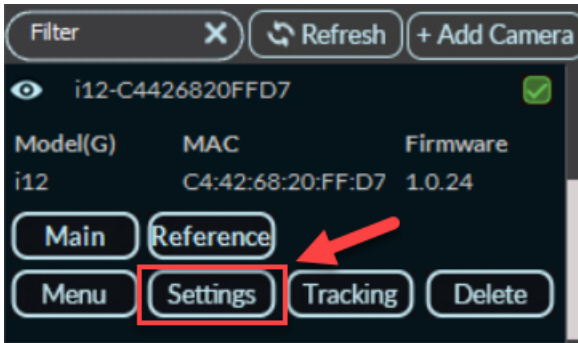

The **Advanced Settings** menu is displayed.

Advanced Settings Menu

The screenshot shows the 'Advanced Settings' menu with a dark background and white text. At the top, there are four tabs: 'Protocol' (selected), 'Network', 'Upgrade', and 'User'. The 'Protocol' tab is active, displaying two columns of settings: 'Streaming' and 'Control'. The 'Streaming' column includes: 'Main Stream' (dropdown menu), 'Resolution' (dropdown menu set to '1080P'), 'Bitrate Type' (radio buttons for 'VBR' and 'CBR', with 'CBR' selected), 'Max Bitrate' (text input field with '6000'), 'Frame Rate' (dropdown menu set to '30'), 'Key Frame Interval' (text input field with '30'), 'Encoding Type' (dropdown menu set to 'H264'), and 'Encoding Profile' (dropdown menu set to 'High'). The 'Control' column includes: 'Enable' and 'Disable' buttons (with 'Enable' selected), 'Protocol Type' (dropdown menu set to 'TCP'), 'Device Mode' (radio buttons for 'Server' and 'Client', with 'Server' selected), 'Server IP Address' (text input field with '0.0.0.0'), 'Control Port' (text input field with '5500'), and 'NDI' (radio buttons for 'Enable' and 'Disable', with 'Enable' selected). To the right of the 'Control' column, there are three buttons: 'Reboot', 'Reset', and 'Reboot All Cameras'. At the bottom right, there is a 'Save Settings' button. A close button (X) is located in the top right corner of the menu.

2. Select **Upgrade** on the top of the **Advanced Settings** menu to access the **Upgrade** menu.

Upgrade Menu

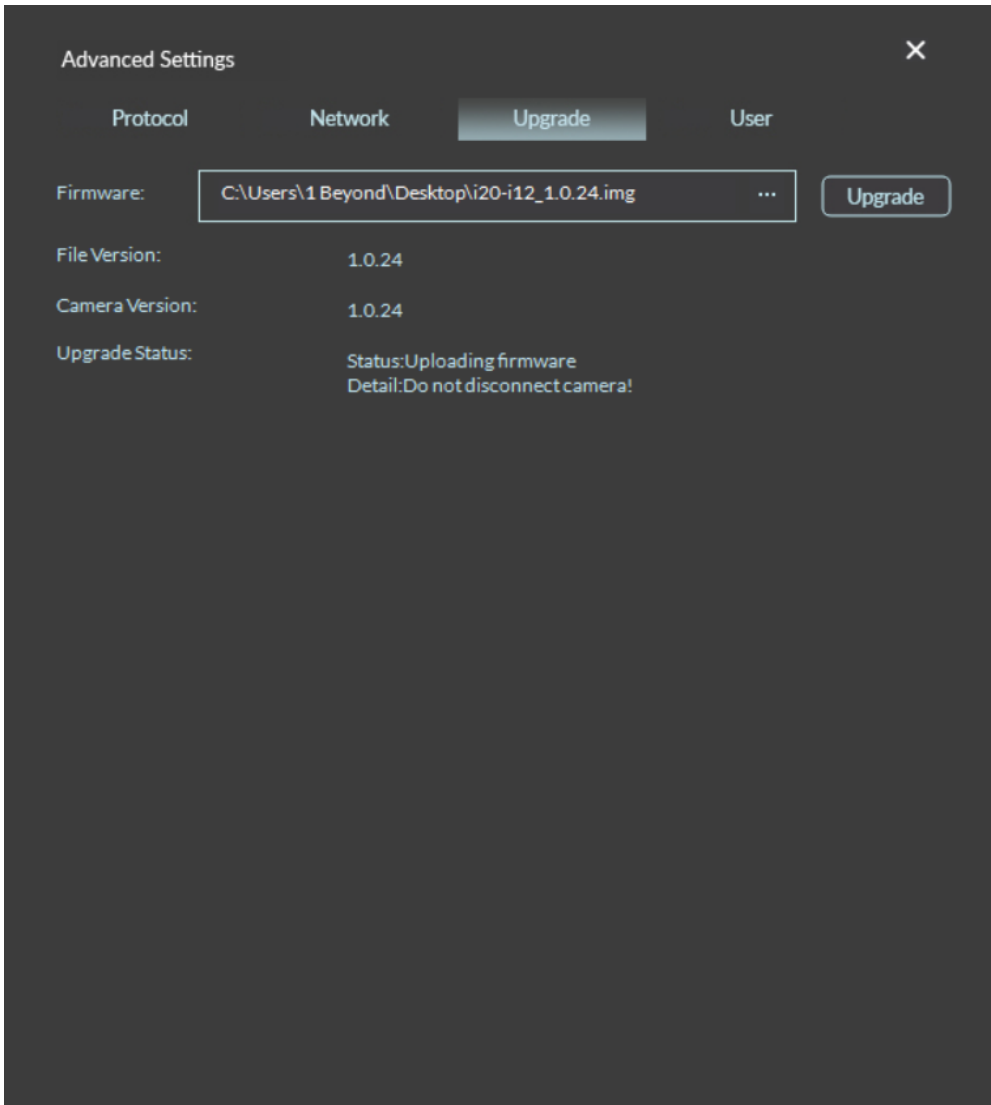

3. Download the respective camera firmware package from the [Crestron website](#).
4. Select the three dots icon on the right of the **Firmware** field. This opens a file explorer window on the computer.
5. Navigate to the firmware file on the computer. Select the firmware file and the camera then performs the firmware update.

NOTE: The firmware file must be extracted from the downloaded .zip file before updating the camera. Failure to do so causes the firmware file to not be discoverable by the software.

6. The firmware update status is displayed next to **Upgrade Status**. Wait for the **Upgrade Status** to display **Completed** before leaving this menu. Once **Completed** is shown, the firmware update is complete.

The camera is now updated to the latest firmware. To enable automatic updates for the camera, refer to [Network Settings on page 184](#).

Change the Camera Mode

IV-CAM-I12 and IV-CAM-I12D-B cameras can be set to their desired intelligent camera mode, and should be set once the camera is added to the Crestron 1 Beyond Camera Manager 2 software. For more information on adding a camera to the software, refer to [Add Cameras on page 114](#).

To change the camera mode:

1. Select the **Tracking** button in the camera list.

Tracking Button

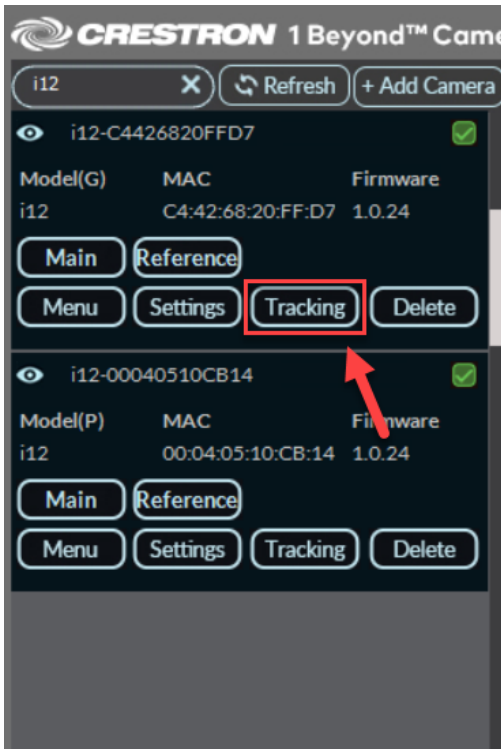

The Tracking Menu is displayed.

Tracking Menu

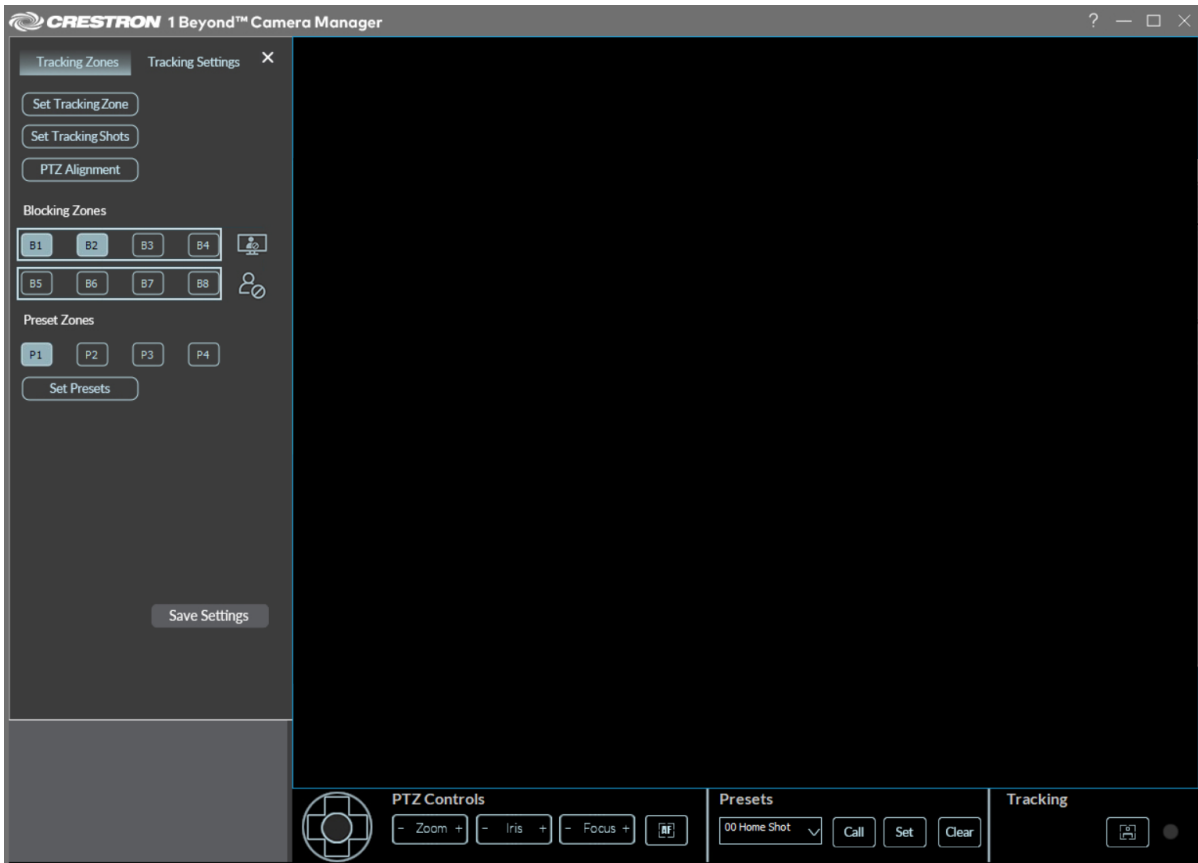

2. Select the **Tracking Settings** tab.

Select Tracking Settings

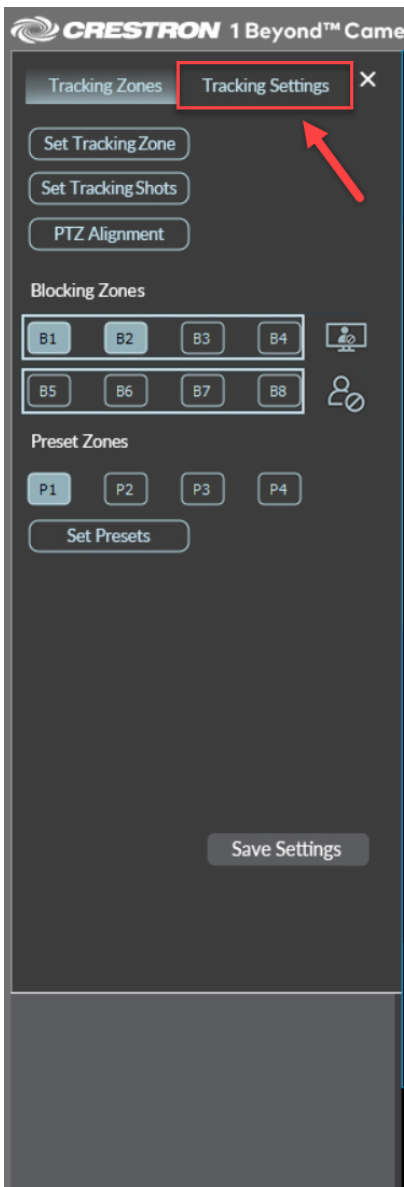

The **Tracking Settings** menu is displayed.

Tracking Settings Menu

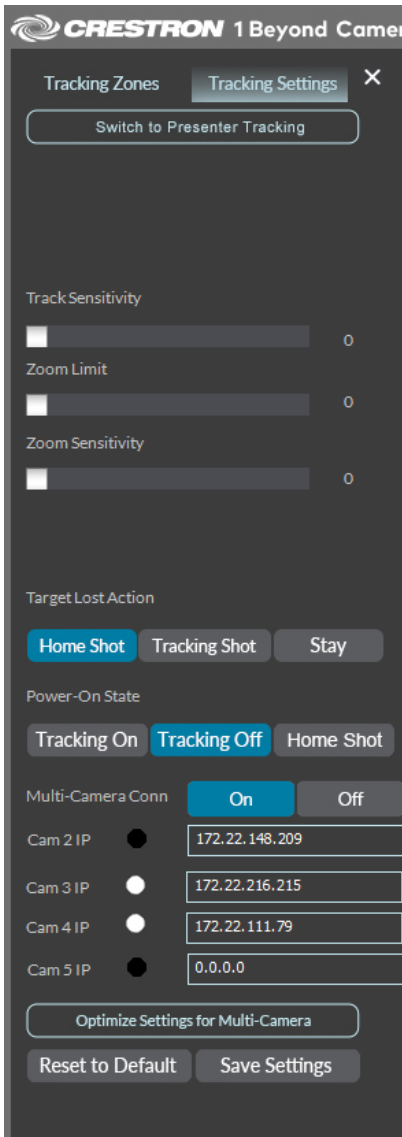

3. Select the button at the top of the Tracking Settings tab. Depending on the camera mode, it displays either **Switch to Presenter Tracking** or **Switch to Group Framing**.

NOTE: The image below displays the i12 camera in Group Framing mode.

Switch to Presenter Tracking

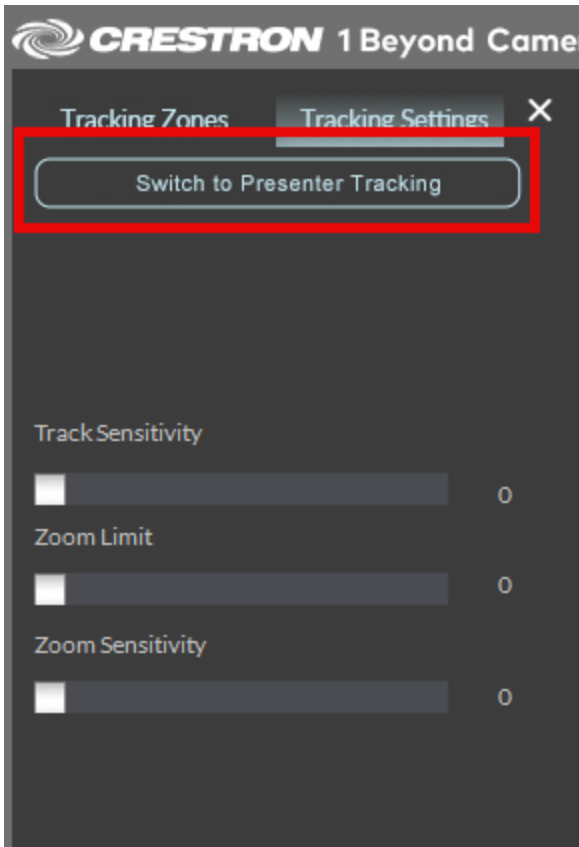

The camera is now set to the desired camera mode.

Device Configuration

Prior to configuration, ensure all necessary setup procedures were completed as described in [Initial Setup on page 112](#).

This section provides the following information:

- [Accessing Camera Feeds](#)
- [Camera Controls](#)
- [Reserved Presets](#)
- [On-Screen Display \(OSD\)](#)
- [Advanced Camera Settings](#)
- [Tracking Menu](#)

Accessing Camera Feeds

Both the main PTZ camera and wide-angle reference camera video feeds can be displayed in the user interface at the same time. Up to four different video feeds from other cameras can be displayed. Refer to the following sections for more information on accessing and viewing camera video feeds.

View the PTZ Camera Feed

To view the PTZ camera's video feed, select **Main** on the desired camera in the camera list.

Main Video Feed

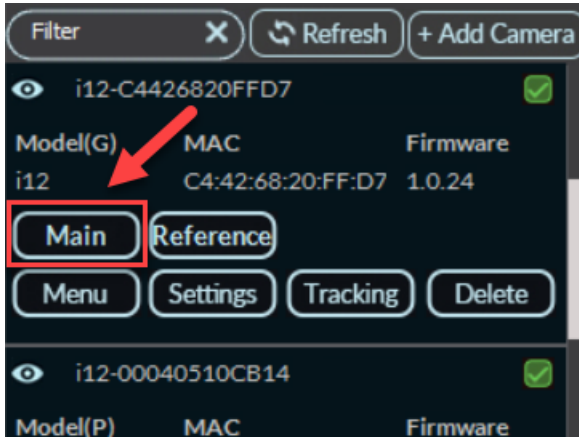

The main PTZ camera's feed is now displayed in the user interface.

Main Stream View

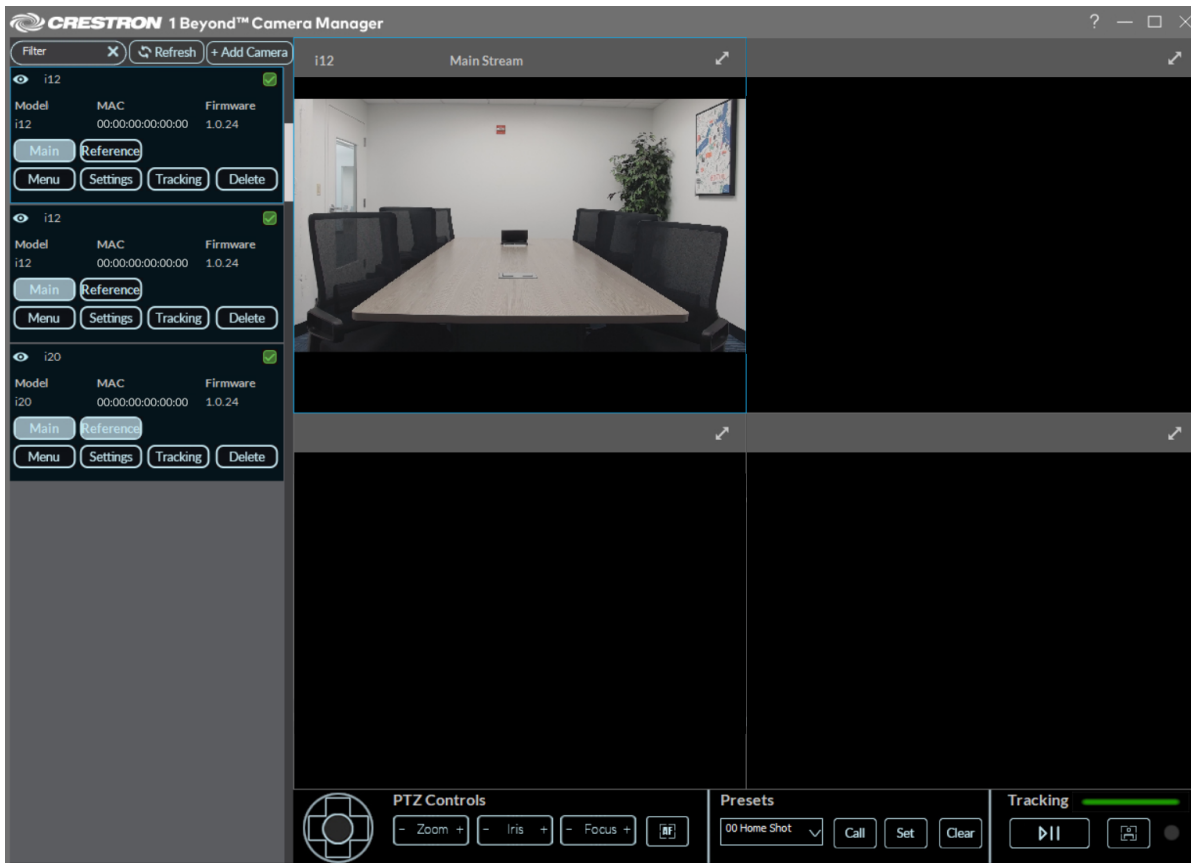

NOTE: If four camera feeds are displayed in the quad view, adding a new feed from the camera menu will replace the last added feed. To control the camera feed that is replaced, left click on the feed in the quad view before selecting a new feed.

View the PTZ 1 and PTZ 2 Camera Feeds (IV-CAM-I12D-B)

The IV-CAM-I12D-B has two PTZ cameras that are available to view. To view the PTZ camera video feeds, select **PTZ 1** or **PTZ 2** on the desired camera in the camera list.

PTZ 1 and PTZ 2 Feeds

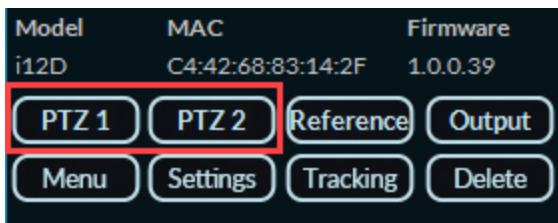

The selected PTZ camera's feed is now displayed in the user interface.

View the Output (IV-CAM-I12D-B)

The IV-CAM-I12D-B switches between its PTZ 1, PTZ 2, and reference camera video feeds during operation. To view the current output of the IV-CAM-I12D-B, select **Output** on the desired camera in the camera list.

NOTE: Conversation Mode and Picture-in-Picture (PIP) layouts are not visible on the Output via Camera Manager. These layouts are only available on the HDMI and USB streams of the camera. For more information about layouts, refer to [Speaker Tracking Settings on page 226](#).

Output Feed

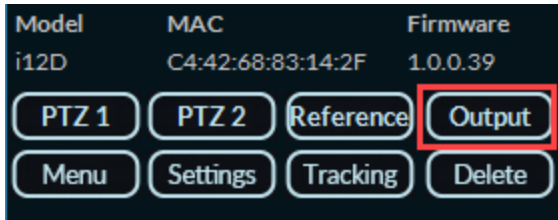

View the Wide-Angle Reference Camera Feed

To view the wide-angle reference camera's video feed, select **Reference** on the desired camera in the camera list.

Reference Video Feed

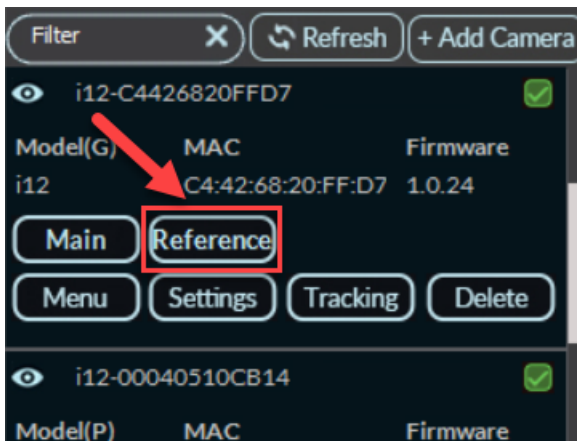

The wide-angle reference camera's feed is now displayed in the user interface.

Wide-Angle Reference Stream

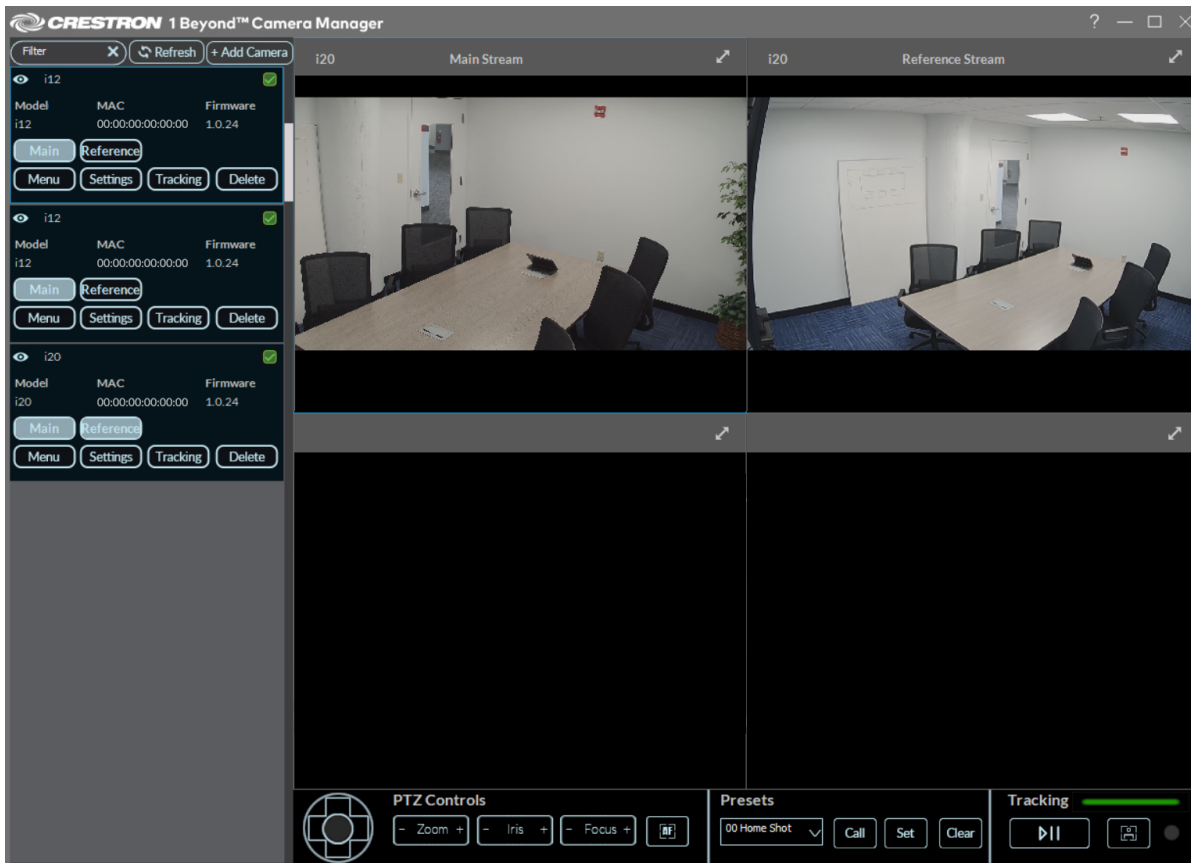

NOTE: If four camera feeds are displayed in the quad view, adding a new feed from the camera menu will replace the last added feed. To control the camera feed that is replaced, left click on the feed in the quad view before selecting a new feed

Closing Camera Feeds

To close a camera's video feed, right click the desired video feed and select **Close Stream**.

Close Stream

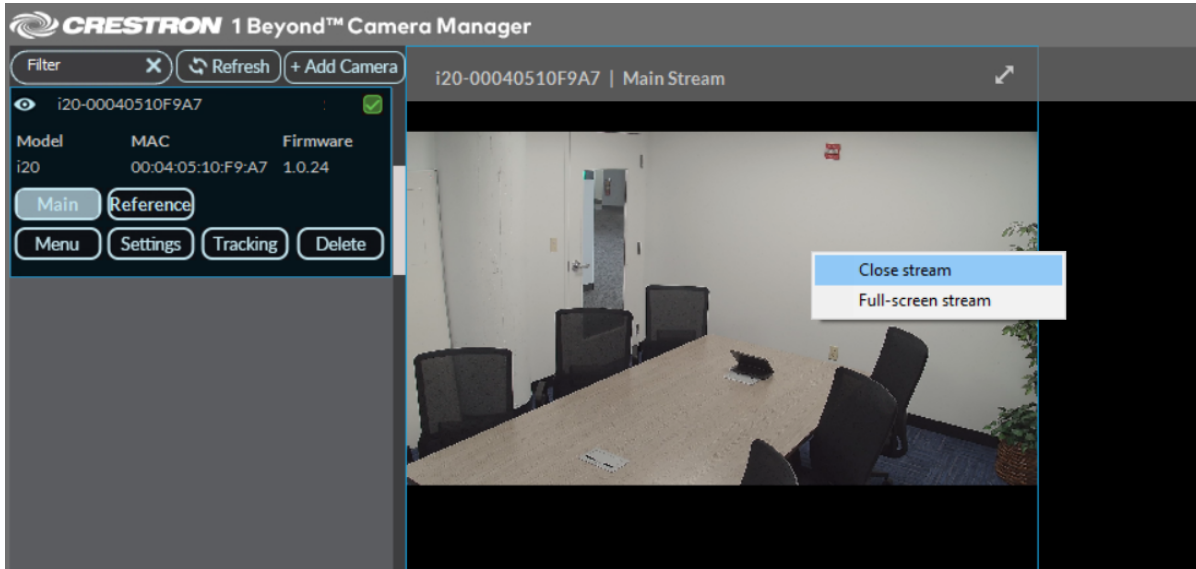

NOTE: The procedure above works on both the quad view and full screen video feeds.

Full Screen Close Stream

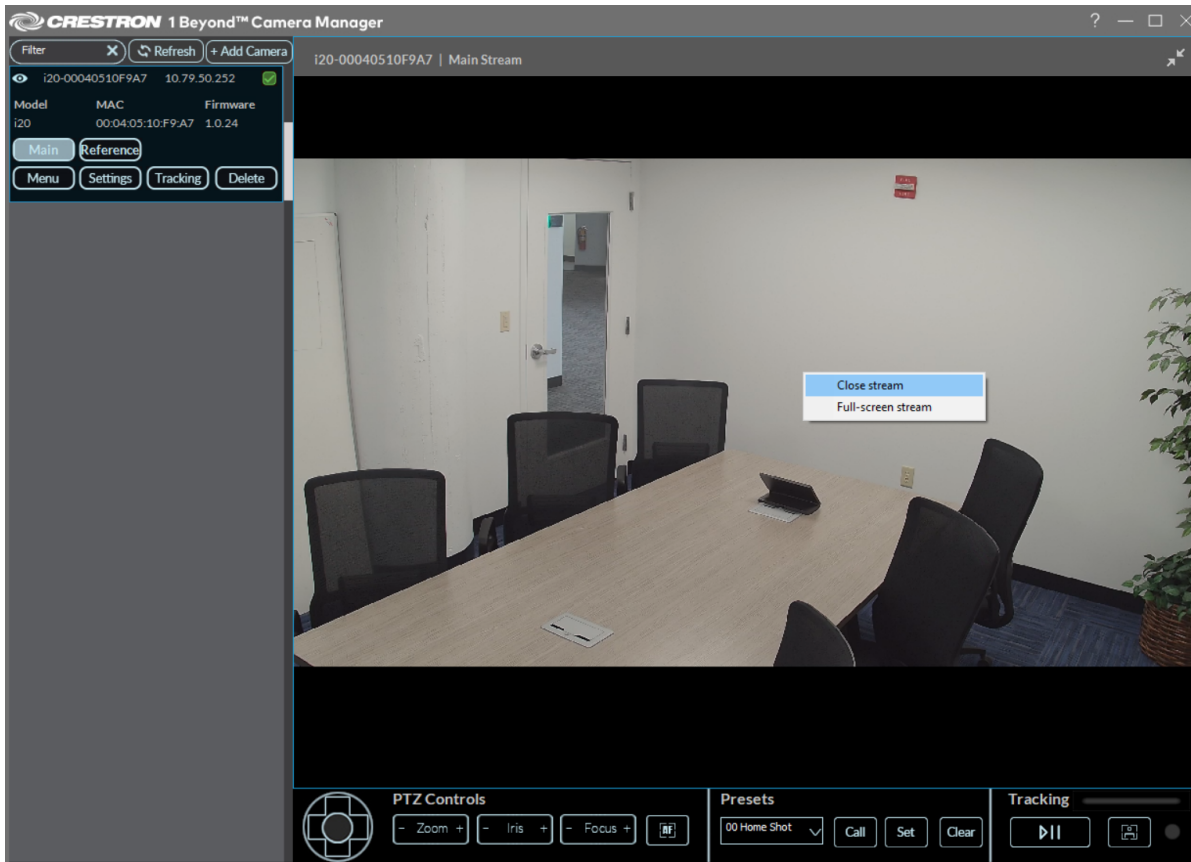

Alternatively, selecting the **Main** or **Reference** buttons closes the respective camera's video feed.

View the Full Screen Camera Feed

By default, the quad view is displayed in the user interface. To view a camera's video feed in full screen instead of quad view, select the double arrow icon in the top right corner of the respective video feed.

Double Arrow Icon

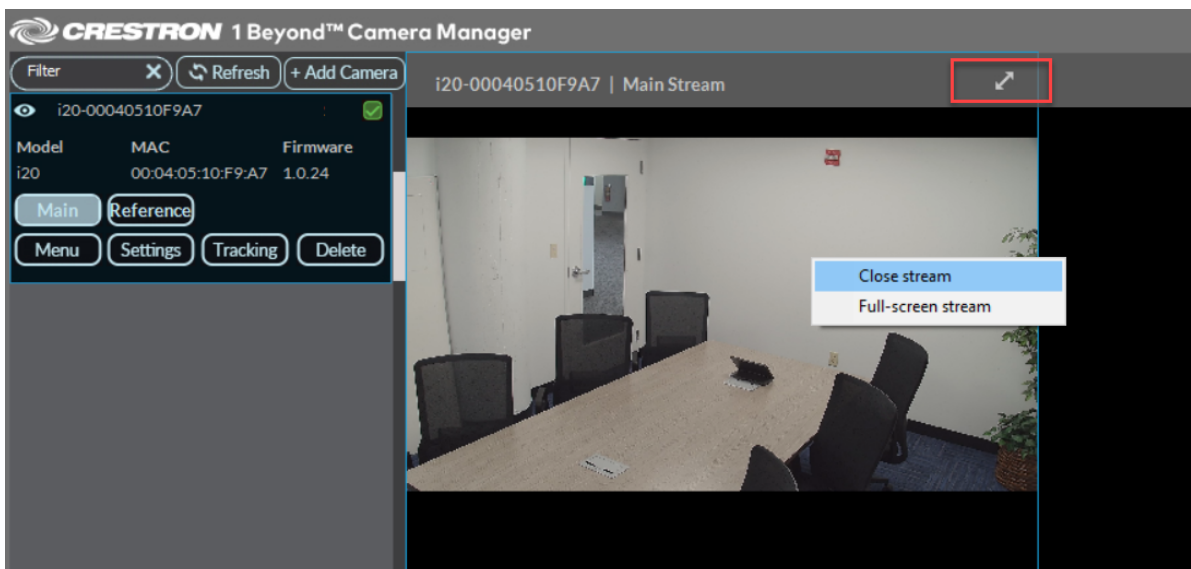

Alternatively, right click the desired video feed and select **Full-Screen Stream** to enter full screen borderless mode, hiding the user interface. Right click and select **Close Stream** to exit the full screen borderless mode.

Select Full-Screen Stream

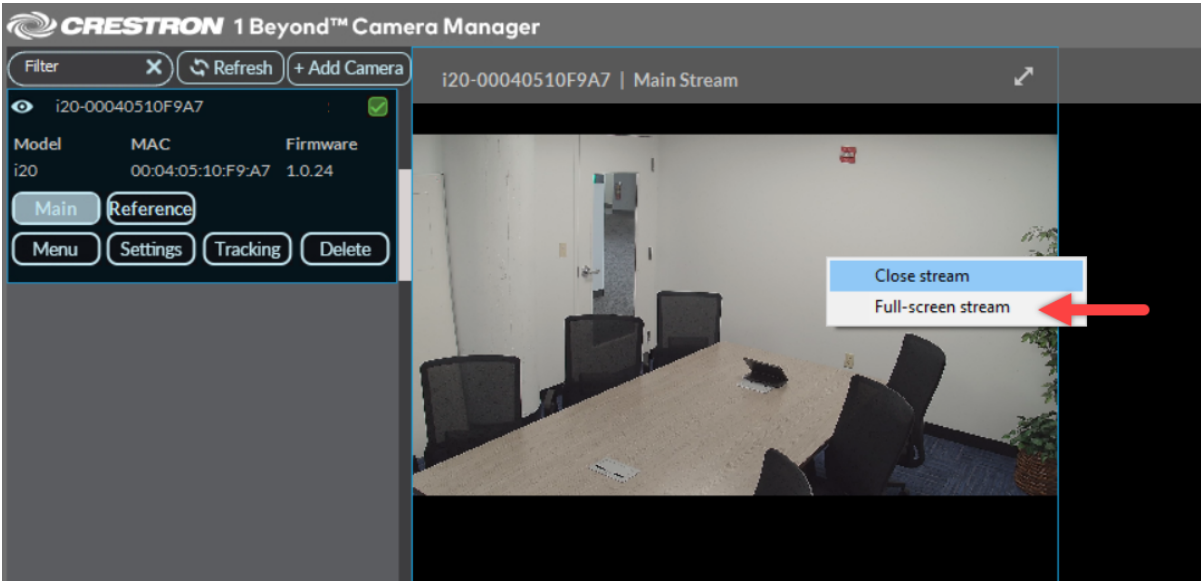

Camera Controls

Crestron 1 Beyond camera shots can be manually configured with the Crestron 1 Beyond Camera Manager 2 software. These controls are located at the bottom of the user interface.

Camera Settings

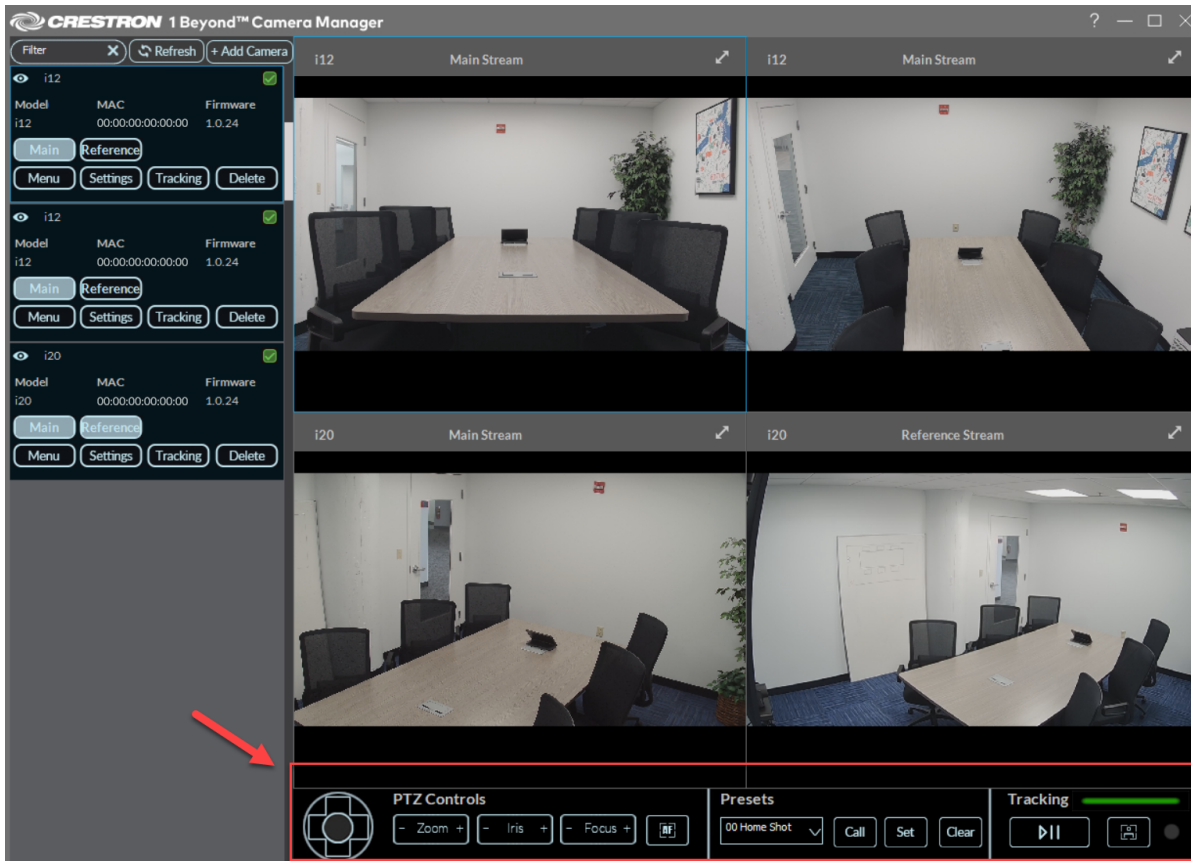

PTZ Controls

PTZ Controls allow for manual pan, tilt, zoom, iris, and focus controls of the PTZ camera.

PTZ Controls

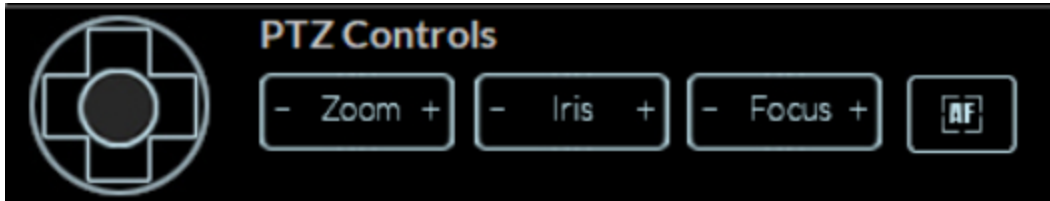

- **Navigation Pad:** Use the left and right buttons to pan the camera, and the up and down buttons to tilt the camera. The four corners on the navigation pad simultaneously pan and tilt the PTZ camera in the respective direction. The center button returns the camera to its center position.
- **- Zoom +:** Use the + and - buttons to zoom the PTZ camera shot in or out.
- **- Focus +:** Use the + and - buttons to increase and decrease the PTZ camera lens focus.
- **AF:** Use to auto focus the PTZ camera lens.

NOTE: Auto focus is only available when presenter tracking is disabled. When presenter tracking is enabled, the camera automatically focuses the camera lens. For more information about Presenter Tracking, refer to [Presenter Tracking Settings on page 222](#).

Presets

Presets are used to switch to specific camera shots when the preset is called. Presets must be **Set** before they can be called. Refer to the following information on setting and calling presets.

NOTE: There are reserved camera presets that cannot be overwritten. For more information, refer to [Reserved Presets on page 160](#).

Presets Settings

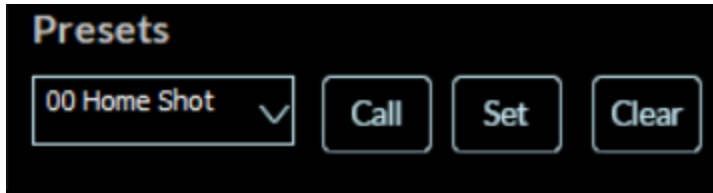

Open the **Presets** drop-down menu by selecting the down arrow to display all camera presets. Select the desired preset to set it as the active preset. The **Call**, **Set**, and **Clear** controls will be applied to the active preset.

NOTE: **Preset 0** and **Preset 1** are reserved as the **Home Shot** and **Tracking Shot**. For more information, refer to [Tracking Menu on page 191](#).

- **Set:** Sets the current camera shot for the active preset. When **Call** is selected, the camera feed switches to the camera shot that was configured with **Set**. Selecting **Set** will override the previous camera shot associated with the preset.

TIP: Use the PTZ Controls to manually create a camera shot for the preset. For more information, refer to [PTZ Controls on page 157](#).

- **Call:** Switch the camera shot to the preset. If the preset has not been set first, **Call** does not switch the camera shot.
- **Clear:** Delete the camera shot set to the preset. The preset is now empty and can be **Set** for another camera shot if desired.



Tracking

NOTE: The **Tracking** settings are only available for the IV-CAM-I12, IV-CAM-I20, and IV-CAM-I12D-B cameras.

The **Tracking** settings enable or disable the camera's intelligent functions (Group Framing and Presenter Tracking), display the current intelligent function status, and enable or disable debug mode for the camera.

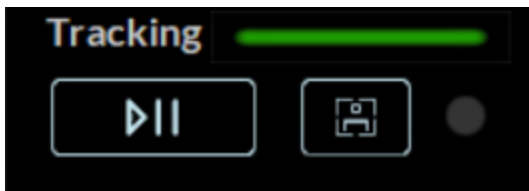
Tracking Settings



- **Tracking** color bar: This shows the intelligent function status of the camera.
 - Green indicates that the intelligent function is enabled.

 - Gray indicates that the intelligent function is disabled.

- Play/Pause button: This enables or disables presenter tracking on the camera.
- In-Frame button: This enables or disables debug mode. Debug mode shows the following depending on the camera's mode:
 - Presenter tracking: Debug mode shows a box around faces in the camera shot. Green boxes indicate participants, and red boxes indicate active presenters.
 - Speaker Tracking: Debug mode shows a green Direction of Audio (DoA) bar in the reference camera's video feed. When no audio is detected, the DoA bar rests on the left side of the camera feed. When audio is detected, the DoA bar moves over the speaking participant.

The circle next to the button indicates the status of Debug mode.

- Grey circle: Debug mode is off.
- White circle: Debug mode is on.

In-Frame Button



Reserved Presets

Crestron 1 Beyond cameras have reserved presets that control intelligent camera functionality, intelligent function configuration, provide access to the OSD menu, and restart the camera.

The following camera presets are reserved for their respective functions.

Home Shot and Tracking Shot

The **Home Shot (Preset 0)** and **Tracking Shot (Preset 1)** are reserved presets and are required to be set for proper intelligent camera functionality. For more information on setting **Preset 0** and **Preset 1**, refer to [Tracking Menu on page 191](#).

Start/Stop Tracking

Preset 80 starts the camera's respective intelligent function (Group Framing or Presenter Tracking). **Preset 81** pauses the camera's respective intelligent function. The camera will not perform Group Framing or Presenter Tracking while paused, but will continue to display the camera's video feed. For more information on configuring a camera's intelligent function, refer to [Tracking Menu on page 191](#).

Additionally, an IV-CAM-I20 series camera can start (**Preset 82**) or pause (**Preset 83**) Group Tracking. For more information about Group Tracking, refer to [Presenter Tracking Settings on page 222](#).

Intelligent Switching Presets

If an Intelligent Switching configuration is used, **Preset 84** can be called to resume or pause the Intelligent Switching function. For more information, refer to [Intelligent Switching on page 232](#).

If only one camera's video feed is desired in a Multi-Camera Switching configuration:

- Call **Preset 85** to display the Group Framing camera's video feed and to pause Intelligent Switching. The camera's tracking state is unaffected by calling **Preset 85**.
- Call **Preset 86** to display the Presenter Tracking camera's video feed and to pause Intelligent Switching. The camera's tracking state is unaffected by calling **Preset 86**.

List of Reserved Presets

The following table lists all available reserved presets for Crestron 1 Beyond cameras.

Reserved Presets

Preset	Function	Cameras
0	Home Shot	IV-CAM-I12 IV-CAM-I20, and IV-CAM-I12D-B
1	Tracking Shot	IV-CAM-I12, IV-CAM-I20, and IV-CAM-I12D-B
80	Start Tracking	IV-CAM-I12, IV-CAM-I20, and IV-CAM-I12D-B

Preset	Function	Cameras
81	Pause Tracking	IV-CAM-I12, IV-CAM-I20, and IV-CAM-I12D-B
82	Start Group Tracking	IV-CAM-I20
83	Pause Group Tracking	IV-CAM-I20
84	Resume Intelligent Switching	IV-CAM-I12
85	Pause Intelligent Switching, output Host camera feed	IV-CAM-I12, and IV-CAM-I12D-B
	NOTE: Tracking remains enabled when calling Preset 85 . Preset 81 must be called to pause Tracking.	
86	Pause Intelligent Switching, output Presenter Tracking camera feed	IV-CAM-I12, and IV-CAM-I12D-B
	NOTE: Presenter Tracking remains enabled when calling Preset 86 . Preset 81 must be called to pause Presenter Tracking.	
87	Enable Group Framing	IV-CAM-I12D-B
88	Unavailable	IV-CAM-I12D-B
89	Enable Speaker Tracking	IV-CAM-I12D-B
95	OSD Menu Toggle	All cameras
99	Reboot	All cameras
101	Preset Zone 1	IV-CAM-I20
102	Preset Zone 2	IV-CAM-I20
103	Preset Zone 3	IV-CAM-I20
104	Preset Zone 4	IV-CAM-I20
105	Tracking Profile 1	IV-CAM-I20
106	Tracking Profile 2	IV-CAM-I20
107	Tracking Profile 3	IV-CAM-I20
108	Tracking Profile 4	IV-CAM-I20

On-Screen Display (OSD)

Crestron 1 Beyond cameras have an integrated On-Screen Display (OSD) menu where camera settings can be changed. To access the OSD menu, select **Menu** on the desired camera in the camera list.

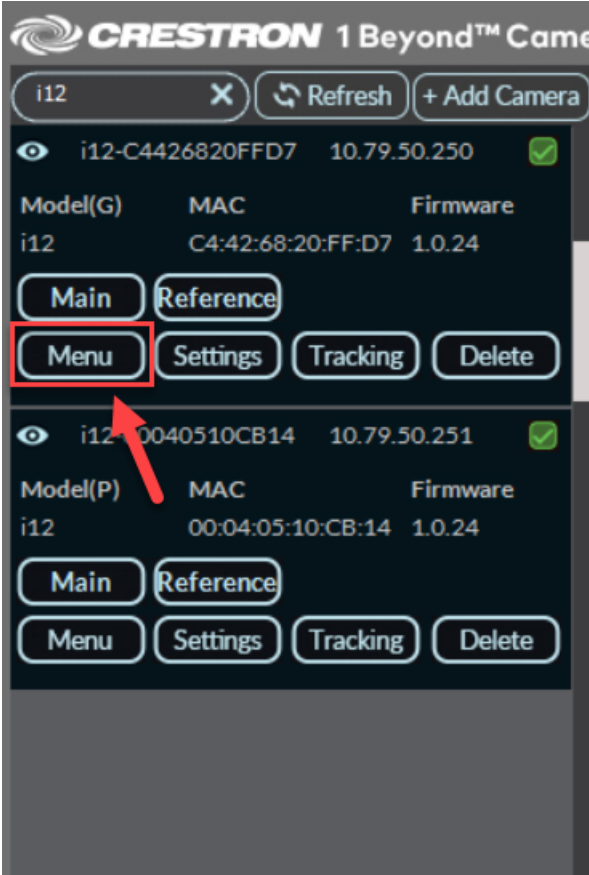

The OSD menu is then displayed overlaid on the camera's video feed.

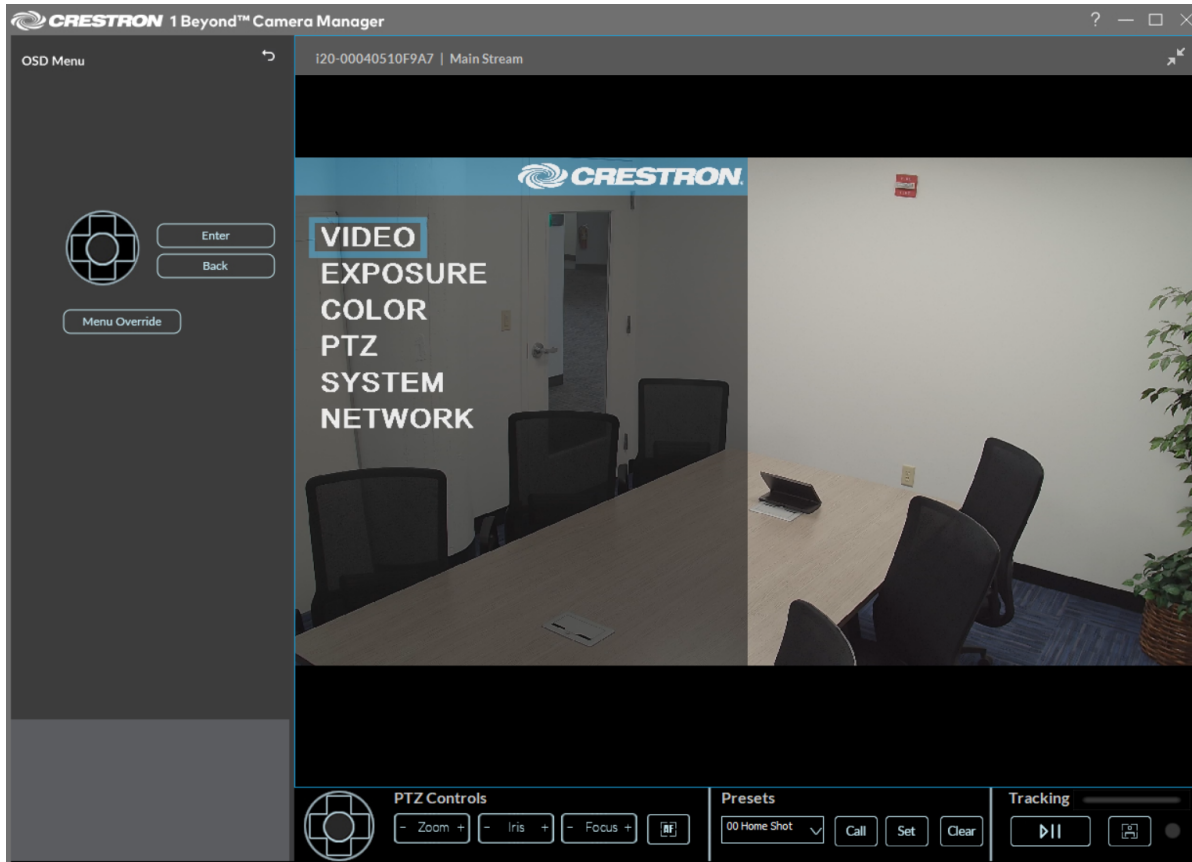

Alternatively, the OSD menu can be accessed with the [IV-CAMA-REMOTE](#) Crestron 1 Beyond IR Camera Remote. To access the OSD menu with the IR camera remote, press **Menu** on the remote.

Menu Navigation

Use the navigation pad to navigate through the OSD menu. Select **Enter** to open a sub menu and select **Back** to exit the sub menu. Use the navigation pad to move up and down through the menus, and left and right to scroll through menu options. Refer to the table below for information on navigating through the OSD sub menus.

OSD Menu Options

Option	Sub Menu Options	Setting Range	Setting Description
Video	Sharpness	0 - 11	Adjust video sharpening.
	Brightness	0 - 14	Adjust video brightness.
	Contrast	0 - 14	Adjust video contrast.
	Gamma	0 - 4	Adjust video gamma correction.
	2DNR	0 - 7	2D Noise Reduction level.
	3DNR	0 - 7	3D Noise Reduction level.
	DRC	0 - 5	Dynamic Range Compression level.
	Mirror	Off/On	Mirrors camera output.
	Invert	Off/On	Inverts the PTZ camera video feed.
		NOTE: Only IV-CAM-P12 and IV-CAM-P20 cameras can be inverted.	
Video Format	1080p30/29.97/25/60/59.94/50, 720p60/59.94/50/	Adjust camera video output format.	
		NOTE: SDI and HDMI video outputs only.	

Option	Sub Menu Options	Setting Range	Setting Description
Exposure	Mode	Auto	Automatically adjust exposure.
		Manual	Manually adjust exposure.
		Shutter PRI	Shutter priority mode.
		Iris PRI	Iris priority mode.
		Bright	Brightness priority mode.
	Anti-Flicker	OFF/50Hz /60Hz	Reduces flicker induced by 25p and 30p frame rates.
	BLC	Off/On	Turn Back Light Compensation On or Off.
	EXP Comp	Off/On	Turn exposure compensation On or Off.
		-7 - 7	Adjust the exposure compensation of the camera.
	Gain	0 - 14	Adjust the gain of the camera.
Shutter	1/60 - 1/10000	Adjust the shutter speed of the camera.	
Iris	F1.6 - F14, Close	Adjust the aperture of the camera.	
REF Brightness	0 - 14	Adjust the reference camera's video brightness.	

Option	Sub Menu Options	Setting Range	Setting Description
Color	Mode	Auto	Fully automatic white balance.
		Manual	Fully manual white balance adjustment.
		One Push	Trigger a one time white balance adjustment.
		Static	Preset white balance adjustments
	Profile	Cloudy	Static Color Mode presets.
		Daylight	
		Fluorescent	
		Tungsten	
		Custom	
	R-Gain	0 - 16	Adjust the red color channel balance.
	G-Gain	0 - 16	Adjust the green color channel balance.
	B-Gain	0 - 16	Adjust the blue color channel balance.
	WB Sens	Low/Medium/High	Adjust white balance sensitivity.
Saturation	0 - 14	Increase or decrease color saturation.	
Hue	0 - 14	Increase or decrease video hue.	

Option	Sub Menu Options	Setting Range	Setting Description
PTZ	Speed	1 - 7	Adjust the speed of camera movement.
	AF Sens	Low/Medium/High	Adjusts the AutoFocus sensitivity
	AF Area	Global/Center/Face NOTE: Face AF Area is only available with p-series cameras.	Set the Auto-Focus area to be used: <ul style="list-style-type: none"> • Global uses the full PTZ image provided. • Center focuses from the center of lens first. • Face prioritizes faces within the scene.
	PTZ Trig AF	Off/On	Auto-focus after moving the camera.
	Preset Freeze	Off/On	Turn Preset Freeze On or Off.
	Auto Privacy	Off/On	Turn automatic Privacy Mode On or Off
	Home Shot	Off/On	Enables Preset 0 (Home Shot) to be called upon camera wake action
	Digital Zoom	Off/On	Turn Digital Zoom On or Off.
	Limit	x1 - x16	Adjust the Digital Zoom limit.
Calibrate	Confirm	When selected, the camera will perform focus calibration. Refer to Focus Calibration on page 175 for more information about focus calibration.	

Option	Sub Menu Options	Setting Range	Setting Description
System	Address	1 - 7	Choose the camera address for serial and IP communication.
	Protocol	VISCA	Choose the protocol for serial and IP communication.
		PELCO-D	
		PELCO-P	
	Baudrate	2400 - 38400	Set the baud rate for the serial port.
	Disable LED	Off/On	Turn the camera LED On or Off.
	Group Track	Off/On	Turn Group Tracking On or Off.
			NOTE: IV-CAM-I20 only.
	Track Mode	Presenter/Group	Set the IV-CAM-I12 to Presenter Track or Group Frame.
	IR	Off/On	Turn the IR receiver On or Off.
		NOTE: IV-CAM-I12 only.	
IR Address	1/2/3	Set the IR address for the camera.	
MJPEG Only	Off/On	Turn MJPEG Only mode On or Off.	
		TIP: When MJPEG Only mode is enabled, the camera only outputs video in a MJPEG format via USB. This provides compatibility with video conferencing platforms or video adapters that do not support Intelligent Switching due to an incompatible format.	

Option	Sub Menu Options	Setting Range	Setting Description
	Room Size	Large	Set the size of the room the camera is used in. Large room size is intended for presenter tracking up to 35 ft from the camera.
		Extra Large	Extra Large room size is intended for presenter tracking 35 to 55 ft from the camera. NOTE: IV-CAM-I20 only.
	Show Preset#	Off/On	Turn the Preset number On or Off on the video feed.
	FW Version	n/a	Displays the camera firmware version.
	Reset OSD	Confirm	Select Confirm to reset OSD menu settings to the factory default.
Network	Mode	Static IP DCHP	Set the camera IP connection method.
	IP	n/a	Displays the camera's IP address.
	Subnet	n/a	Displays the camera's subnet mask address.
	Gateway	n/a	Displays the camera's static gateway address.
	DNS 1	n/a	Displays the camera's static primary DNS lookup address.
	DNS 2	n/a	Displays the camera's static secondary DNS lookup address.

IV-CAM-I12D-B Menu Navigation

The IV-CAM-I12D-B camera contains different values and options compared to the other IV-CAM Series cameras. Refer to the table below for information on navigating through the OSD sub menus.

IV-CAM-I12D-B OSD Menu Options

Option	Sub Menu Options	Setting Range	Setting Description
Video	Lens	PTZ/Reference	Selects either the PTZ cameras or Reference camera for settings.
	Sharpness	0 - 11	Adjust video sharpening.
	Brightness	0 - 14	Adjust video brightness.
	Contrast	0 - 14	Adjust video contrast.
	Gamma	0 - 4	Adjust video gamma correction.
	2DNR	0 - 7	2D Noise Reduction level.
	3DNR	0 - 7	3D Noise Reduction level.
	DRC	0 - 5	Dynamic Range Compression level.
	Mirror	Off/On	Mirrors camera output.
	Video Format	4Kp25/29.97/30 1080p30/29.97/25/60/59.94/50, 720p60/59.94/50/	Adjust camera video output format.
	Distort Correct	Off/On	Turn the Reference Camera Distortion Correction On or Off.

NOTE: HDMI video outputs only.

Option	Sub Menu Options	Setting Range	Setting Description
Exposure	Lens	PTZ/Reference	Selects either the PTZ cameras or Reference camera for settings.
	Mode	Auto	Automatically adjust exposure.
		Manual	Manually adjust exposure.
		Shutter PRI	Shutter priority mode.
		Aperture PRI	Aperture priority mode.
		Bright	Brightness priority mode.
	Anti-Flicker	OFF/50Hz /60Hz	Reduces flicker induced by 25p and 30p frame rates.
	BLC	Off/On	Turn Back Light Compensation On or Off.
	EXP Comp	Off/On	Turn exposure compensation On or Off.
		-7 - 7	Adjust the exposure compensation of the camera.
	Gain	0 - 14	Adjust the gain of the camera.
	Shutter	1/60 - 1/10000	Adjust the shutter speed of the camera.
Iris	F1.6 - F14, Close	Adjust the aperture of the camera.	
REF Brightness	0 - 14	Adjust the reference camera's video brightness.	

Option	Sub Menu Options	Setting Range	Setting Description
Color	Lens	PTZ/Reference	Selects either the PTZ cameras or Reference camera for settings.
	Mode	Auto	Fully automatic white balance.
		Manual	Fully manual white balance adjustment.
		One Push	Trigger a one time white balance adjustment.
		Static	Preset white balance adjustments
		Auto-R	Automatically adjust white balance to match the Reference Camera
	Profile	Cloudy	Static Color Mode presets.
		Daylight	
		Fluorescent	
		Tungsten	
		Custom	
	R-Gain	0 - 16	Adjust the red color channel balance.
	G-Gain	0 - 16	Adjust the green color channel balance.
B-Gain	0 - 16	Adjust the blue color channel balance.	
WB Sens	Low/Medium/High	Adjust white balance sensitivity.	
Saturation	0 - 14	Increase or decrease color saturation.	
Hue	0 - 14	Increase or decrease video hue.	

Option	Sub Menu Options	Setting Range	Setting Description
PTZ	Speed	1 - 7	Adjust the speed of camera movement.
	AF Sens	Low/Medium/High	Adjusts the AutoFocus sensitivity
	AF Area	Global/Center/Face/Foreground	Set the Auto-Focus area to be used: <ul style="list-style-type: none"> • Global uses the full PTZ image provided. • Center focuses from the center of lens first. • Face prioritizes faces within the scene. • Foreground prioritizes objects nearest to the camera
	PTZ Trig AF	Off/On	Auto-focus after moving the camera.
	Preset Freeze	Off/On	Turn Preset Freeze On or Off.
	Auto Privacy	Off/On	Turn automatic Privacy Mode On or Off
	Home Shot	Off/On	Enables Preset 0 (Home Shot) to be called upon camera wake action
	Digital Zoom	Off/On	Turn Digital Zoom On or Off.
Calibrate	Confirm	When selected, the camera will perform focus calibration. Refer to Focus Calibration on page 175 for more information about focus calibration.	

Option	Sub Menu Options	Setting Range	Setting Description
System	Address	1 - 3	Choose the camera address for serial and IP communication.
	Protocol	VISCA	Choose the protocol for serial and IP communication.
		PELCO-D	
		PELCO-P	
	Baudrate	2400 - 38400	Set the baud rate for the serial port.
	Disable LED	Off/On	Turn the camera LED On or Off.
	Layout	Standard/PiP	Switches between a full-screen (Standard) and picture and picture (PiP) camera shot layouts.
	IR	Off/On	Turn the IR receiver On or Off.
	IR Address	1/2/3	Set the IR address for the camera.
MJPEG Only	Off/On	Turn MJPEG Only mode On or Off.	
<div style="background-color: #e1f5fe; padding: 10px; border: 1px solid #00796b; margin: 10px 0;"> <p>TIP: When MJPEG Only mode is enabled, the camera only outputs video in a MJPEG format via USB. This provides compatibility with video conferencing platforms or video adapters that do not support Multi-Camera Switching due to an incompatible format.</p> </div>			
Show Preset#	Off/On	Turn the Preset number On or Off on the video feed.	
FW Version	n/a	Displays the camera firmware version.	
Reset OSD	Confirm	Select Confirm to reset OSD menu settings to the factory default.	

Option	Sub Menu Options	Setting Range	Setting Description
Network	Mode	Static IP	Set the camera IP connection method.
		DCHP	
	IP	n/a	Displays the camera's IP address.
	Subnet	n/a	Displays the camera's subnet mask address.
	Gateway	n/a	Displays the camera's static gateway address.
	DNS 1	n/a	Displays the camera's static primary DNS lookup address.
	DNS 2	n/a	Displays the camera's static secondary DNS lookup address.

Focus Calibration

Focus calibration should be performed when the camera appears to be off focus at various zoom levels. Complete the following procedure to calibrate the focus of the PTZ camera:

1. At the bottom of the user interface, use the **PTZ Controls** to aim and zoom the camera's PTZ lens at the farthest object in the room.
2. Select the **Menu** button to open the OSD menu.
3. Select the **PTZ** option within the OSD menu.
4. Select the **Calibration** option.

The camera performs the focus calibration for the PTZ lens. The focus calibration process may take up to 3 minutes to be complete.

NOTE: Ensure that no objects or people move in front of the camera during this process.

Advanced Camera Settings

This section contains information on the Crestron 1 Beyond camera advanced settings. These are used to change the protocol, network, user, and firmware update settings.

To access the **Advanced Settings** menu, select **Settings** on the desired camera in the camera list.

Settings Select

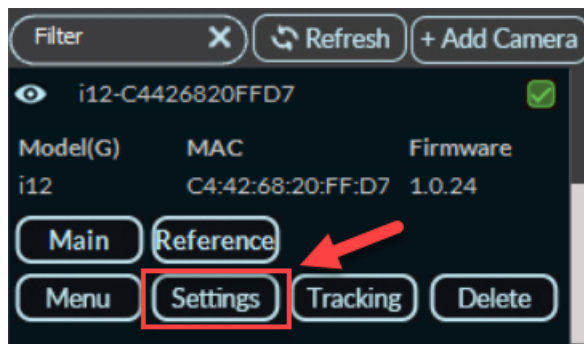

The **Advanced Settings** menu is displayed.

Advanced Settings Menu

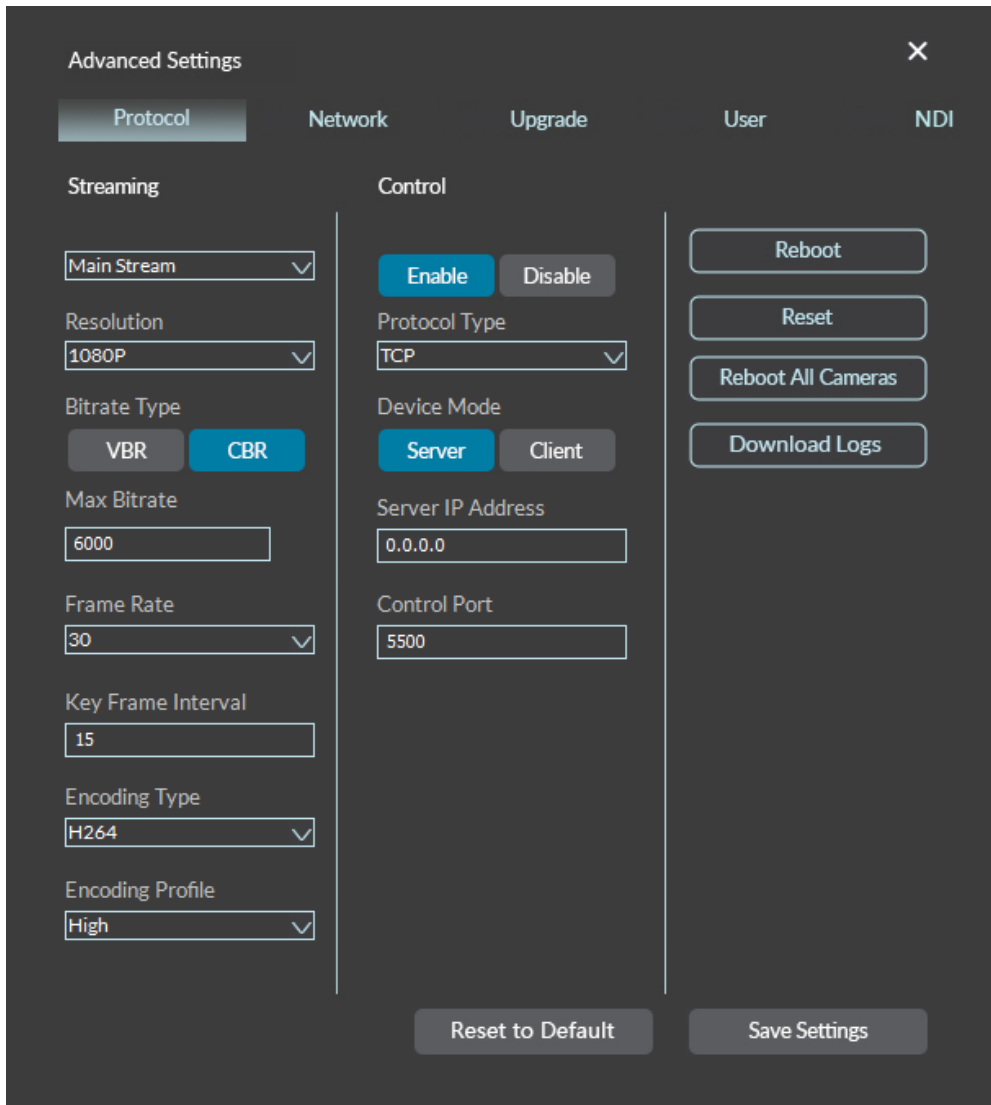

Protocol Settings

The **Protocol** settings are displayed by default when the **Advanced Settings** menu is opened. **Protocol** settings include streaming options for camera output and control settings for interacting with control devices.

Select the **Save Settings** button in the bottom right of the **Advanced Settings** window to save any changes made.

Protocol Tab

Advanced Settings ×

Protocol Network Upgrade User NDI

Streaming

Main Stream

Resolution

Bitrate Type

VBR CBR

Max Bitrate

Frame Rate

Key Frame Interval

Encoding Type

Encoding Profile

Control

Enable Disable

Protocol Type

Device Mode

Server Client

Server IP Address

Control Port

The following **Protocol** settings are available.

Streaming

Streaming settings are used to adjust the properties of the native IP video streams that are encoded and transmitted by the camera.

Streaming Settings

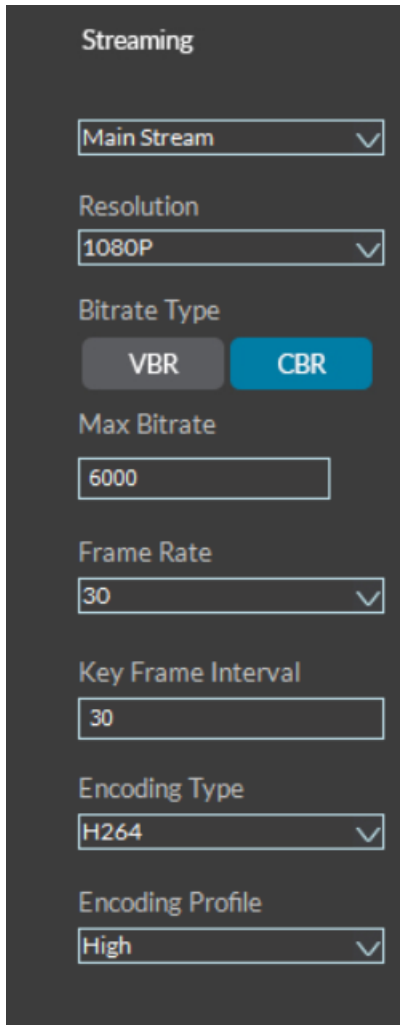

The screenshot shows a dark-themed settings panel titled "Streaming". It contains the following controls from top to bottom: a dropdown menu for "Main Stream" with "Main Stream" selected; a dropdown menu for "Resolution" with "1080P" selected; two buttons for "Bitrate Type", "VBR" and "CBR", with "CBR" highlighted in blue; a text input field for "Max Bitrate" containing "6000"; a dropdown menu for "Frame Rate" with "30" selected; a text input field for "Key Frame Interval" containing "30"; a dropdown menu for "Encoding Type" with "H264" selected; and a dropdown menu for "Encoding Profile" with "High" selected.

The following **Streaming** settings are available.

- **Stream Type:** Select the camera stream to be configured.
- **Resolution:** Select the desired stream resolution independently of the camera's operating resolution.
- **Bitrate Type:** Select whether the video will be encoded with **CBR** (constant) or **VBR** (variable) bit rate. Selecting **VBR** causes reduced stream bit rate during static shots with little movement. The bit rate increases as motion increases.
- **Max Bitrate:** Set the maximum bit rate of the video stream. The default value of **6000** Mbps should be retained for most setups.
- **Frame Rate:** Select the stream's frame rate.

- **Key Frame Interval:** Enter the number of frames that must occur before a keyframe is sent in a video stream.
- **Encoding Type:** Select whether the video stream will use **H.264** or **H.265** encoding.
- **Encode Profile:** Select whether the video stream will use a **low**, **base**, or **high-profile** encoding type.

Control Settings

The **Control** settings are used to set a secondary connection to the camera from a control device.

Control Settings

The screenshot shows a dark-themed control panel with the following settings:

- Control:** A section header.
- Enable/Disable:** Two buttons. 'Enable' is highlighted in blue, and 'Disable' is greyed out.
- Protocol Type:** A dropdown menu with 'TCP' selected and a checkmark icon.
- Device Mode:** Two buttons. 'Server' is highlighted in blue, and 'Client' is greyed out.
- Server IP Address:** A text input field containing '0.0.0.0'.
- Control Port:** A text input field containing '5500'.

The following **Control** settings are available.

- **Enable and Disable:** Select **Enable** or **Disable** to turn the secondary connections on or off.
- **Protocol Type:** Select the communication protocol for the secondary connection.
- **Device Mode:** Select either **Server** or **Client** to determine the role for the camera when using a secondary connection.
- **Server IP Address:** Enter the IP address for the secondary connection device. The default value of **0.0.0.0** should be retained for most setups.
- **Control Port:** Enter the port number into the **Control Port** text field for the secondary connection. The default value of **5500** should be retained for most setups.

Control Settings (IV-CAM-I12D-B Only)

The following **Control** settings are available only with the IV-CAM-I12D-B.

Control Settings (IV-CAM-I12D-B Only)

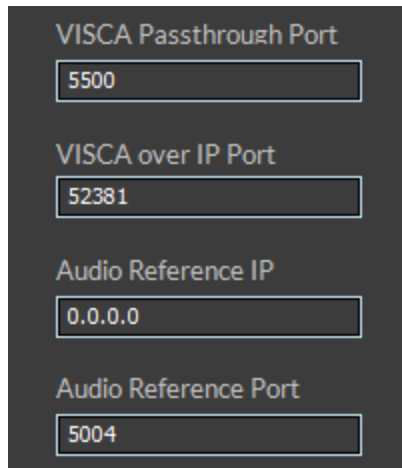

VISCA Passthrough Port	5500
VISCA over IP Port	52381
Audio Reference IP	0.0.0.0
Audio Reference Port	5004

- **VISCA Passthrough Port:** Enter the port number into the **VISCA Passthrough Port** text field for the VISCA connection. The default value of **5500** should be retained for most setups.
- **VISCA over IP Port:** Enter the port number into the **VISCA over Port** text field for the network VISCA connection. The default value of **52381** should be retained for most setups. This protocol use standard VISCA commands preceded by an 8-byte header.
- **Audio Reference IP:** Enter the IP address of the audio device's AES67 stream to have the camera ignore the incoming audio during Speaker Tracking. Alternatively, this configuration can be achieved via the **AUDIO REF** port of the camera without requiring an Audio Reference IP. For more information about the **AUDIO REF** port, refer to [Connect the IV-CAM-I12D-B Camera on page 108](#).
- **Audio Reference Port:** Enter the port number into the **Audio Reference Port** text field for the AES67 connection.

Other Settings

The following miscellaneous settings are available.

Other Settings

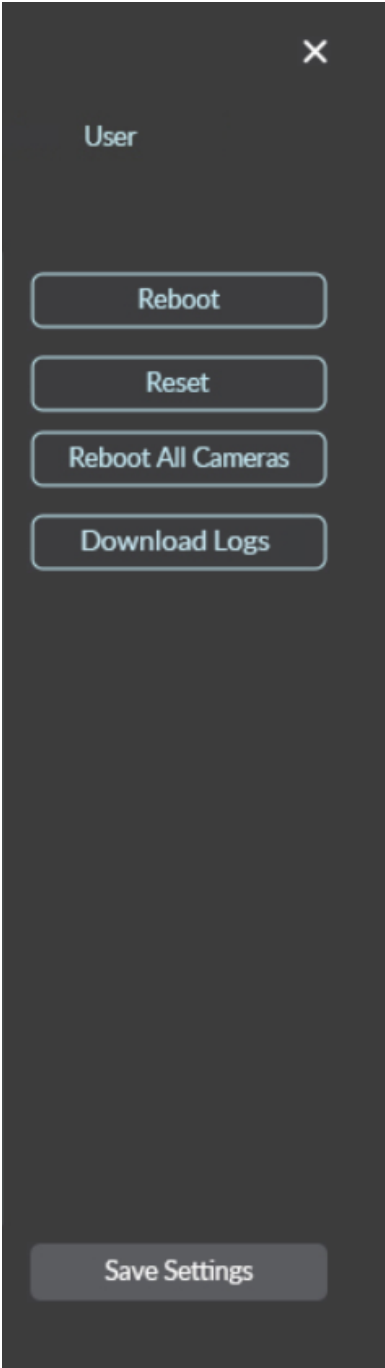

- **Reboot** : Select to restart the camera.
- **Reset** : Select to restore all settings on the camera back to the factory default.

CAUTION: Performing a factory restore returns all settings to their default values and removes any static IP addresses for the camera. For more information on setting a static IP address, refer to [Set a Static IP Address on page 135](#).

- **Reboot All Cameras:** Select to restart all cameras available in the camera list.
- **Download Logs:** Select to download log files for the camera onto the computer operating Camera Manager.

Network Settings

The **Network** settings contain the camera's network settings for the camera's video streams, time settings, and autoupdate settings. Select the **Save Settings** button in the bottom right of the **Advanced Settings** window to save any changes made.

To access the **Network** settings, select the **Network** tab on the top of the **Advanced Settings** menu.

Network Menu

The screenshot shows the 'Advanced Settings' window with the 'Network' tab selected. The window has a dark background and a close button (X) in the top right corner. At the top, there are five tabs: 'Protocol', 'Network' (selected), 'Upgrade', 'User', and 'NDI'. The 'Network' tab contains the following settings:

Setting	Value
IP Type	DHCP
IP Address	172.22.149.37
Mask	255.255.0.0
Gateway	172.22.0.2
DNS 1	172.22.0.2
DNS 2	
NTP	Enable (selected), Disable, 19:09
NTP Server	pool.ntp.org
Time Zone Offset	+00:00
Auto-Update	Enable, Disable (selected)
Manifest URL	https://crestrondevicefiles.blob.core.windows.net/iv-cam/prod
Auto-Update Time	02:00

A 'Save Settings' button is located at the bottom right of the window.

The following **Network** settings are available.

- **IP Type:** Select whether the camera connects to the network over a static IP address or dynamically over a **DHCP** IP address. If set to **Static IP**, configure the following options:
 - **IP Address:** Enter a static IP address for the camera.
 - **Mask:** Enter a static subnet mask address for the camera.
 - **Gateway:** Enter a static address for the default gateway router.
 - **DNS 1:** Enter a static primary DNS (Domain Name Server) lookup address.
 - **DNS 2:** Enter a static secondary DNS (Domain Name Server) lookup address.
- **RTSP Port:** Enter a port that will be used for the camera's RTSP video-over-IP streams. For more information about accessing the RTSP streams, refer to [Accessing the RTSP Streams on page 186](#).

NOTE: Only RTSP values of 554 and the range of 3479–7999 are supported.

- **App Port:** Enter a port that will be used for communication between the Crestron 1 Beyond Camera Manager 2 software and the camera.

NOTE: The **App Port** value should not be changed unless instructed to do so by [Crestron True Blue Support](#).

- **NTP:** Select **Enable** to use Network Time Protocol and sync the camera's clock with the network's time. Select **Disable** to not use NTP.
- **NTP Server:** If **NTP** is enabled, enter the network server into the **NTP Server** text field that NTP will use to obtain the date and time.
- **Time Zone Offset:** Use the **Time Zone Offset** drop-down menu to select the camera's time zone.
- **Auto-Update:** Select **Enable** to allow the camera to perform automatic updates. Select **Disable** to not allow the camera to perform automatic updates. If **Auto-Update** is enabled, configure the following options:

NOTE: It is not recommended to use the Camera Manager's **Auto-Update** tool if the camera is used with a Crestron Flex or Automate VX solution. These systems perform automatic updates for the camera via their own methods.

- **Manifest URL:** Enter the URL that the camera will pull the automatic updates from.

NOTE: Do not change the **Manifest URL** value unless instructed by [Crestron's True Blue Support](#).

- **Auto-Update Time:** Select the desired time for the cameras to perform automatic updates.

Accessing the RTSP Streams

The following credentials are required to access the camera's RTSP stream:

- **Username:** admin
- **Password:** The password set for the camera in camera manager. For more information about changing a camera's password, refer to [User Settings on page 188](#).

RTSP Stream URL

A URL is required to access the RTSP stream of the camera. The URL for the camera's RTSP stream adheres to the following structure: **rtsp://cameraIPAddress:rtspportnumber/x.encodingtype**. Observe the following about the RTSP stream URL:

NOTE: Special characters in a RTSP URL must be escaped by encoding characters into URL escape codes.

- **cameraIPAddress** is the camera's IP address designated within camera manager. For information about the camera's IP address, refer to [Network Settings on page 184](#).
- **rtspportnumber** is the RSTP port designated for the camera. For more information about the RTSP port, refer to [Network Settings on page 184](#).
- **x.encodingtype** is the encoding type used for the camera, as well as the camera feed being accessed. For more information about the encoding type, refer to [Streaming on page 179](#).

Refer to the following information to select which camera feed is used for the RTSP stream:

- **x = 1:** Access the camera's main PTZ feed.
- **x = 2:** Access the camera's reference camera feed.

For IV-CAM-I12D-B cameras:

- **x = 1:** Access the camera's PTZ 1 feed.
- **x = 2:** Access the camera's main PTZ 2 feed.
- **x = 3:** Access the camera's reference camera feed.

For more information on camera streams, refer to [Accessing Camera Feeds on page 149](#).

NOTE: If the credentials for the camera's RTSP stream are required in the stream URL, then the URL can be written as **rtsp://admin:[camerapassword]@[cameraIPAddress]:rtspportnumber/x.encodingtype**

Refer to the following example of a valid RTSP stream URL: **rtsp://10.10.120.145:554/1.h264**.

- The camera's IP address is **10.10.120.145**.
- The camera's RTSP port is **554**.
- The camera feed accessed is the main PTZ camera's feed (x = 1).
- The encoding type used is **h.264**.

Upgrade Settings

The **Upgrade** settings are used to perform manual firmware updates, display the current camera version, and display the upgrade status during a firmware update.

To access the **Upgrade** menu, select **Upgrade** on the top right of the **Advanced Settings** menu.

Upgrade Menu

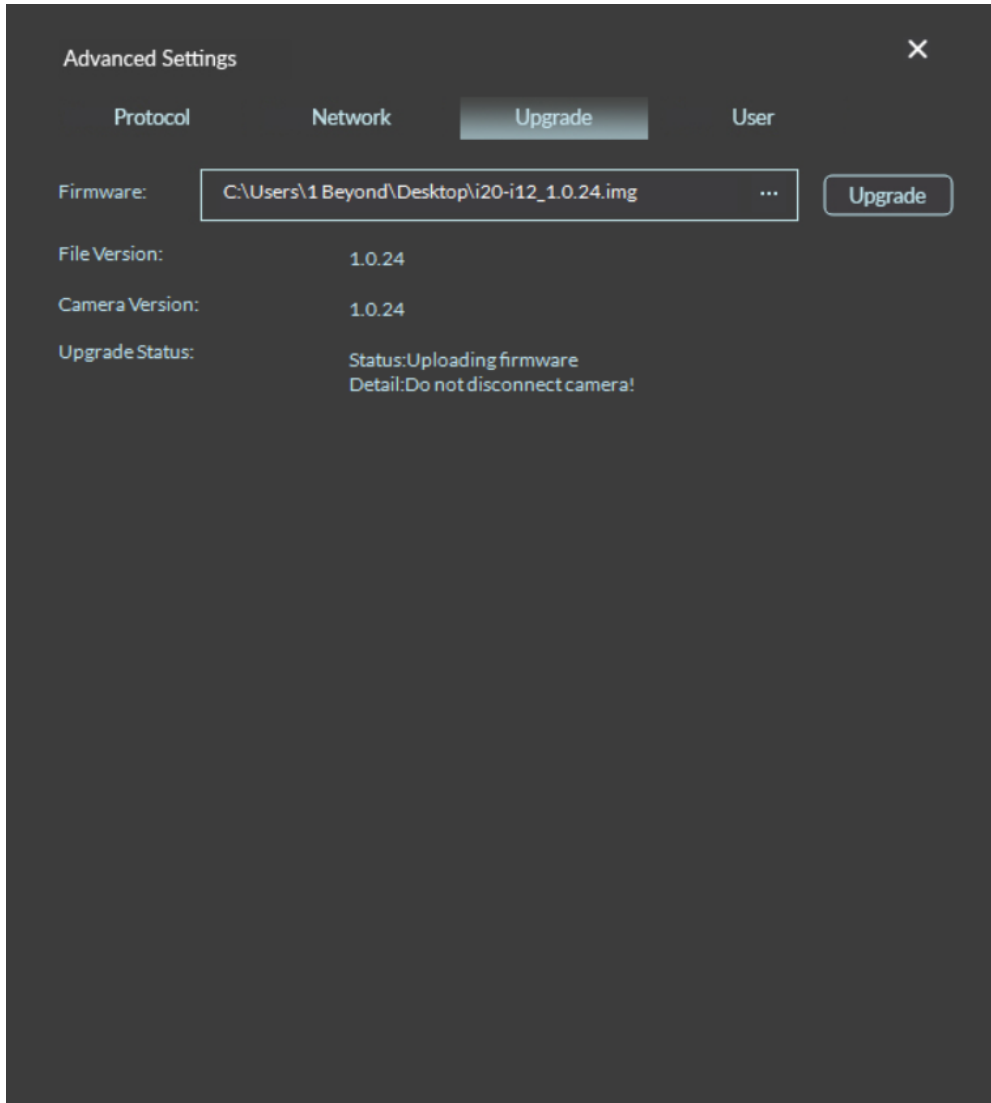

For information on performing a firmware update for the camera, refer to [Update Firmware on page 138](#).

User Settings

The **User** settings show the name of the camera and provides password management. To access the **User** settings, select the **User** tab on the top right of the **Advanced Settings** menu.

User Tab

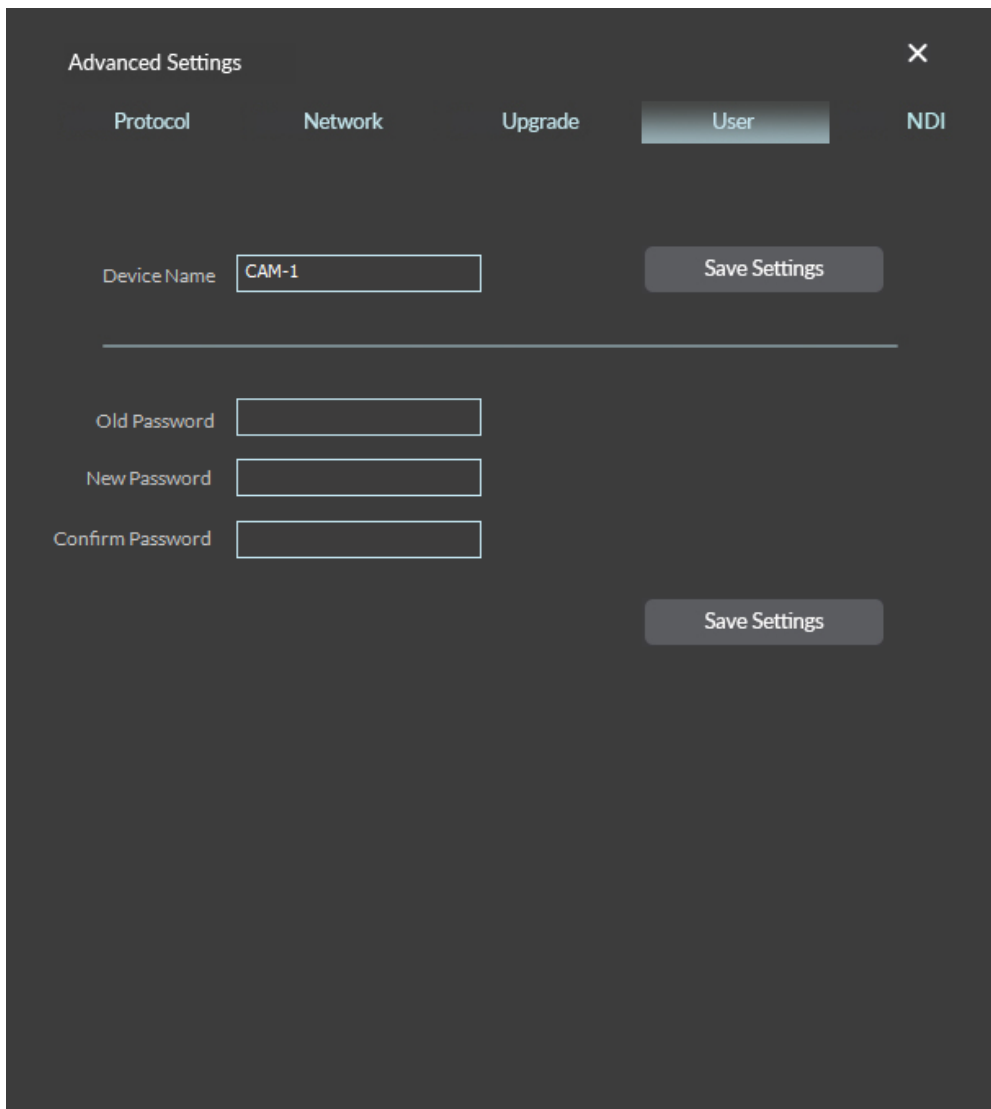

The screenshot shows the 'Advanced Settings' window with the 'User' tab selected. The interface includes a navigation bar with tabs for Protocol, Network, Upgrade, User, and NDI. Below the navigation bar, there are two sections for configuration. The first section has a 'Device Name' field containing 'CAM-1' and a 'Save Settings' button. The second section has three password fields: 'Old Password', 'New Password', and 'Confirm Password', followed by another 'Save Settings' button.

The following **User** settings are available.

- **Device Name:** Set the name of the current camera. The name displayed in the Device Name text field is also the NDI stream name of the camera.

NOTE: If the **Device Name** is changed, the camera requires a restart before the new **Device Name** appears in NDI streams. For more information on how to restart a camera, refer to [Other Settings on page 182](#).

- Change Password: To change the camera's password, perform the following steps.
 1. Enter the current password of the camera in the **Old Password** text field.
 2. Enter the desired new password in the **New Password** text field.
 3. Enter the same new password in the **Confirm Password** text field.
 4. Select **Save Settings** to change the password of the camera.

The camera's password has been updated.

NDI Settings

The NDI settings allow you to enable or disable the camera's NDI output, edit the group and stream names, and configure connections to Discovery and Multicast Servers.

NOTE: NDI settings should not be changed for Automate VX configurations unless instructed to do so by Crestron True Blue Support.

NDI Settings

The screenshot shows a dark-themed 'Advanced Settings' dialog box with a close button (X) in the top right corner. The 'NDI' tab is selected, highlighted in a light blue bar. Below the tab are five sections of settings:

- NDI:** Two buttons, 'Enable' (highlighted in blue) and 'Disable' (grey).
- Receive Group:** Two text input fields: 'Group Name' containing 'Public' and 'Stream Name' containing 'NDI Stream'.
- Discovery Server:** Two buttons, 'Enable' (grey) and 'Disable' (highlighted in blue), and an 'IP Address' text input field containing '0.0.0.0'.
- Multicast Server:** Two buttons, 'Enable' (grey) and 'Disable' (highlighted in blue), and three text input fields: 'IP Address' containing '239.255.0.0', 'Mask' containing '255.255.0.0', and 'TTL' containing '1'.

At the bottom of the dialog are two buttons: 'Reset to Default' and 'Save Settings'.

Select **Enable** to turn on the NDI output or select **Disable** to turn it off. To configure the other NDI settings, refer to [NDI's documentation](#).

Tracking Menu

NOTE: The Tracking menu is only available for IV-CAM-I20 and IV-CAM-I12 cameras.

IV-CAM-I12 and IV-CAM-I20 cameras have intelligent features that require configuration before operation. These include Presenter Tracking, Group Framing, Group Tracking, and **Tracking Settings**.

To access the **Tracking** menu, select the **Tracking** button in the camera list.

Tracking Button

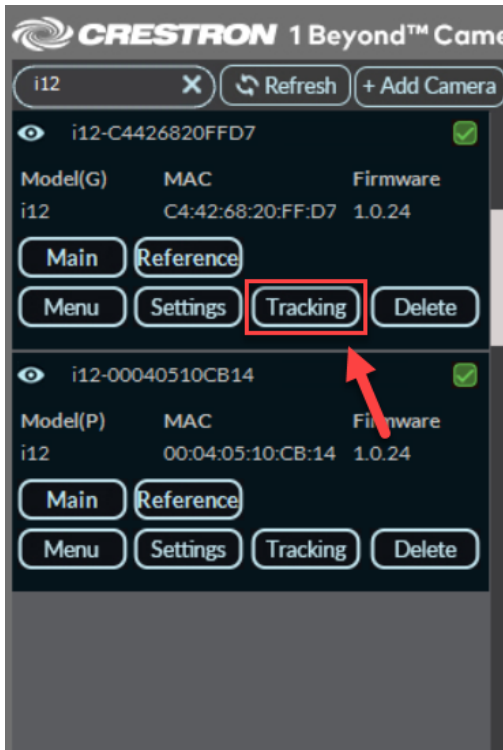

The Tracking Menu is displayed.

NOTE: The IV-CAM-I20 Tracking Menu is shown below as an example.

Tracking Menu

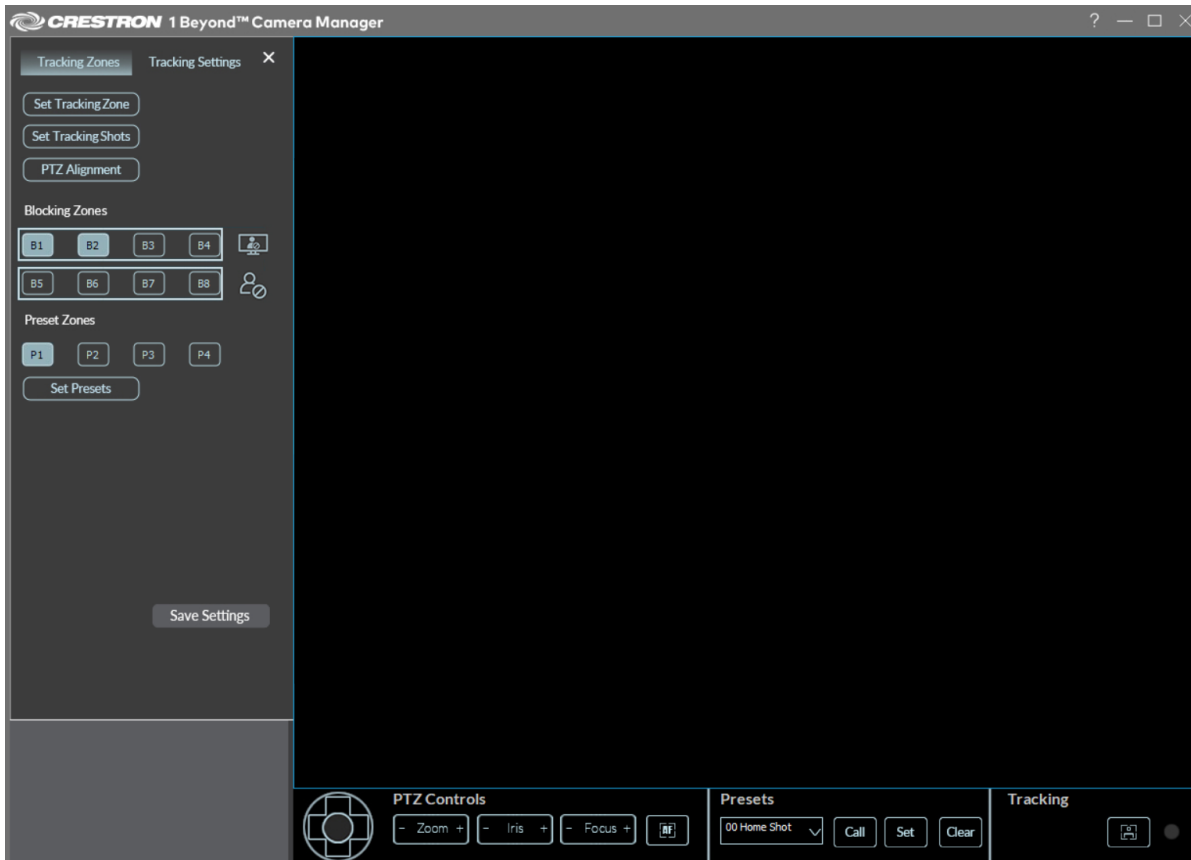

Refer to the following sections to configure the intelligent features of the IV-CAM-I20 or IV-CAM-I12 cameras.

NOTE: Ensure that the room size is set for the camera in the On-Screen Display menu (OSD) before proceeding. Failure to do so can impact the camera's intelligent function. For more information about the On-Screen Display menu (OSD), refer to [On-Screen Display \(OSD\) on page 162](#).

This section provides the following information:

- [Set the Tracking Zone](#)
- [Set the Tracking Shots](#)
- [PTZ Alignment](#)
- [Blocking Zones](#)
- [Preset Zones](#)

Set the Tracking Zone

NOTE: Tracking Zones are only available for the IV-CAM-I20 and IV-CAM-I12 when set to **Presenter** mode. For more information on switching a camera's mode, refer to [Change the Camera Mode on page 142](#)

The camera uses Visual AI to detect faces in the Tracking Zone of its wide-angle lens, then tracks the presenter within the Tracking Zone. The Tracking Zone is indicated in the video frame as a green box.

NOTE: The camera does not save settings automatically. Make sure to save frequently during the setup process.

To draw a **Tracking Zone**:

1. Select **Set Tracking Zone** in the top left of the **Tracking Zones** menu. When selected, the cursor moves into the video frame.

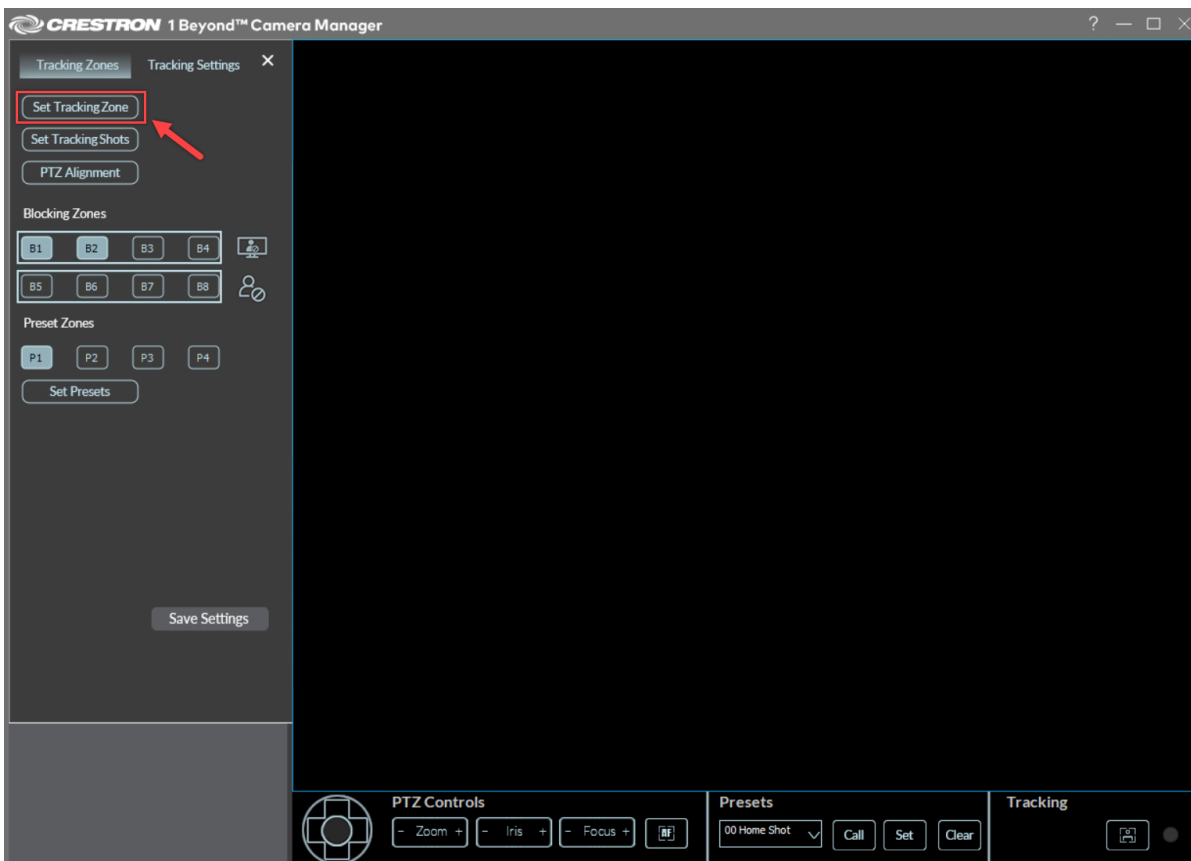

2. Press and hold the cursor over the location in the video frame where the **Tracking Zone** should begin. Then, drag the cursor to create the **Tracking Zone**.

Note the following guidelines when configuring **Tracking Zones**.

- Set the **Tracking Zone** to contain the entire area where a presenter will move around. Draw the **Tracking Zone** so it fills a presenter's head and torso. Tracking is more effective when zones are narrow and defined.
 - Leave room on the left and right of the zones to allow the presenter to leave the zone and another presenter to enter.
 - If the front row of audience seats covers some of the presentation area, do not include it in the **Tracking Zone**. Instead, draw it so that at least the torso and/or head of the presenter will be the only moving subjects in the Tracking Zone.
3. Release the cursor to finish the Tracking Zone. Refer to the image below for an example, the **Tracking Zone** is indicated as a green box.

NOTE: The red box in the image below is the **Blocking Zone** for this configuration. For more information about drawing a **Blocking Zone**, refer to [Blocking Zones on page 205](#).

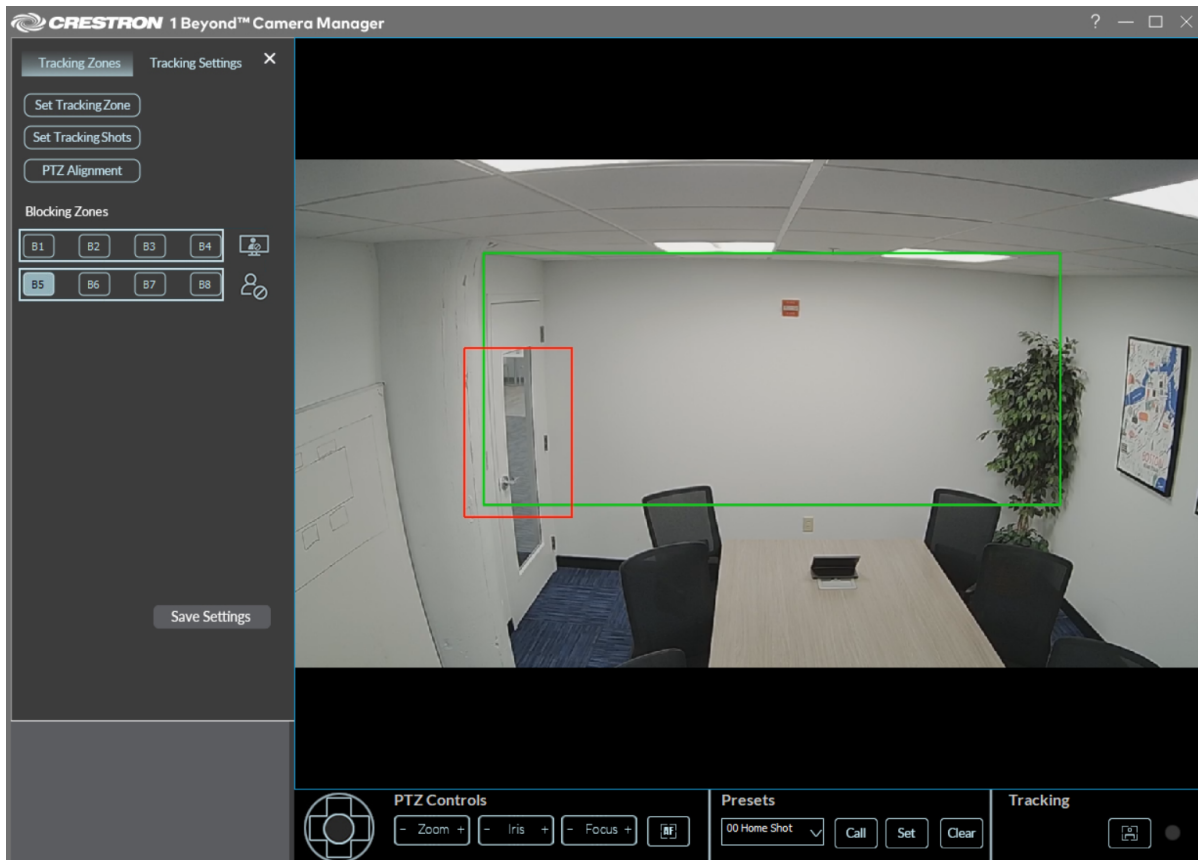

4. Once the **Tracking Zone** is set, select **Save Settings**.

The **Tracking Zone** is now configured to track the presenter.

NOTE: When no presenter is detected or tracked, the camera will revert to the **Home Shot (Preset 0)**. For more information on the **Home Shot (Preset 0)**, refer to [Camera Controls on page 156](#).

Set the Tracking Shots

The **Set Tracking Shots** menu contains **Tracking Shot (Preset 1)** and **Home Shot (Preset 0)** settings. To access the **Set Tracking Shots** menu, select **Set Tracking Shots** in the top left of the **Tracking Zones** menu.

Set Tracking Shots

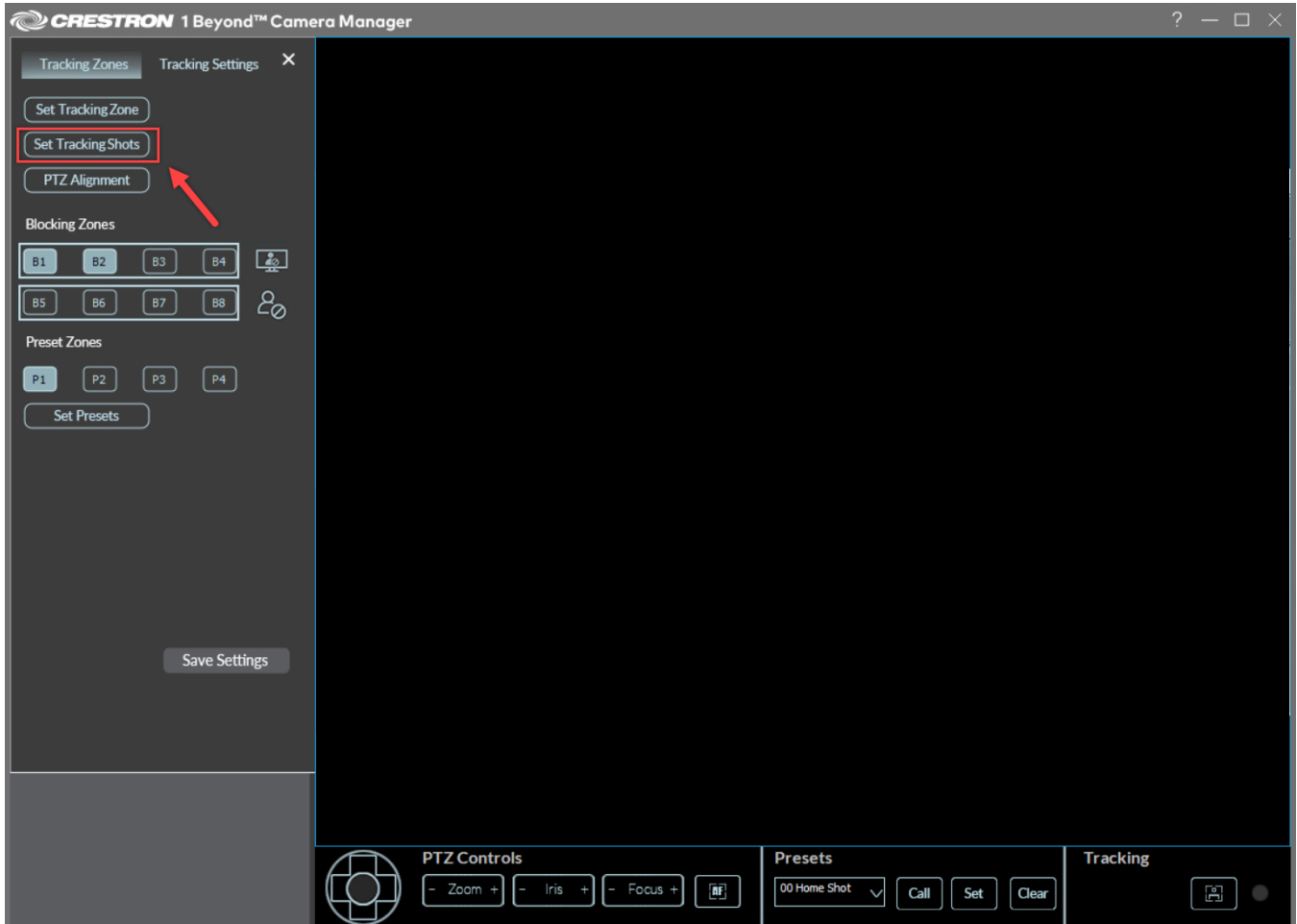

Set Tracking Shots Menu

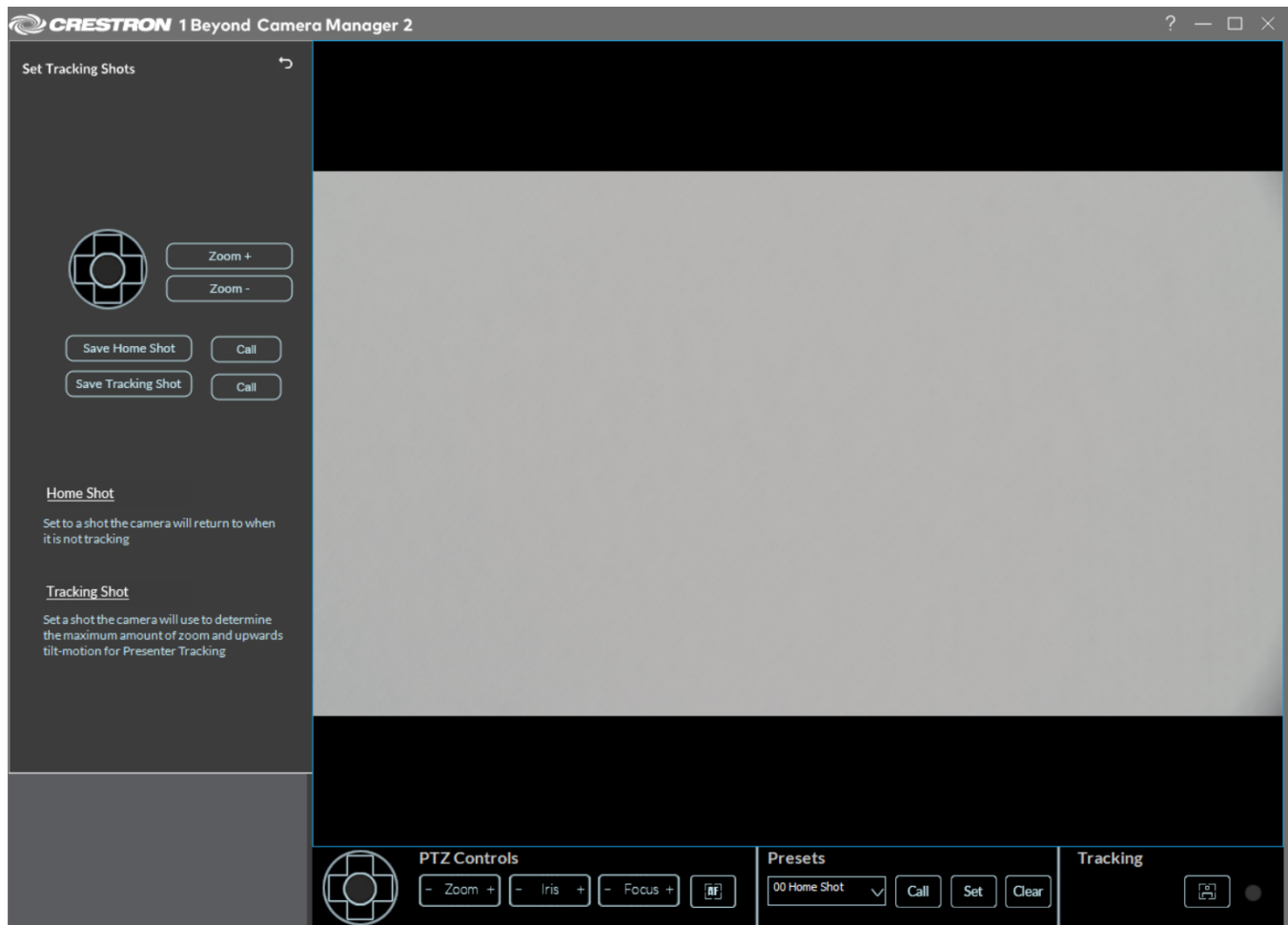

Refer to the sections below to set the Tracking Shot and Home Shot for the camera.

Set the Tracking Shot (Preset 1)

NOTE: Setting the **Tracking Shot** is only available for the IV-CAM-I20, IV-CAM-I12D-B, and IV-CAM-I12 set to **Presenter** mode. For more information on switching a camera's mode, refer to [Change the Camera Mode on page 142](#)

The **Tracking Shot (Preset 1)** determines how tightly the camera frames a presenter while tracking and the maximum amount of zoom and upwards tilt-motion of the tracking shot.

Set Tracking Shots Menu

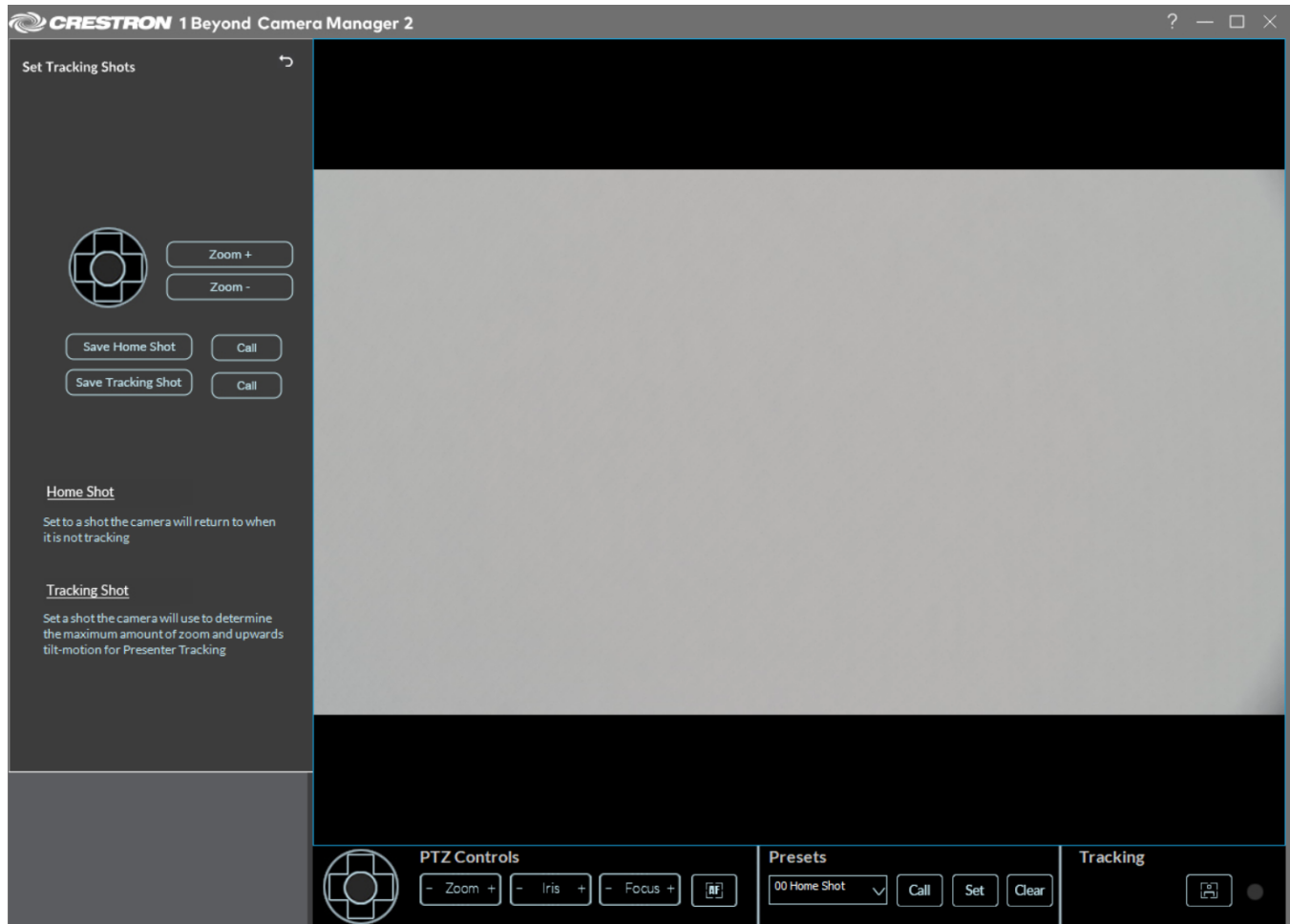

To set the **Tracking Shot (Preset 1)**:

1. Use the navigation pad and the zoom buttons to adjust the camera shot. Have someone act as a subject to determine the optimal camera position and zoom in. Position the camera to ensure the subject fits in the frame in the following situations:
 - The subject stands with outstretched arms.
 - The subject raises a hand to simulate writing on a blackboard or gesturing.
 - Depending on the height of the subject, add enough headroom to allow for taller presenters. The headroom defined in the **Tracking Shot** limits how far up the camera will tilt while tracking.
2. Once the **Tracking Shot** is configured, select **Save Tracking Shot**.

The **Tracking Shot (Preset 1)** is now set.

NOTE: If **Tracking Shot (Preset 1)** is not set, it can lead to the camera shot not being framed correctly, and can lead to poor presenter tracking. Confirm that there is a **Tracking Shot (Preset 1)** set by pressing the **Call** button on the right of the **Save Tracking Shot** button.

Presets Menu

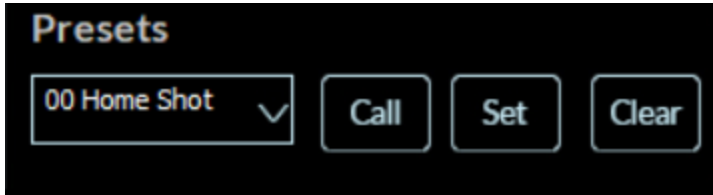

Set the Home Shot

The **Home Shot (Preset 0)** is the shot that the camera reverts to when no presenter is detected or tracked. This preset should be set to view the entire presentation area.

To set the **Home Shot (Preset 0)**:

1. Select **Set Tracking Shots** in the top left of the **Tracking Zones** menu. When selected, the **Set Tracking Shots** menu is displayed.

Set Tracking Shots

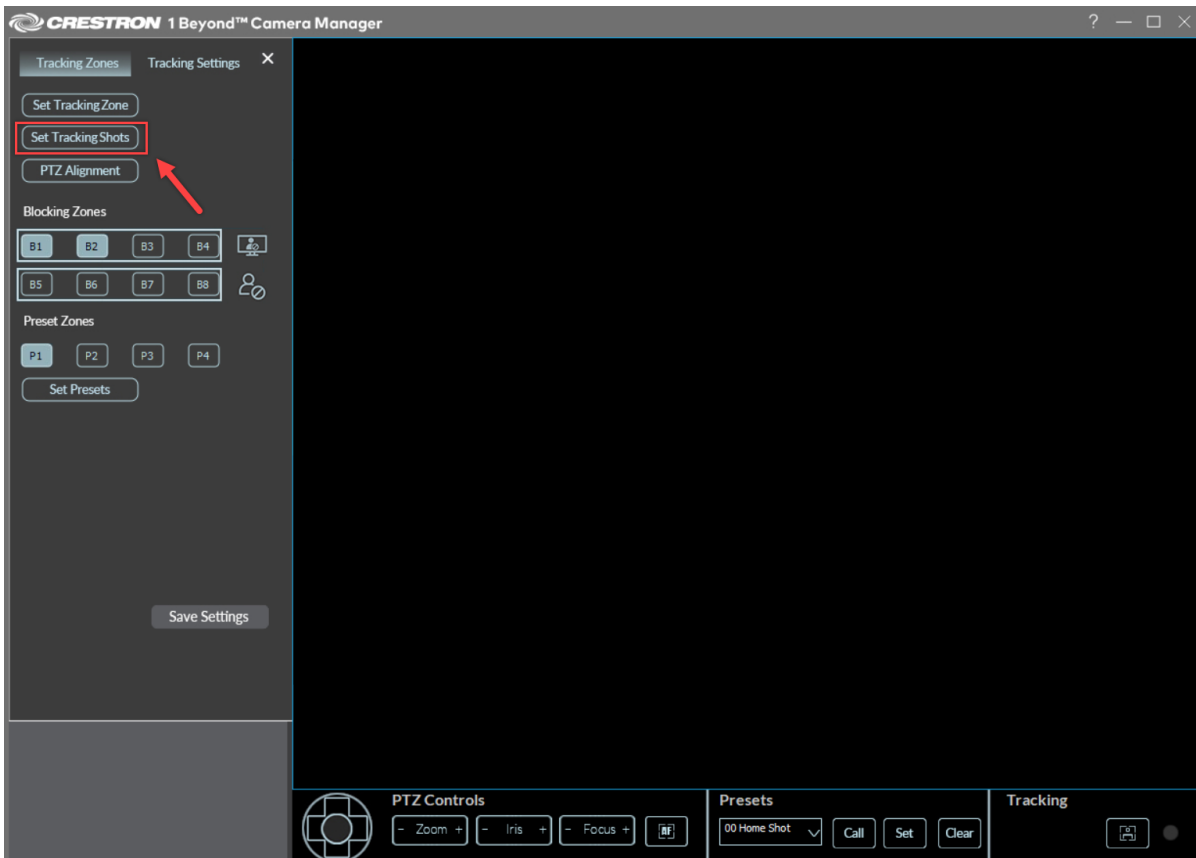

Set Tracking Shots Menu

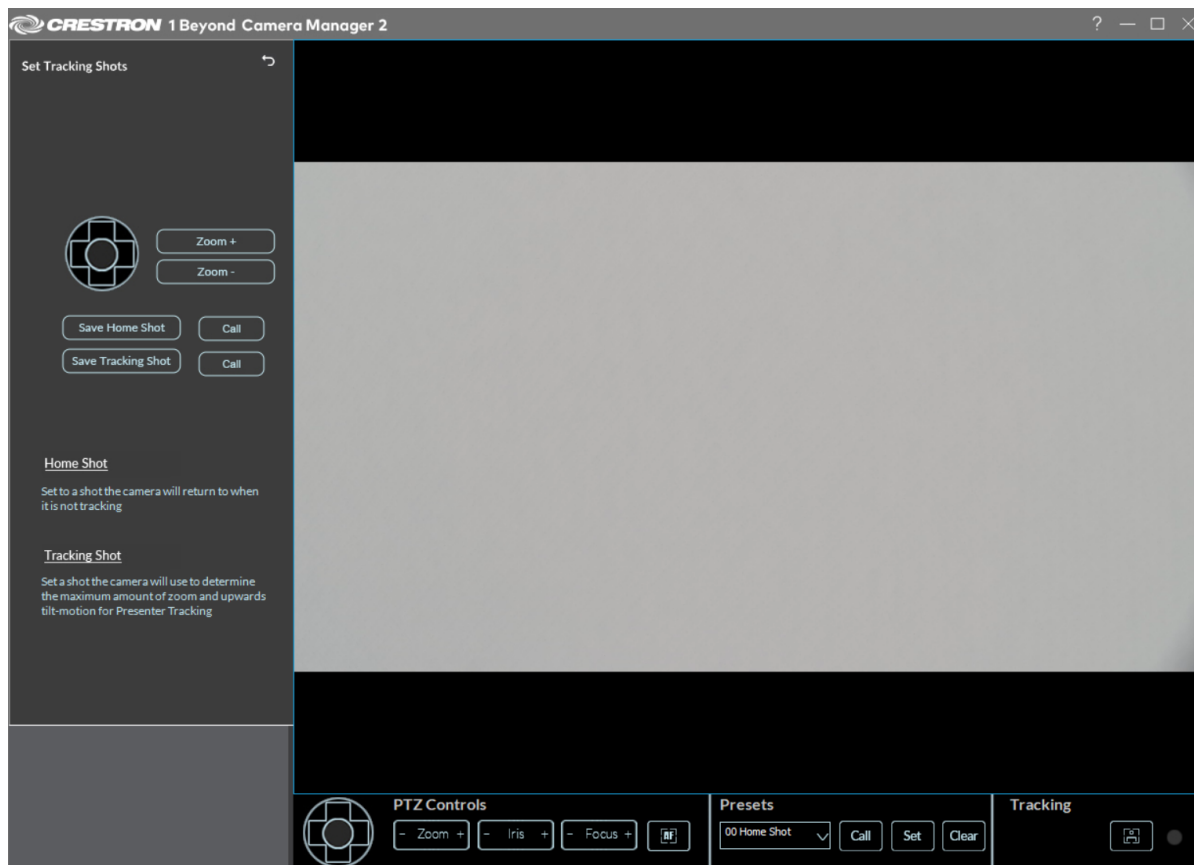

2. Use the navigation pad and the zoom buttons to adjust the camera shot. The camera shot should have a full view of the presentation area.
3. Once the **Home Shot** is configured, select **Save Home Shot**.

NOTE: Press the **Call** button to the right of the **Save Home Shot** button to change the camera shot to view the **Home Shot**.

The **Home Shot (Preset 0)** is now set.

PTZ Alignment

To ensure the best tracking performance, perform a PTZ camera alignment in relation to the static wide-angle reference camera. When the PTZ camera is misaligned with the wide-angle reference camera, it can cause camera shots to not be centered.

To correct PTZ camera alignment in relation to the static wide-angle camera:

1. Open the **Tracking Zones** tab.
2. Select **PTZ Alignment** in the top left of the **Tracking Zones** menu.

Select PTZ Alignment

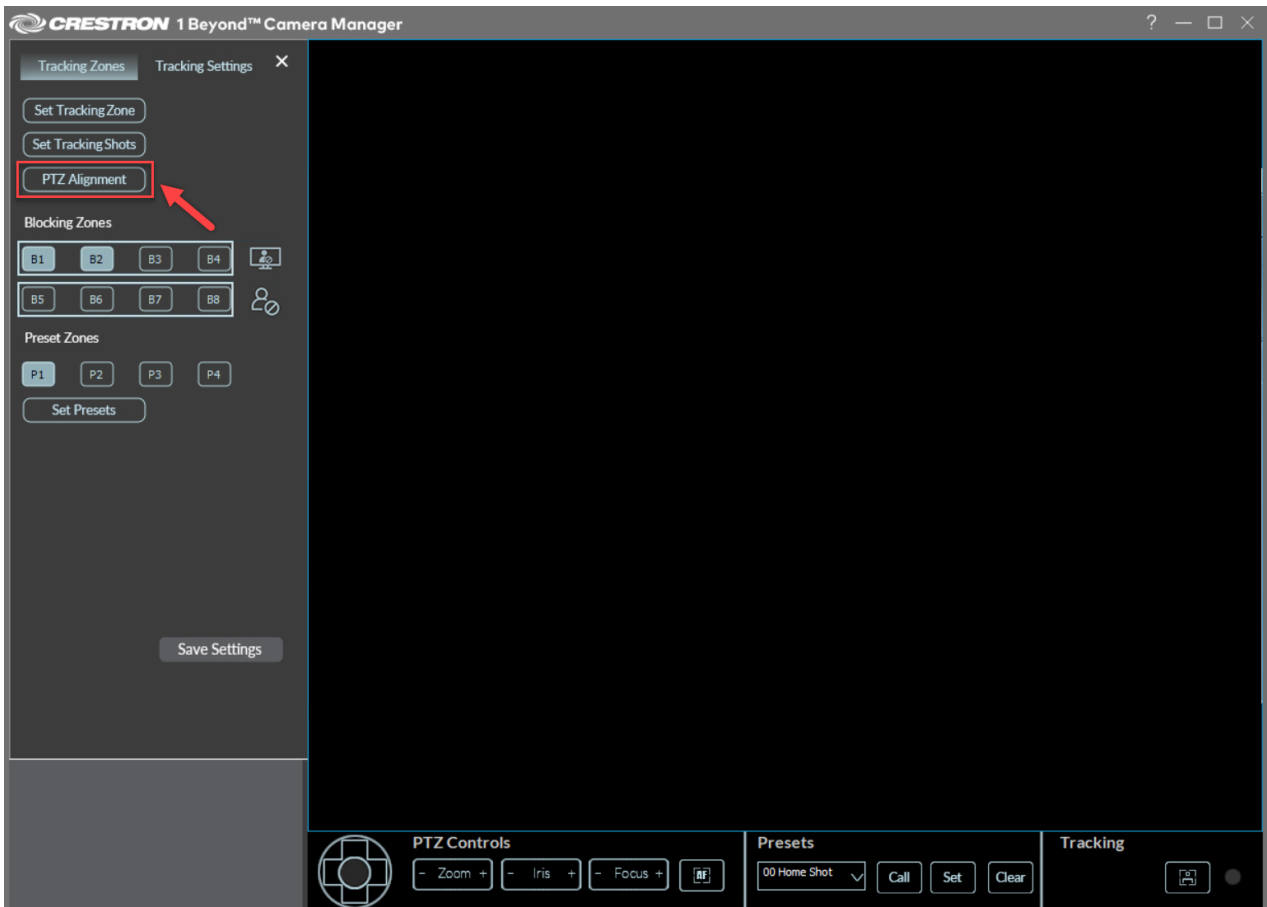

A window is displayed showing the PTZ's video feed and wide-angle camera's video feed overlaid with a blue crosshair.

PTZ Alignment Menu

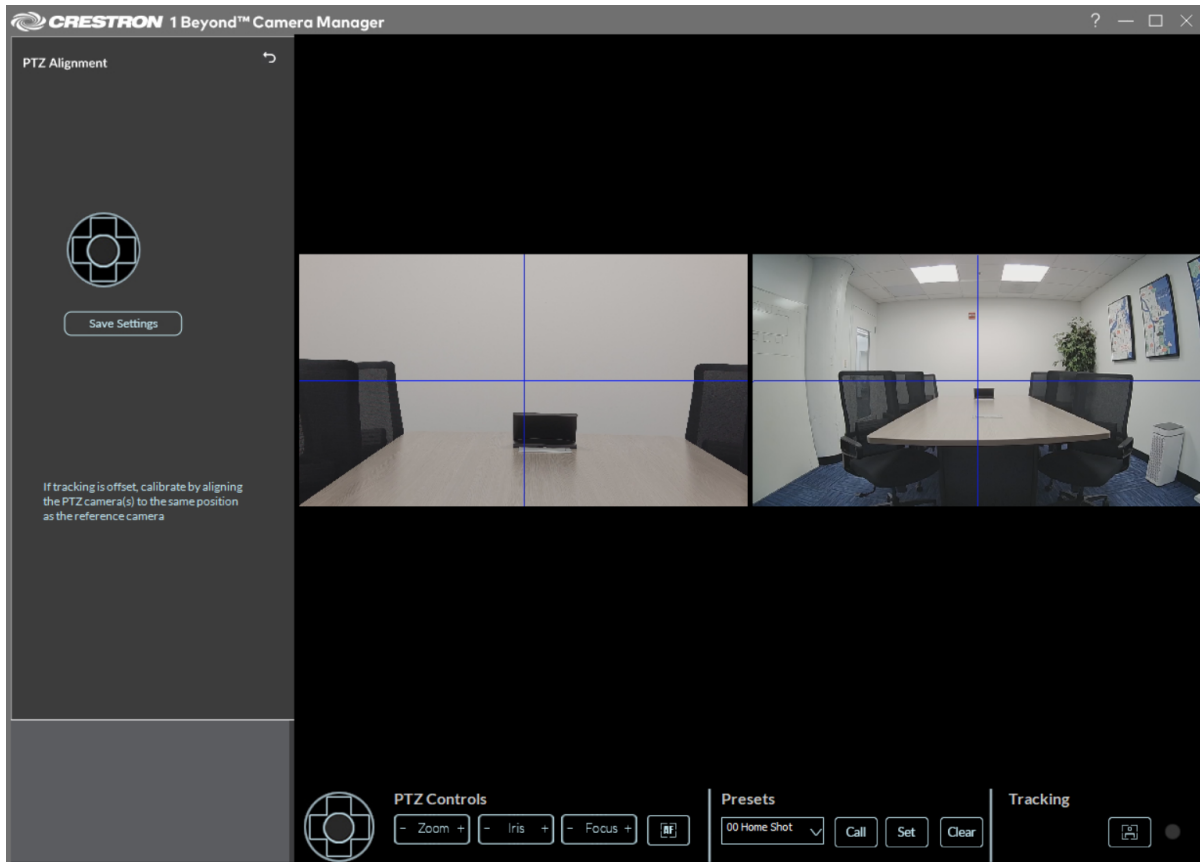

3. Use the PTZ lens controls in the **Settings** panel to move the PTZ video feed's blue crosshair into the same position as the wide-angle feed's crosshair. For best results, place an object that can be seen in both camera feeds as a point of reference for the blue crosshairs.

NOTE: There will be a slight parallax error (a displacement between the positions of the PTZ camera and wide-angle reference camera) when performing the step above. This behavior is expected.

4. Once the blue crosshairs in the PTZ video feed and the wide-angle feed are aligned, select **Save Settings** to confirm the changes.

NOTE: For IV-CAM-I12D-B cameras, steps 3 and 4 need to be performed for both PTZ 1 and PTZ 2 cameras.

5. Select the back arrow on the left side of the software to exit the PTZ Alignment interface.

Audio Correction (IV-CAM-I12D-B Only)

To ensure the best speaker tracking performance, perform a recalibration of the spacial audio detection within the wide-angle reference camera. When the spacial audio detection is misaligned within the wide-angle reference camera, speaker tracking camera shots may not be centered.

To correct the spacial audio detection in relation to the static wide-angle camera:

1. Open the **Tracking Zones** tab.
2. Select **PTZ Alignment** in the top left of the **Tracking Zones** menu.

Select PTZ Alignment

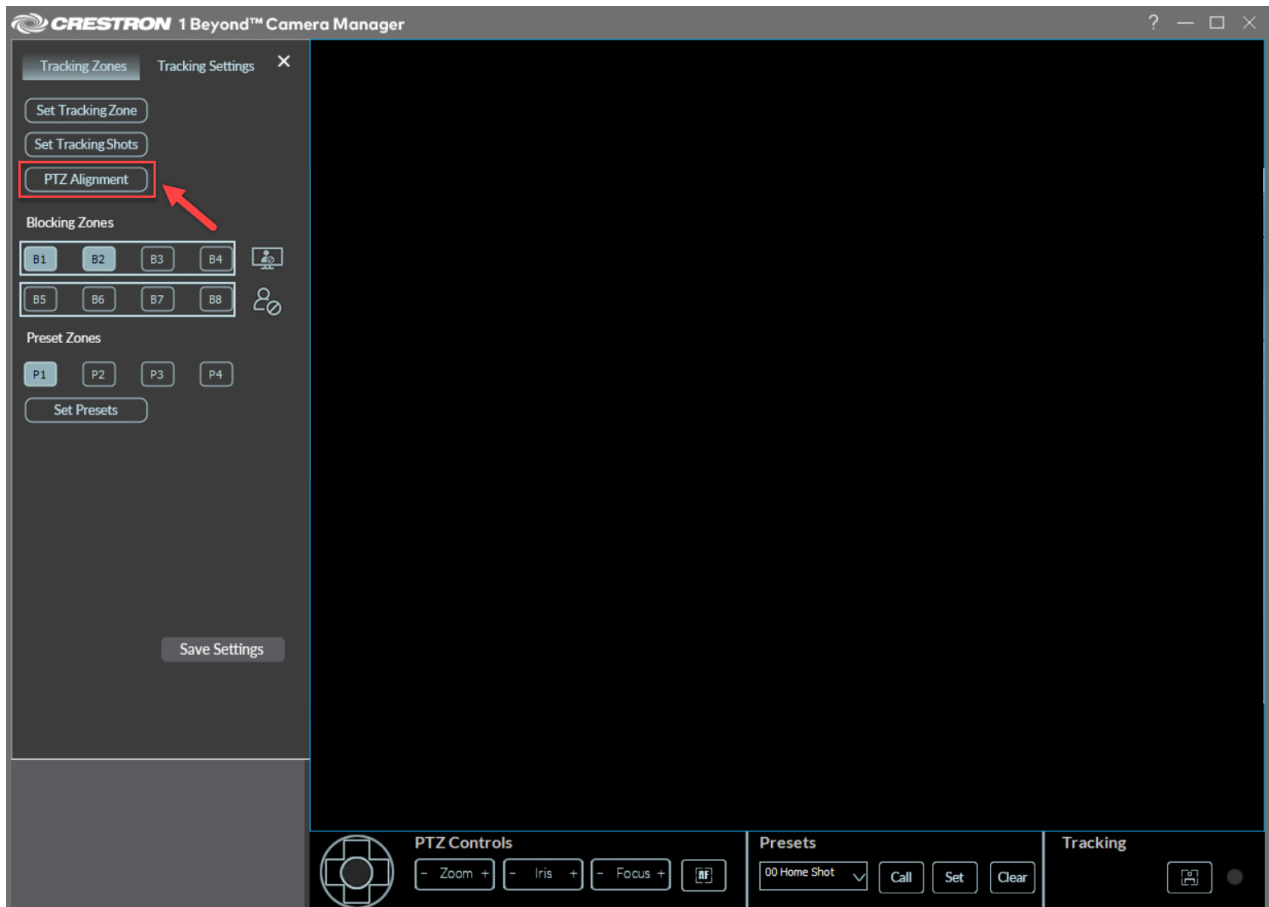

A window is displayed showing the PTZ's video feed and wide-angle camera's video feed overlaid with a blue crosshair.

PTZ Alignment Menu

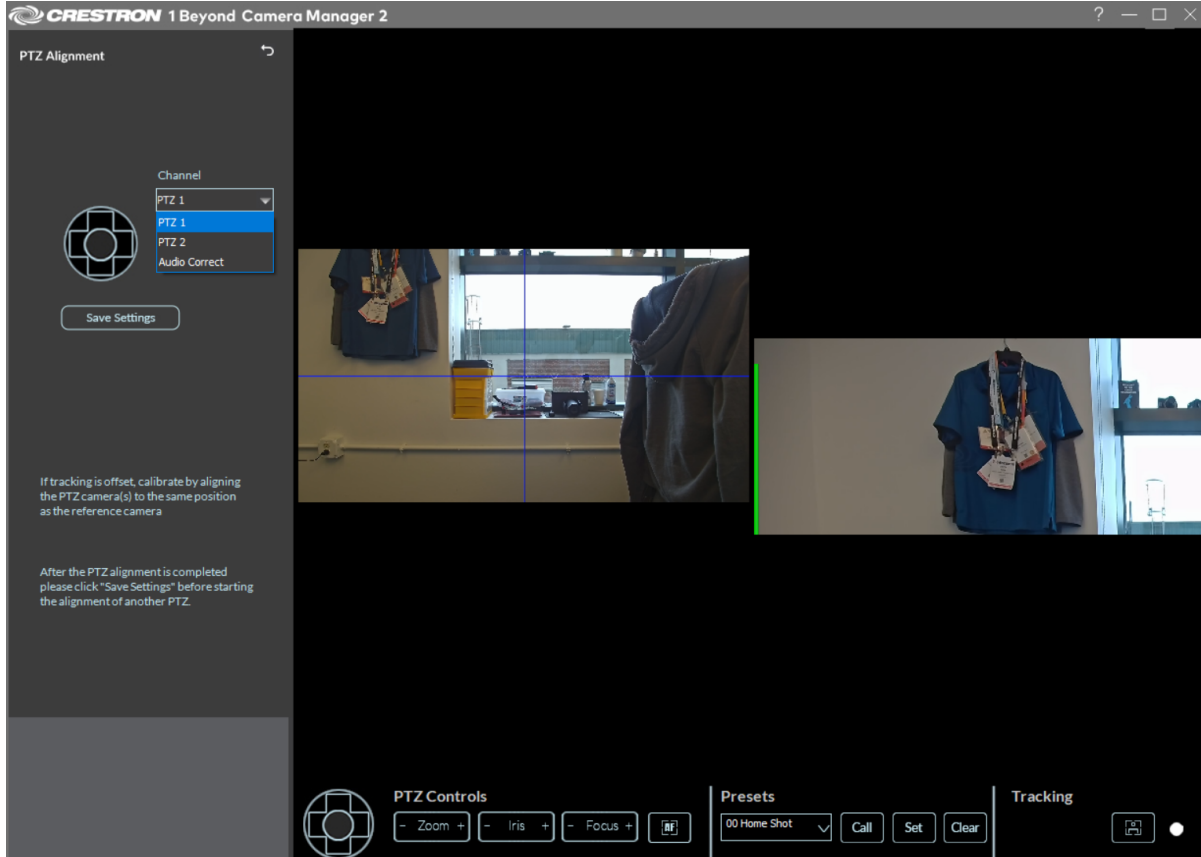

3. Select the **Channel** drop-down menu, then navigate to **Audio Correct**. A green Direction of Audio (DoA) bar appears on the reference camera feed. The DoA bar indicates where audio is being detected within the camera feed.
4. Have someone stand in front of the IV-CAM-I12D-B camera and continuously speak. The DoA bar moves to the perceived audio location within the camera feed. If the DoA bar is not aligned with the speaking participant, use the PTZ lens controls in the **Settings** panel to adjust the position of the DoA bar in the camera feed accordingly.
5. Once the DoA bar in the camera feed is aligned with the speaking participant, select **Save Settings** to confirm the changes.
6. Select the back arrow on the left side of the software to exit the PTZ Alignment interface.

Blocking Zones

Set **Blocking Zones** within the **Tracking Zone** to prevent unwanted objects from triggering the camera's facial detection. **Blocking Zones** are indicated in the video frame as red boxes.

NOTE: **Blocking Zones** are set per camera's mode. When the camera switches its intelligent function, the **Blocking Zones** set for that specific camera mode apply. Ensure that **Blocking Zones** are set for all desired camera modes. For more information on changing the camera's mode, refer to [Change the Camera Mode on page 142](#).

To draw a **Blocking Zone**:

1. Select one of the options underneath the **Blocking Zones** header. When an option is selected, the cursor moves into the video frame.

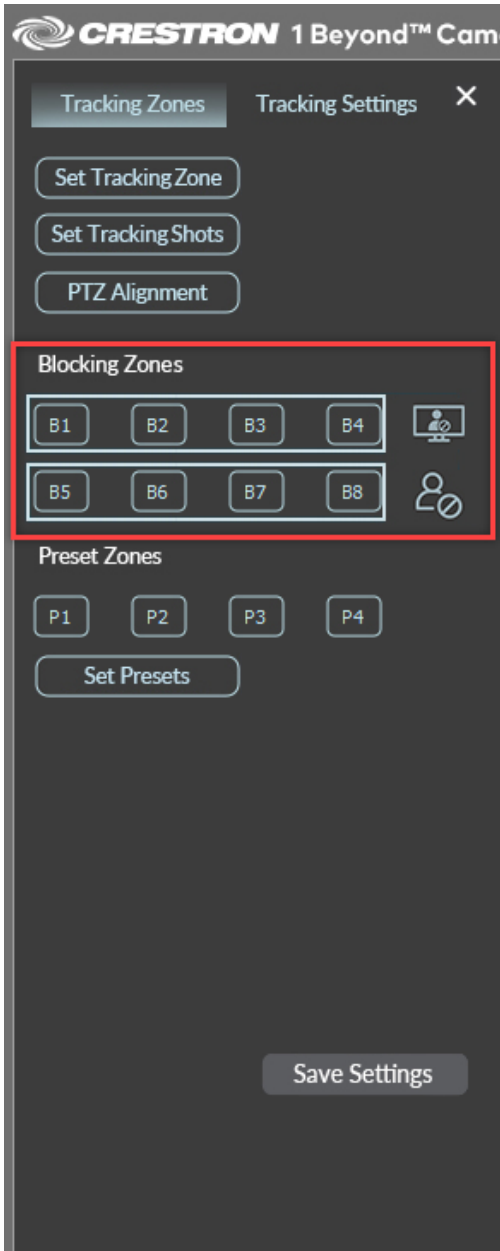

Blocking Zones B1 through **B4** are for blocking displays, windows, and projection screens.



Blocking Zones B5 through **B8** are for blocking participants.



2. Press and hold the cursor over the location in the video frame where the **Blocking Zone** should begin. Then, drag the cursor to draw the **Blocking Zone**.

Note the following guidelines when configuring **Blocking Zones**.

- **Blocking Zones** are only active within the **Tracking Zone**.
- Ensure that there is space on the edges of the **Tracking Zone** for a presenter to enter. Covering an edge of the **Tracking Zone** with a **Blocking Zone** causes the presenter to be not tracked.
- There is no padding around the edges of **Blocking Zones**, they behave precisely as they are drawn.
- **Blocking Zones B1 - B4**: Displays must be turned off and participants are required to be out of the camera's FOV when drawing the **Blocking Zone**.
- **Blocking Zones B5 - B8**: Do not block an entire section of the **Tracking Zone**. This could cause the camera to lose the presenter if they remain in the blocked area for too long.

3. Release the cursor to finish the **Blocking Zone**. Refer to the images below for an examples.

In this example, the Blocking Zone is placed on the left side of the Tracking Zone (green box) over the door. This prevents people entering or leaving the room from triggering the camera's facial detection. For more information about drawing a Tracking Zone, refer to [Set the Tracking Zone on page 193](#).

Participant Blocking Zone

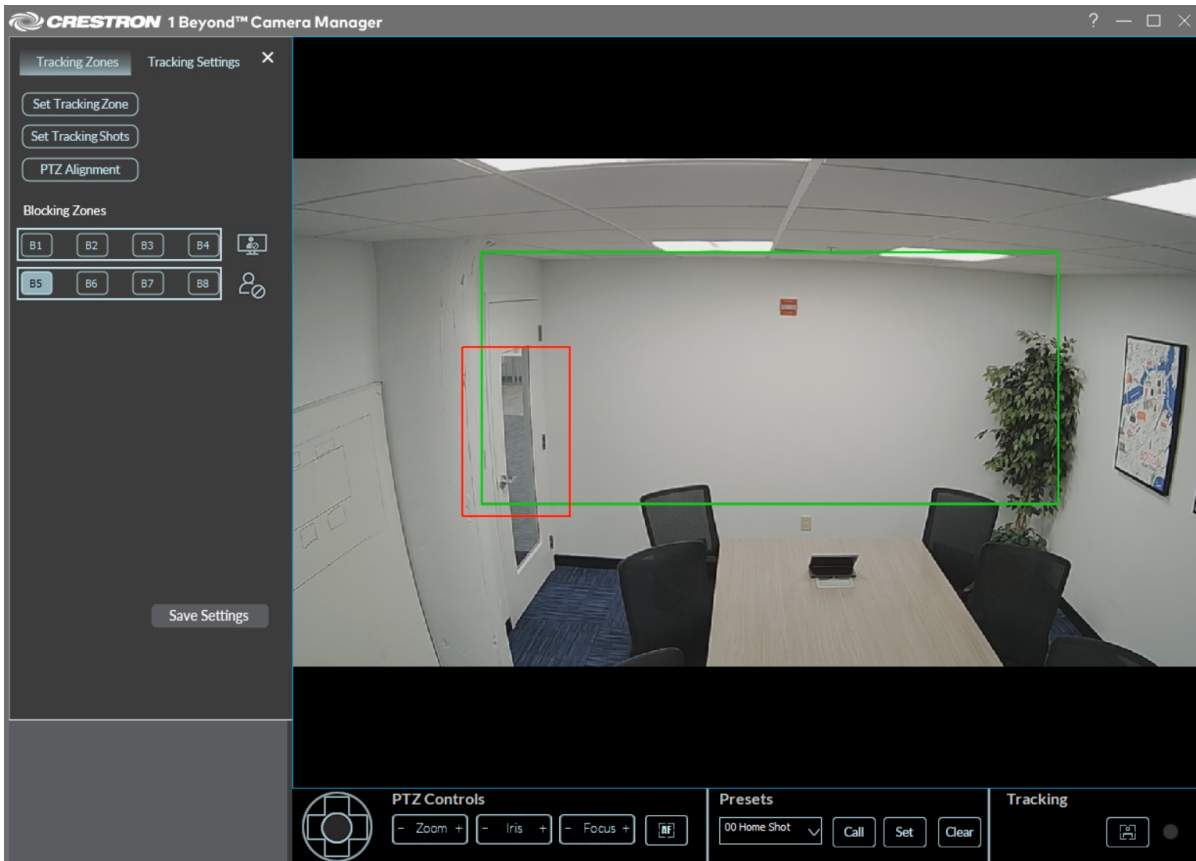

In this example, there are two Blocking Zones (red boxes) over the displays within the Tracking Zone (green box). These Blocking Zones prevent the displays from triggering the camera's facial detection, while still allowing the camera to detect motion in the area underneath the displays. There is also a Preset Zone (blue box) on the right side of the Tracking Zone, which switches the camera to a predefined camera shot after someone enters the zone. For more information about drawing a Preset Zone, refer to [Preset Zones on page 210](#).

Display Blocking Zone

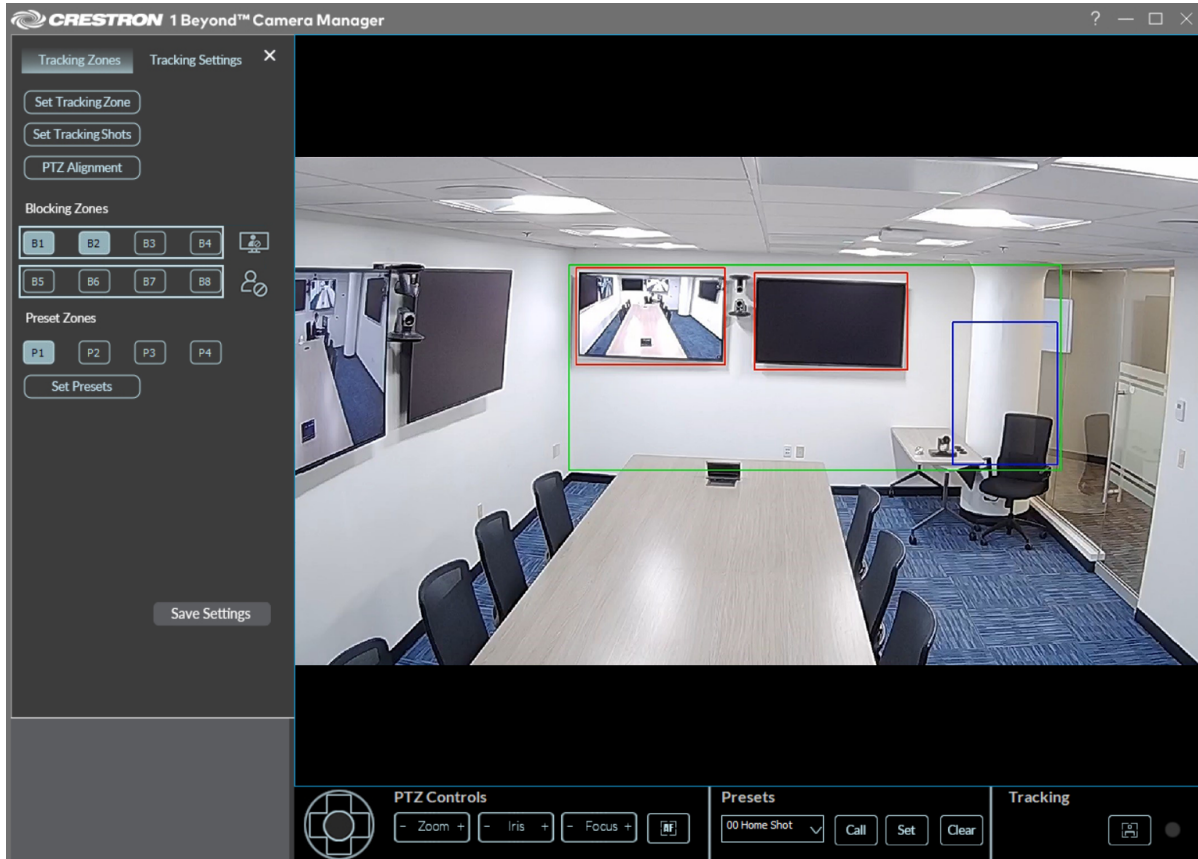

4. Once the **Blocking Zones** are set, select **Save Settings**.

NOTE: Tracking must be restarted for **Blocking Zones** to operate properly after configuring.

The **Blocking Zones** are now configured to ignore the defined areas.

Preset Zones

NOTE: **Preset Zones** are only available for the IV-CAM-I20.

Set **Preset Zones** within the video frame to prioritize a preconfigured camera shot in a defined area. The IV-CAM-I20 camera automatically centers in on a **Preset Zone** when a participant is detected within it, regardless of the current presenter tracking in the **Tracking Zone**. **Preset Zones** are indicated in the video frame as blue boxes. Up to four **Preset Zones** can be configured.

Complete the following procedure to draw and configure a **Preset Zone**.

1. Select one of the options under **Preset Zones** header. When an option is selected, the cursor moves into the video frame.

Preset Zones

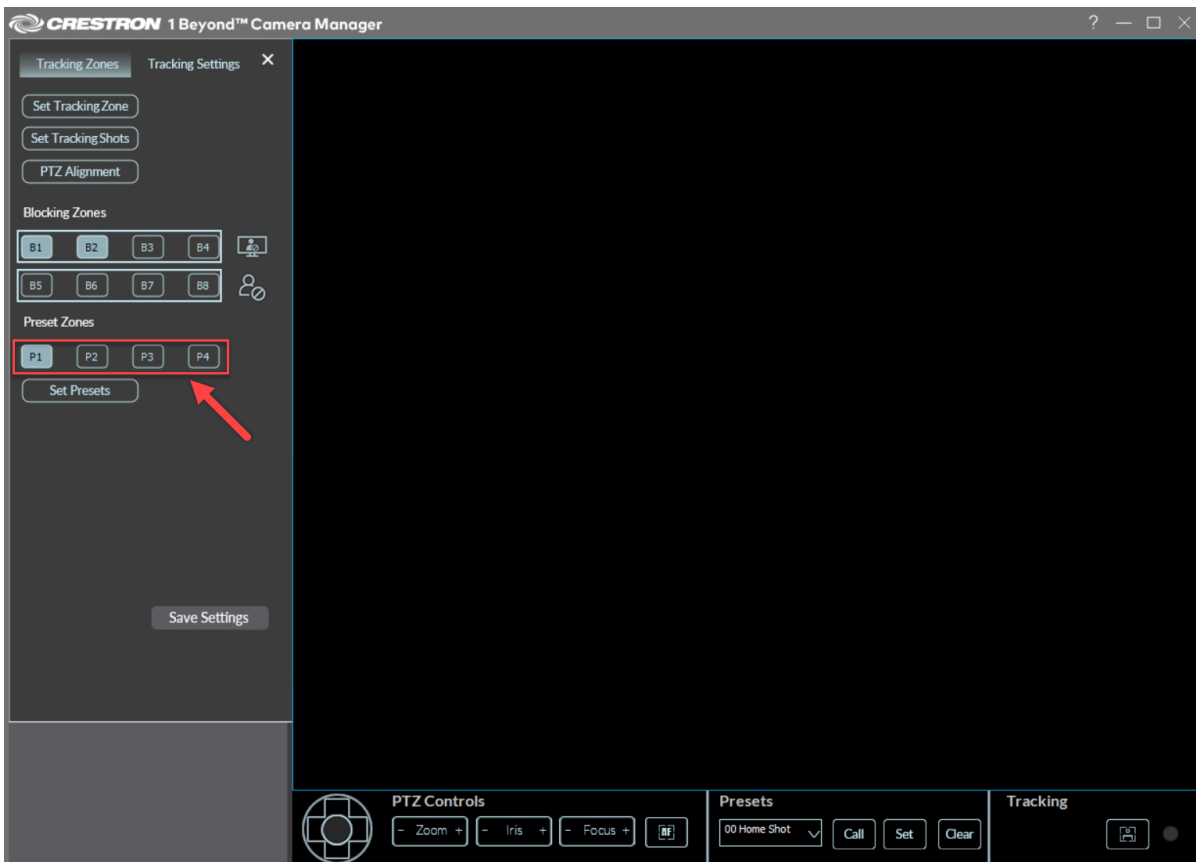

2. Press and hold the cursor over the location in the video frame where the **Preset Zone** should begin. Then, drag the cursor to draw the **Preset Zone**.

3. Release the cursor to finish the **Preset Zone**. Refer to the image below for an example.

In this example, there is a Preset Zone (blue box) on the right side of the Tracking Zone (green box), which when a participant enters it, makes the camera switch to a predefined camera shot. There are also two Blocking Zones (red boxes) over the displays within the Tracking Zone.

- For more information about drawing a Tracking Zone, refer to [Set the Tracking Zone on page 193](#).
- For more information about drawing a Blocking Zone, refer to [Blocking Zones on page 205](#).

Preset Zone Example

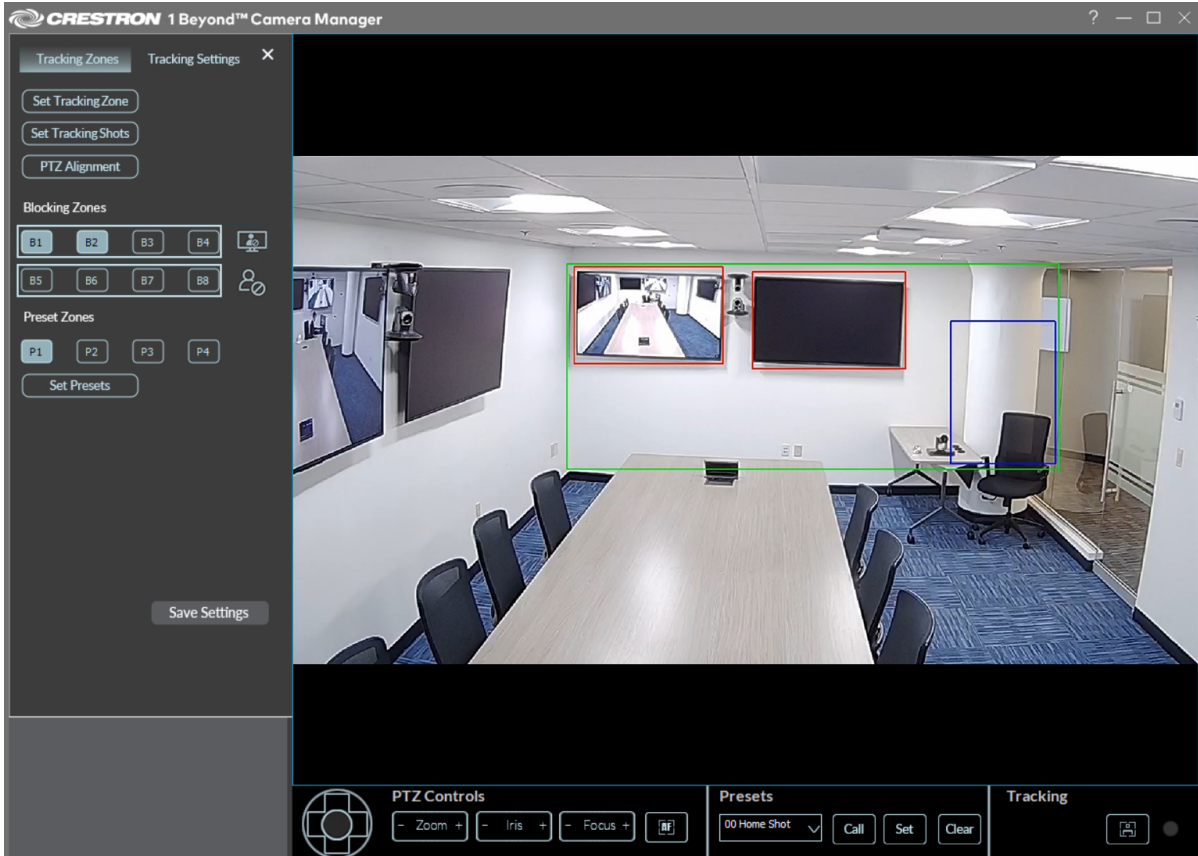

4. Select **Set Presets**. The **Set Preset Zones** menu appears.

Set Presets

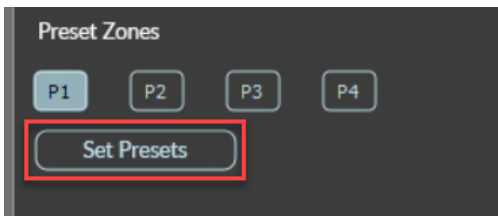

Preset Zones Menu

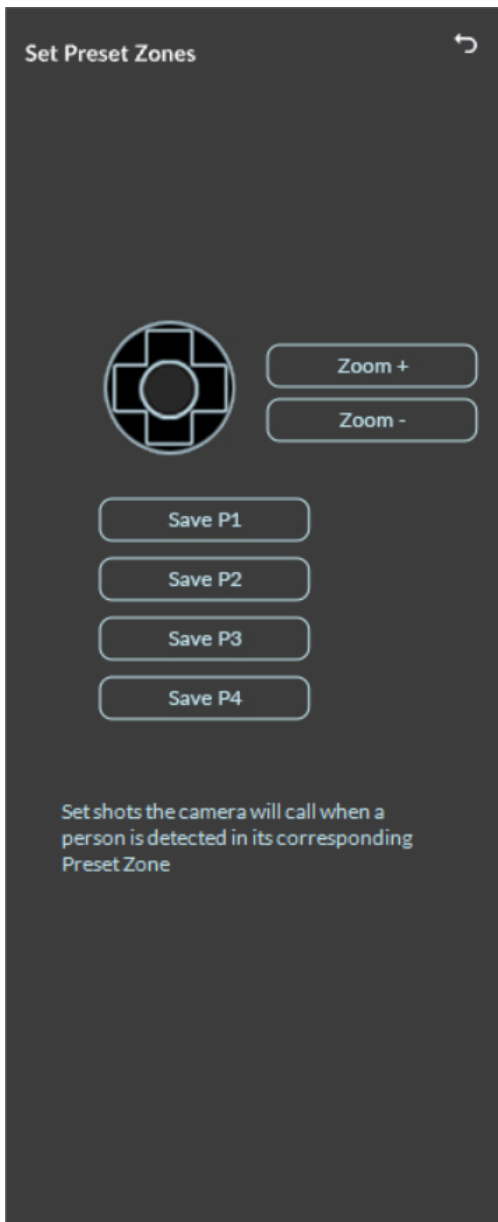

5. Use the navigation pad to pan and tilt the PTZ camera. The left and right buttons pan the camera, and the up and down buttons tilt the camera.



Use **Zoom +** and **Zoom -** to zoom the PTZ camera shot in or out.

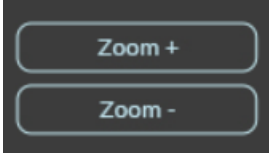

6. Select **Save** to set the camera shot for the **Preset Zone**. When the **Preset Zone** is activated, the its associated camera shot is displayed on the video feed.

NOTE: Ensure that the **Save** button number corresponds with the **Preset Zone** selected. **Save P1** is the camera shot displayed when **Preset Zone P1** is activated, **Save P2** is the camera shot for **Preset Zone P2**, and so forth.

7. Once the **Preset Zone** camera shots are set, select the back arrow button in the top right of the **Set Preset Zones** menu to return to the **Tracking Zones** menu.
8. Select **Save Settings** to save the **Preset Zones**.

Zone Profiles

NOTE: This feature is only available with IV-CAM-I20 series cameras.

Zone profiles allow IV-CAM-I20 series cameras to switch between up to four different intelligent zone configurations. This feature is useful for when an IV-CAM-I20 camera is used in a multi-purpose space where Tracking Zones, Blocking Zones, and Preset Zones configurations are required for different areas.

Complete the following procedure to configure Zone Profiles:

1. Select the **Tracking** button on the desired camera in the Camera List.

Tracking Button

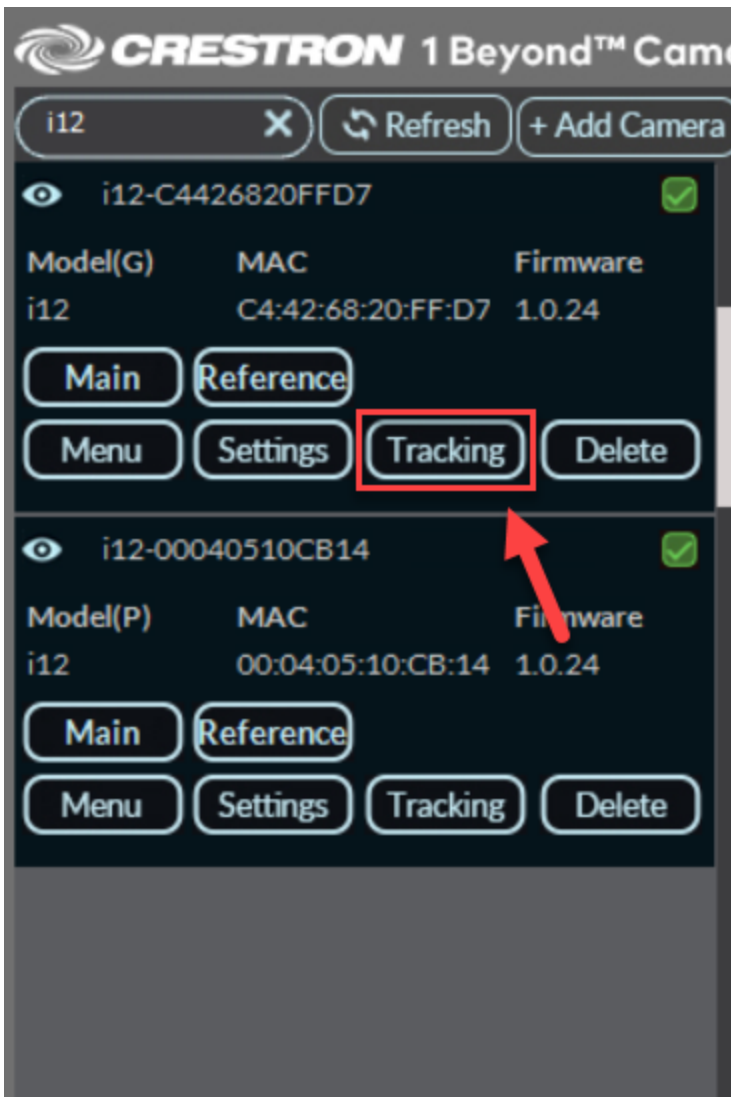

The Tracking Menu is displayed.

Tracking Menu

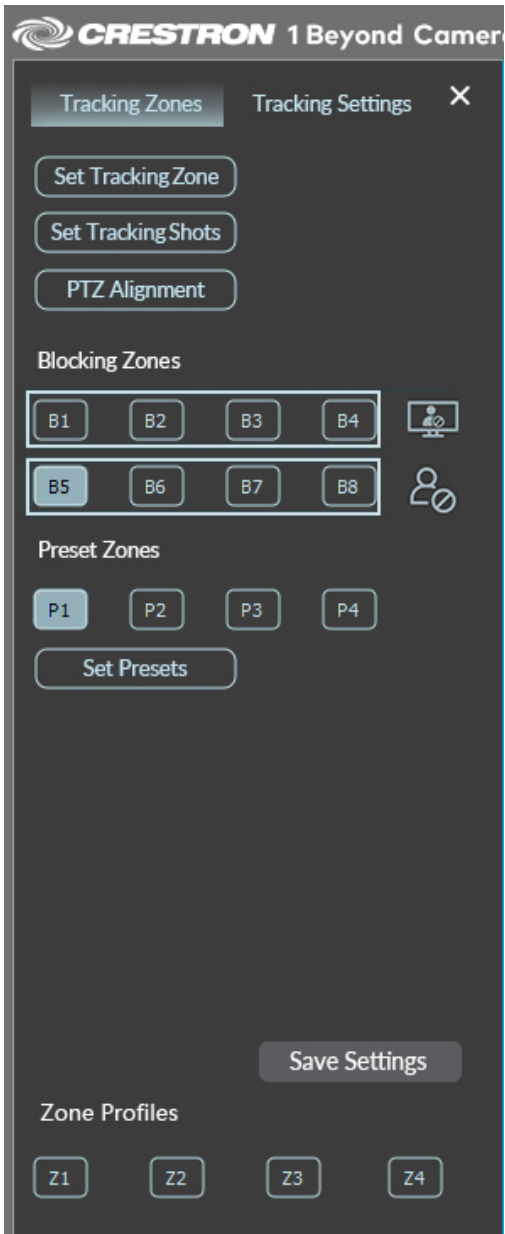

- At the bottom of the **Tracking Zones** tab, select one of the following **Zone Profiles**:

Zone Profiles

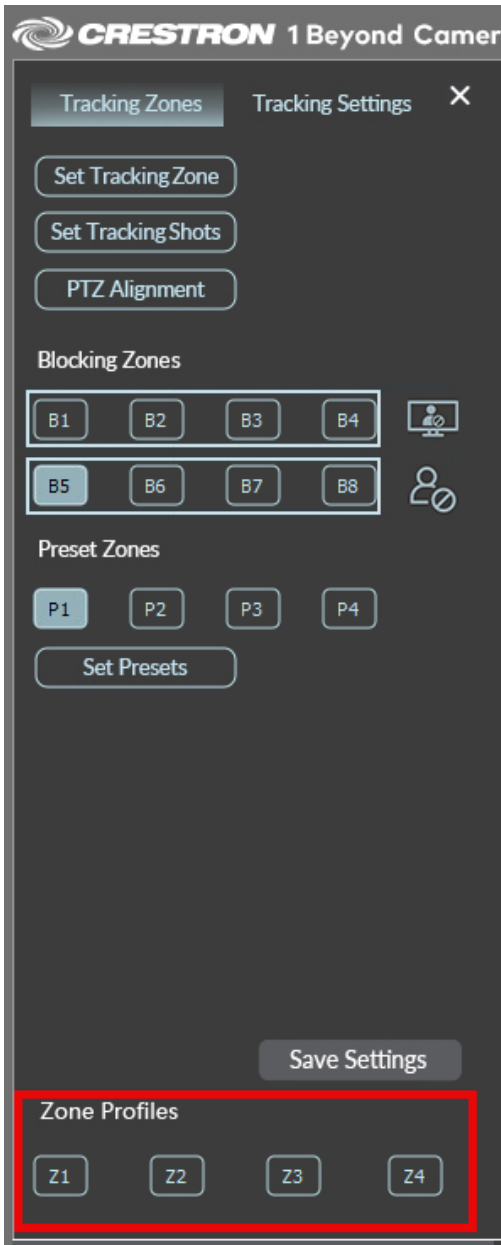

Zone Profile Selections

Zone Profile Designation	Tracking Zone Profile Configuration
Z1	Tracking Zone Profile 1 (default Tracking Profile)
Z2	Tracking Zone Profile 2
Z3	Tracking Zone Profile 3
Z4	Tracking Zone Profile 4

When the Zone Profile is selected, the i20 camera switches to its configured intelligent features (Tracking Zone, Blocking Zones, Preset Zones, **Home Shot (Preset 0)**, and **Tracking Shot (Preset 1)**). If they have not been configured yet, proceed to step 3.

3. Configure the intelligent features for the selected Zone Profile. For more information on configuring the intelligent features, refer to [Tracking Menu on page 191](#)

The Tracking Profile is now configured. Repeat the above procedure for any additional Zone Profile requirements.

TIP: During camera operation, a reserved camera preset can be called to switch the Zone Profile. Refer to the following table for reserved Zone Profile presets:

Reserved Tracking Profile Presets

Preset	Function
105	Zone Profile 1
106	Zone Profile 2
107	Zone Profile 3
108	Zone Profile 4

For more information on calling camera presets, refer to [Presets on page 158](#).

Tracking Settings

The **Tracking Settings** menu is used to define specific camera settings that affect how intelligent functions (Group Framing, Group Tracking, Presenter Tracking, and Speaker Tracking) operate. To access the **Tracking Settings**, select the **Tracking Settings** tab within the **Tracking** menu.

Select Tracking

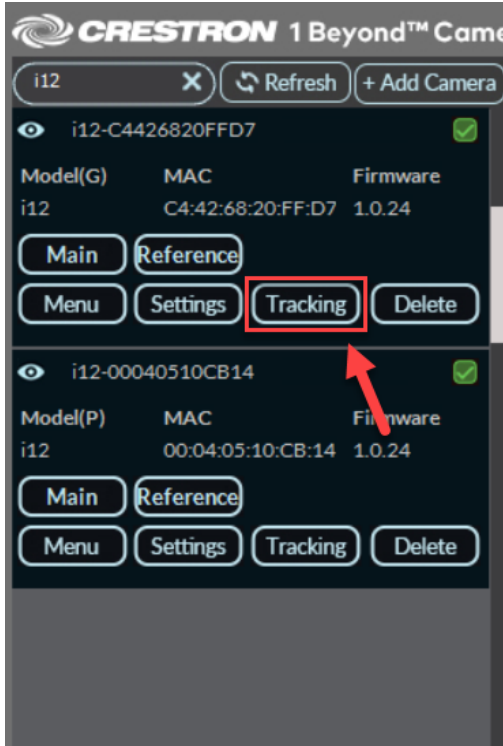

Select Tracking Settings



NOTE: The **Tracking Settings** menu contains different settings depending on whether an i12, i20, or i12D camera is being configured. Additionally, if the i12 or i12D camera is in group framing mode, it contains different settings. For more information on changing the camera mode, refer to [Change the Camera Mode on page 142](#).

The following image shows the IV-CAM-I20 **Tracking Settings** as an example.

Tracking Settings

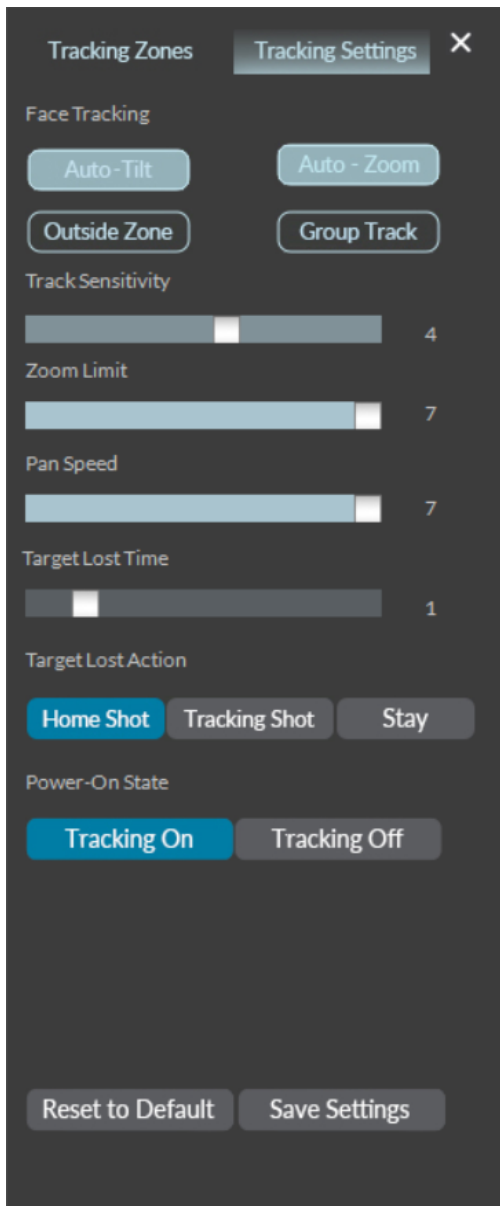

NOTE: For IV-CAM-I20 cameras, ensure that the Room Size is set to the desired option before proceeding. For more information about changing the Room Size for the camera, refer to [On-Screen Display \(OSD\) on page 162](#).

This section provides the following information:

- [Presenter Tracking Settings](#)
- [Group Framing Settings](#)
- [Speaker Tracking Settings](#)
- [PIP Position](#)
- [PIP Size](#)

Presenter Tracking Settings

NOTE: Presenter Tracking settings are only available for the IV-CAM-I20 and IV-CAM-I12 set to **Presenter** mode. For more information on switching a camera's mode, refer to [Change the Camera Mode on page 142](#)

Refer to the following sections for information on the available Presenter Tracking settings.

Presenter Tracking Settings

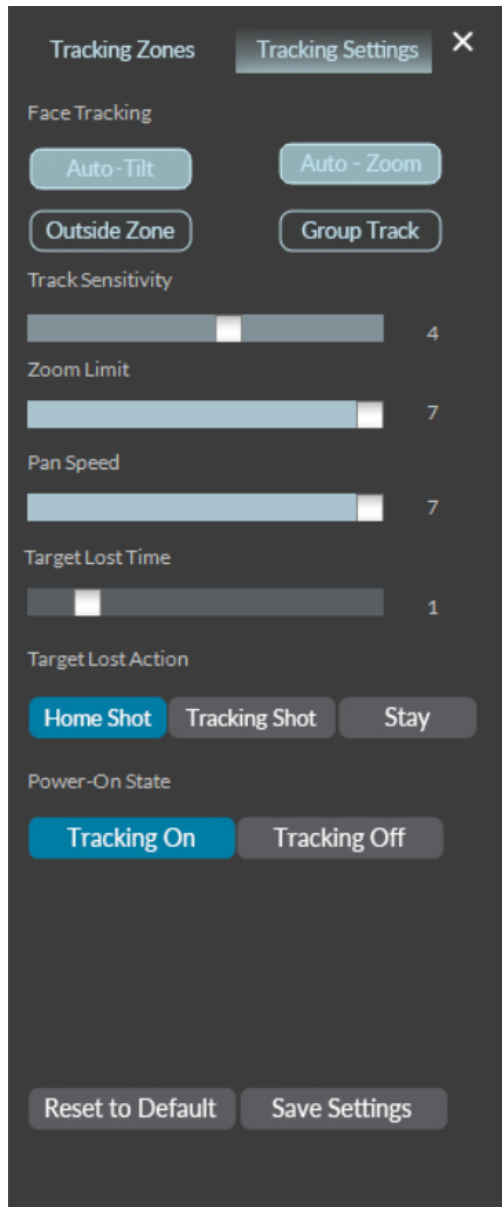

Auto-Tilt

When enabled, the camera will tilt up or down once locked onto a presenter.

Auto Zoom

When enabled, the camera will automatically zoom in or out as the tracked subject moves closer to or away from the camera.

Outside Zone

When enabled, the camera keeps tracking a presenter that it has locked onto as they exit the **Tracking Zone** but remain in the wide-angle reference camera's FOV (field of view). For more information about Tracking Zones, refer to [Set the Tracking Zone on page 193](#).

Group Track

NOTE: Group Tracking is only available for the IV-CAM-I20.

When enabled, the camera fits all participants into the frame and tracks the presenters within the **Tracking Zone**. When disabled, the camera only tracks one presenter at a time. For more information about Tracking Zones, refer to [Set the Tracking Zone on page 193](#).

Track Sensitivity

Use the slider to determine how sensitive the wide-angle camera detection is within the tracking zone. Lower this setting if the camera gets distracted by lighting changes or shadows.

Target Lost Time

Use the slider to determine how long the camera waits before returning to the **Target Lost Action** once the participant leaves the **Tracking Zone**. For more information about Tracking Zones, refer to [Set the Tracking Zone on page 193](#).

Zoom Limit

Use the slider to determine the maximum amount of zoom applied when the tracked presenter moves further into the background.

Pan Speed

Use the slider to adjust the speed of pan movement during tracking. Increase **Pan Speed** if presenters tend to be more active.

Target Lost Action

Determines whether the camera returns to the **Home Shot (Preset 0)**, **Tracking Shot (Preset 1)**, or stays at its current position when no presenter is being tracked. For more information on setting the **Home Shot (Preset 0)** and **Tracking Shot (Preset 1)**, refer to [Set the Tracking Shots on page 196](#).

Power On State

Determines whether Presenter Tracking is enabled or disabled when the camera is powered on.

Group Framing Settings

NOTE: Group Framing settings are only available for the IV-CAM-I12 or IV-CAM-I12D-B set to **Group** mode. For more information on switching a camera's mode, refer to [Change the Camera Mode on page 142](#)

Refer to the following sections for information on the available Group Framing settings.

Group Framing Settings

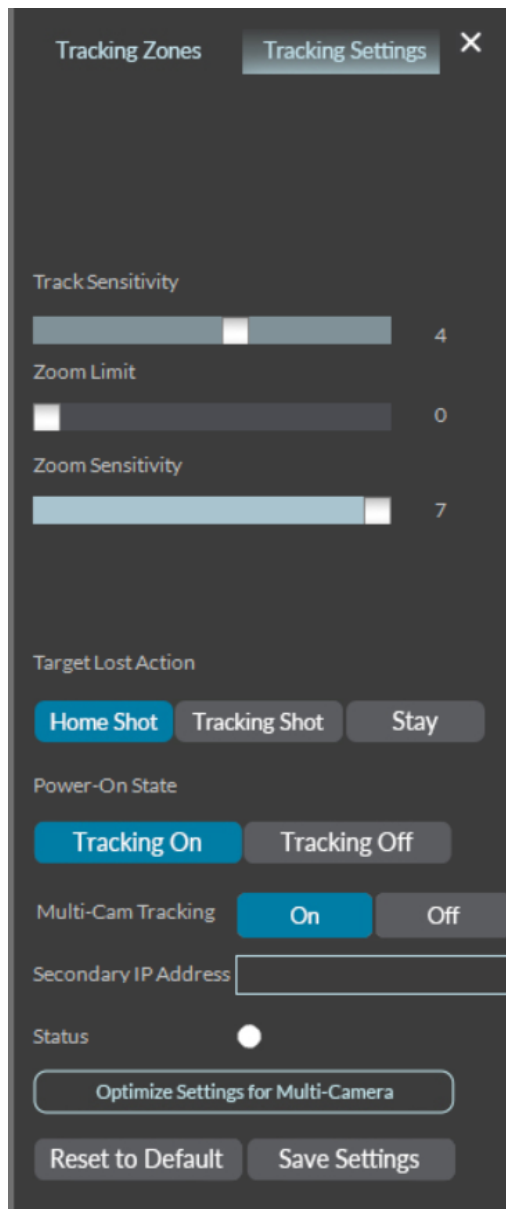

Track Sensitivity

Use the slider to determine the tracking sensitivity of the wide-angle reference camera when participants leave the edges of Group Framed camera shot. Lower this setting if the camera is frequently readjusting the Group Framed camera shot when participants are moving.

Zoom Sensitivity

Use the slider to determine how tightly the PTZ camera frames participants. Use a higher value for tight group framed camera shots and use a lower value for wide group framing camera shots.

Zoom Limit

Use the slider to determine the maximum amount of zoom applied when the tracked subjects moves further into the background.

Target Lost Action

Determines whether the camera returns to the **Home Shot (Preset 0)**, **Tracking Shot (Preset 1)**, or stays at its current position when no participants are detected.

Power On State

Determines whether Group Framing is enabled or disabled when the camera is powered on.

Intelligent Switching

Intelligent Switching settings are located in the Group Framing settings. For more information about configuring a Intelligent Switching solution, refer to [Intelligent Switching on page 232](#).

Intelligent Switching Settings

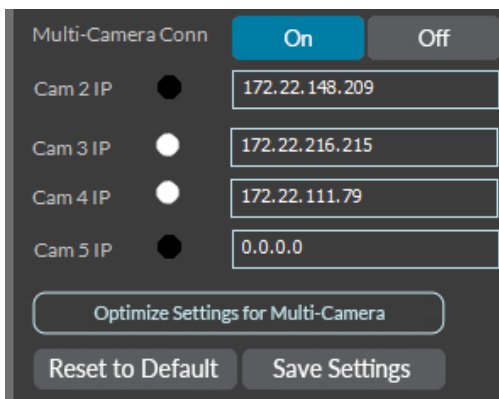

The screenshot shows the Intelligent Switching Settings interface. At the top, there is a toggle for 'Multi-Camera Conn' with 'On' selected. Below this are four rows for camera IP addresses, each with a radio button and a text input field. The IP addresses are: Cam 2 IP (172.22.148.209), Cam 3 IP (172.22.216.215), Cam 4 IP (172.22.111.79), and Cam 5 IP (0.0.0.0). At the bottom, there are three buttons: 'Optimize Settings for Multi-Camera', 'Reset to Default', and 'Save Settings'.

Camera	IP Address
Cam 2 IP	172.22.148.209
Cam 3 IP	172.22.216.215
Cam 4 IP	172.22.111.79
Cam 5 IP	0.0.0.0

Speaker Tracking Settings

NOTE: Speaker Tracking settings are only available for the IV-CAM-I12D-B when set to Speaker Tracking mode.

Refer to the following sections for information on the available Speaker Tracking settings.

Speaker Tracking Settings

Tracking Zones Tracking Settings ✕

Tracking Mode: Speaker Tracking

Track Sensitivity: 3

Track Speed: 3

Target Lost Time: 3

Conversation Cycle: 1

Conversation Length: 2

Pause Delay: 5

Target Lost Action: Home Shot, Tracking Shot, Stay

Power-On State: Tracking On, Tracking Off, Home Shot

Face Offset: High, Middle, Low

Frame Padding: Tight, Wide

Speaker Tracking Mode: Single, Conversation

Standby Action: Group Framing, Stay, Reference

Reset to Default Save Settings

⇌

Tracking Mode

Use the **Tracking Mode** drop-down menu to set the intelligent function of the camera as either **Group Framing** or **Speaker Tracking**. For more information about **Group Framing**, refer to [Group Framing Settings on page 224](#)

Track Sensitivity

Use the slider to determine the tracking sensitivity of the wide-angle camera when detecting a speaking participant. Lower this setting if the camera is switching between speaking participants too frequently.

Track Speed

Use the slider to adjust the speed of PTZ camera movement during tracking.

Target Lost Time

Use the slider to determine how long the camera waits before returning to the **Target Lost Action** once no speaking participants are detected.

Conversation Cycle

Use the slider to determine how many camera switches need to occur between two speaking participants before Conversation Mode begins. For more information about Conversation Mode, refer to [Speaker Tracking Mode on page 228](#).

Conversation Length

Use the slider to set the length of time that Conversation Mode remains in the camera output while only one participant is actively speaking. Once the Conversation Length is exceeded, the camera shot transitions to a single shot of the last active speaking participant. For more information about Conversation Mode, refer to [Speaker Tracking Mode on page 228](#).

Pause Delay

Use the slider to determine the amount of time before the **Standby Action** occurs. The **Pause Delay** condition can be met either through silence in front of the camera, or when active Audio Reference is sent to the camera. For more information about **Standby Action**, refer to [Standby Action on page 228](#).

Target Lost Action

Determines whether the camera returns to the **Home Shot (Preset 0)**, **Tracking Shot (Preset 1)**, or stays at its current position when no active speaking participant is heard. For more information on setting the **Home Shot (Preset 0)** and **Tracking Shot (Preset 1)**, refer to [Set the Tracking Shots on page 196](#).

Power On State

Determines whether Speaker Tracking is enabled or disabled when the camera is powered on.

Face Offset

Select **High**, **Middle**, or **Low** to set the placement of the speaking participant's face in the camera shot.

Frame Padding

Determines the amount of space around the speaking participant in the camera shot. Select **Tight** for a close up camera shot, or select **Wide** for a more zoomed out shot.

Speaker Tracking Mode

Select **Single** to show only one speaking participant in the camera shot. Select **Conversation** to capture two active speaking participants within a side-by-side camera shot.

This shot is called after the system detects another speaking participant other than the current one. Once they speak back and forth for the amount of **Conversation Cycles** set, they appear on the output in a side-by-side camera shot. For more information about Conversation Mode settings, refer to [Speaker Tracking Settings on page 226](#).

NOTE: Conversation Mode is only available via the USB and HDMI outputs of the camera.

Standby Action

The **Standby Action** occurs when the conditions for **Pause Delay** are met. For more information about Pause Delay, refer to [Pause Delay on page 227](#).

Select **Group Framing** for a framed shot of all visible participants in front of the camera, **Stay** to remain on the last used camera shot, or **Reference** to show the reference camera's output.

Additional Settings

Select the double arrow button on the bottom of the **Tracking Settings** tab to expose additional settings.

Double Arrow Button

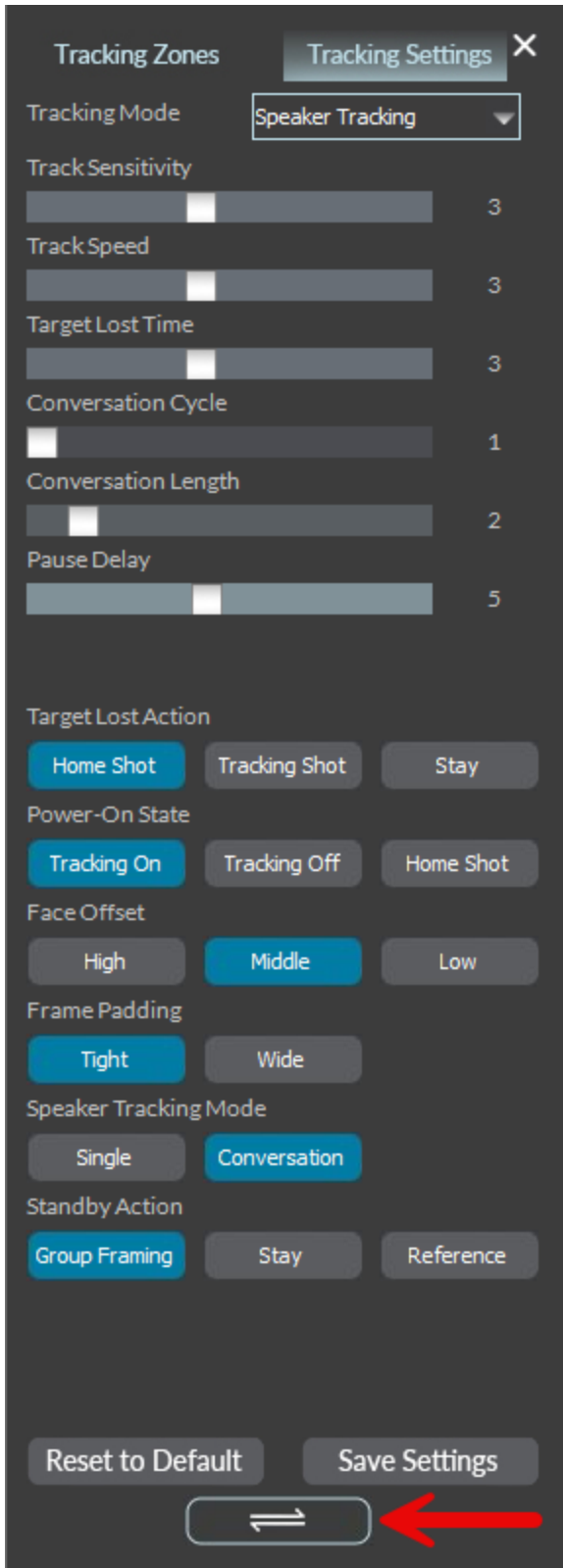

Additional Settings

The screenshot shows a dark-themed settings window titled "Tracking Settings" with a close button (X) in the top right corner. The window is divided into several sections:

- Tracking Zones:** A tab at the top left.
- Multi-Camera Conn:** A toggle switch currently set to "Off".
- Speaker Priority:** A toggle switch currently set to "Off".
- Cam 2 IP:** A radio button (selected) and a text input field containing "0.0.0.0".
- Cam 3 IP:** A radio button (selected) and a text input field containing "0.0.0.0".
- Cam 4 IP:** A radio button (selected) and a text input field containing "0.0.0.0".
- Cam 5 IP:** A radio button (selected) and a text input field containing "0.0.0.0".
- Optimize Settings for Multi-Camera:** A button below the IP address fields.
- Layout:** Two buttons: "Standard" and "PIP" (selected).
- PIP Position:** Four buttons: "Top Left" (selected), "Top Right", "Bottom Left", and "Bottom Right".
- PIP Size:** Three buttons: "Small", "Medium" (selected), and "Large".
- Reset to Default:** A button at the bottom left.
- Save Settings:** A button at the bottom right.
- Navigation:** A double-headed arrow button at the very bottom.

The following settings are available in the additional settings menu.

Intelligent Switching Settings

Multi-Camera Conn, **Speaker Priority**, and **Cam IP** settings are used for Intelligent Switching. To configure Intelligent Switching for the IV-CAM-l12D-B camera, refer to [Intelligent Switching on page 232](#).

Layout

Layout changes the Output of the camera to a video feed with different formatting. Select either of the following Layout options:

- **Standard:** Displays a full-screen camera shot in the Output.
- **PIP:** Displays a Picture-in-Picture (PIP) camera layout in the Output. A PiP layout uses the reference camera's feed in the selected corner, while showing the active PTZ camera as the full-screen video feed.

Refer to the sections below for **PIP** settings.

PIP Position

The reference camera's feed in the **PIP** layout can be moved to any of the corners of the **Output**. Select **Top Left**, **Top Right**, **Bottom Left**, or **Bottom Right** to move the reference camera's feed to the respective corner of the **Output**.

PIP Size

The size of the reference camera's feed in the **PIP** layout can be changed. Select **Small**, **Medium**, or **Large** to adjust the size of the reference camera's feed in the **Output**.

Intelligent Switching

Intelligent Switching utilizes up to five Crestron 1 Beyond cameras to switch between Group Framing, Presenter Tracking, and static camera shots. This is achieved by having a host camera (IV-CAM-I12 set to Group Framing or IV-CAM-I12D-B), alongside additional cameras connected on the network.

This section provides the following information:

- [Intelligent Switching Design](#)
- [Connection Requirements](#)
- [Intelligent Switching Output](#)
- [Visual Cue Intelligent Switching Configuration](#)
- [Custom Intelligent Switching Configuration](#)
- [Intelligent Switching Advanced Options](#)

Intelligent Switching Design

There are two configurations available for Intelligent Switching, both providing a different camera switching experience. Additionally, both of the configurations require different cameras, connection methods, and hardware.

Refer to the following sections for more information on the available Intelligent Switching configurations.

Visual Cue Intelligent Switching

Visual Cue Intelligent Switching utilizes an IV-CAM-I12 camera in Group Framing mode and up to four other Crestron intelligent cameras (IV-CAM-I12 and IV-CAM-I20 models) serving as Presenter Tracking cameras.

This configuration only requires the Crestron 1 Beyond Camera Manager 2 software for initial setup. For more information on this configuration, refer to [Visual Cue Intelligent Switching Configuration on page 236](#).

Custom Intelligent Switching

Custom Intelligent Switching utilizes an IV-CAM-I12 camera in Group Framing mode and up to four other Crestron 1 Beyond cameras (IV-CAM-P12/P20 models and IV-CAM-I12/I20 models).

This configuration requires the provided example module located on the respective camera product page and a control system. For more information on this configuration, refer to [Custom Intelligent Switching Configuration on page 242](#).

Connection Requirements

Before proceeding to the desired Intelligent Switching configuration, observe the following connection requirements for **Intelligent Switching**:

- All cameras that are used must be connected on the same network via an Ethernet cable.
- The host camera (IV-CAM-I12 set to Group Framing or IV-CAM-I12D-B) must be connected via USB into a conferencing codec such as a [Crestron Collab Compute](#).
 - The conferencing codec must be operating with a software compatible with MJPEG camera output.
- A laptop docking station cannot be used for video output.
- Intelligent Switching is not compatible with the SDI and HDMI video outputs.

Intelligent Switching Output

In Intelligent Switching configurations, the Group Framing camera's video feed is the default output. When a presenter enters the tracking zone of the Presenter Tracking camera, the video output of the Presenter Tracking camera is streamed through the Group Framing camera.

The Group Framing camera outputs either of the active video feeds via USB or through the camera's **Main Stream** in the Crestron 1 Beyond Camera Manager 2 software. For more information on accessing video feeds in the Crestron 1 Beyond Camera Manager 2 software, refer to [Accessing Camera Feeds on page 149](#).

Visual Cue Intelligent Switching Configuration

Visual Cue Intelligent Switching utilizes a host camera (IV-CAM-I12 set to Group Framing or IV-CAM-I12D-B) and up to four other Crestron intelligent cameras (IV-CAM-I12 and IV-CAM-I20) serving as Presenter Tracking cameras.

Camera switching in this configuration occurs based on visual cues:

- If a participant enters the Tracking Zone of one of the Presenter Tracking cameras, the video output switches to that camera.
 - If there are participants in two or more cameras' Tracking Zones, the higher numbered camera takes priority in the output. The order of camera priority is as follows (highest priority to lowest): camera 2, camera 3, camera 4, camera 5.
- If there are no participants in any Tracking Zones associated with Presenter Tracking cameras, the camera output switches to the host camera (IV-CAM-I12 set to Group Framing or IV-CAM-I12D-B).

To activate Visual Cue Intelligent Switching:

NOTE: Additional Presenter Tracking and Group Framing settings require configuration for **Intelligent Switching** to operate properly. For more information on Presenter Tracking and Group Framing settings, refer to [Tracking Settings on page 219](#).

1. Select **Tracking** on the host camera in the camera list to access the **Tracking** menu.

Tracking Button

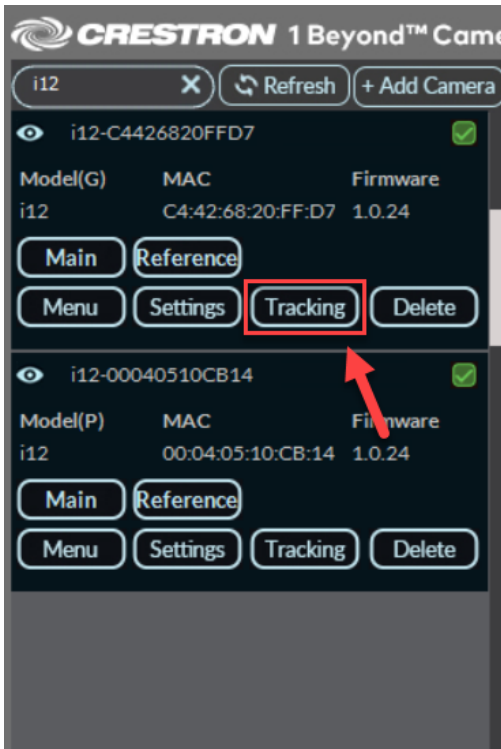

The Tracking Menu is displayed.

Tracking Menu

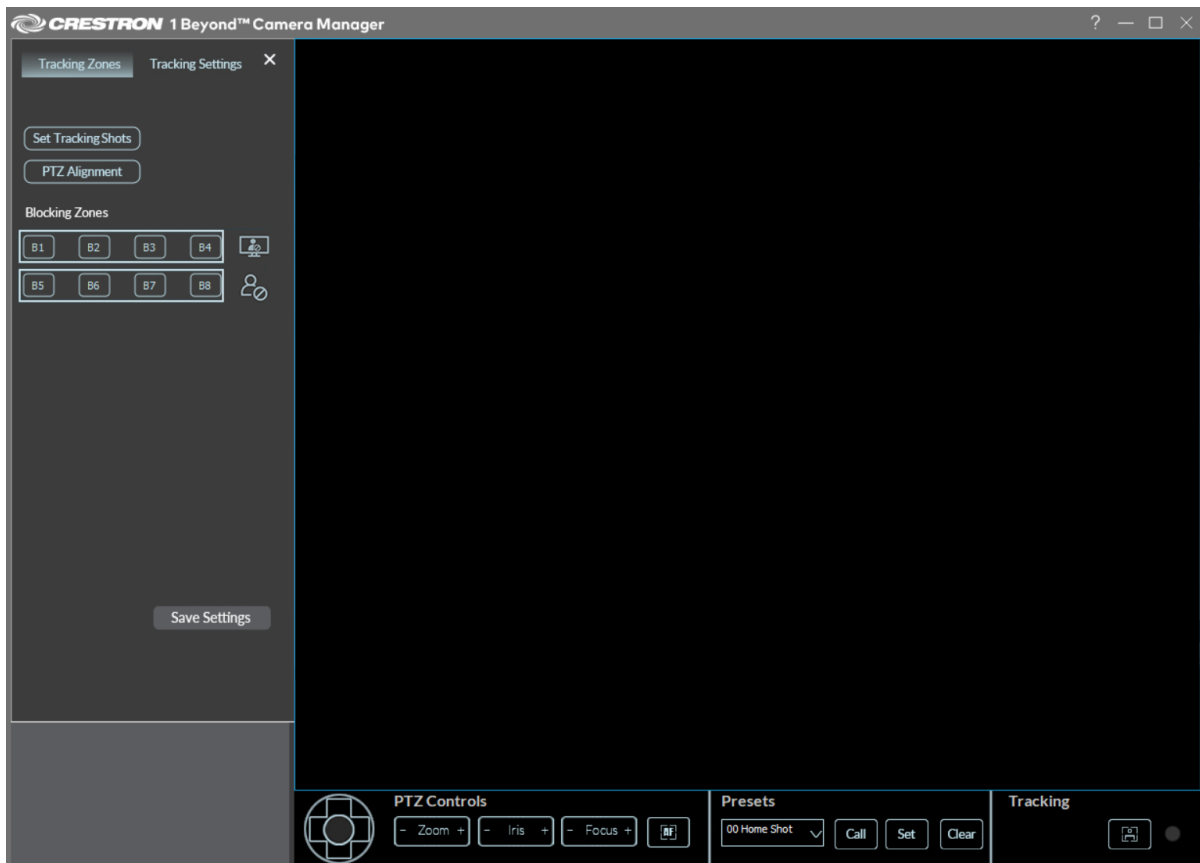

2. Select the **Tracking Settings** tab to access the **Tracking Settings**.
Select Tracking Settings



The **Tracking Settings** menu is displayed. The **Multi-Cam Tracking** settings are located at the bottom of the **Tracking Settings** menu.

Tracking Settings

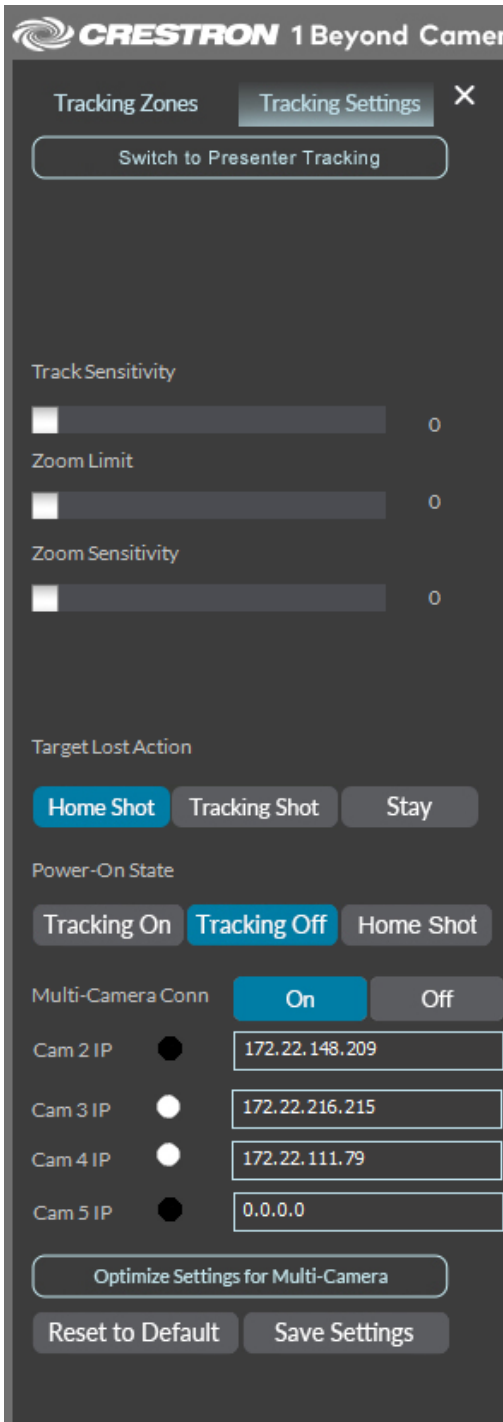

3. Enable **Multi-Cam Tracking** by selecting **On**.

Multi-Camera Tracking Settings

Multi-Camera Conn On Off

Cam 2 IP 172.22.148.209

Cam 3 IP 172.22.216.215

Cam 4 IP 172.22.111.79

Cam 5 IP 0.0.0.0

Optimize Settings for Multi-Camera

Reset to Default Save Settings

4. (IV-CAM-I12D-B in Speaker Tracking mode Only) Select **Speaker Priority** to have the speaker tracking camera shots take priority on the camera output.

Speaker Priority

Multi-Camera Conn On Off

Speaker Priority On Off

5. In the **Cam 2 IP** text field, enter the IP address of the Presenter Tracking camera (IV-CAM-I12 camera set to Presenter Tracking mode or an IV-CAM-I20 camera). For more information on setting an IP address for a camera, refer to [Set a Static IP Address on page 135](#).

NOTE: The light indicator next to the IP address text field displays the camera connection status. A white light indicates that the camera is connected and operational. If the light is black, the camera is either disconnected or not operational.

6. If more than two cameras are used in the Intelligent Switching configuration, enter the additional cameras' IP addresses into their respective Cam IP text field. Refer to the following table for camera IP assignment logic:

Camera Number (Order of Priority)	Camera IP Address Assignment
Camera 2	Cam IP 2
Camera 3	Cam IP 3
Camera 4	Cam IP 4
Camera 5	Cam IP 5

7. Select the **Optimize Settings for Multi-Camera** button.
8. Select the **Save Settings** button to save the configuration.

Visual Cue Intelligent Switching is now configured.

Custom Intelligent Switching Configuration

Custom Intelligent Switching utilizes a host camera (IV-CAM-I12 set to Group Framing or IV-CAM-I12D-B) and up to four other Crestron 1 Beyond cameras (IV-CAM-P12/P20 models and IV-CAM-I12/I20 models).

Camera switching in this configuration is custom programmed, and occurs depending on the desired method created. To activate Custom Intelligent Switching:

NOTE: Additional Presenter Tracking and Group Framing settings require configuration for **Intelligent Switching** to operate properly. For more information on Presenter Tracking and Group Framing settings, refer to [Tracking Settings on page 219](#).

1. Select **Tracking** on the host camera in the camera list to access the **Tracking** menu.

Tracking Button

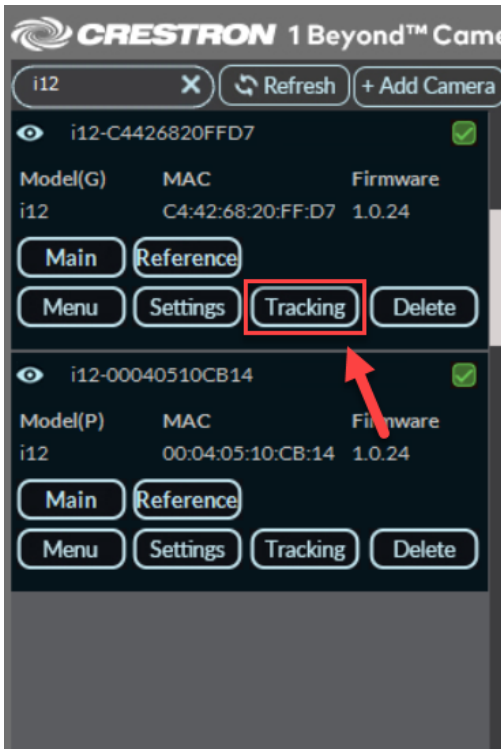

The Tracking Menu is displayed.

Tracking Menu

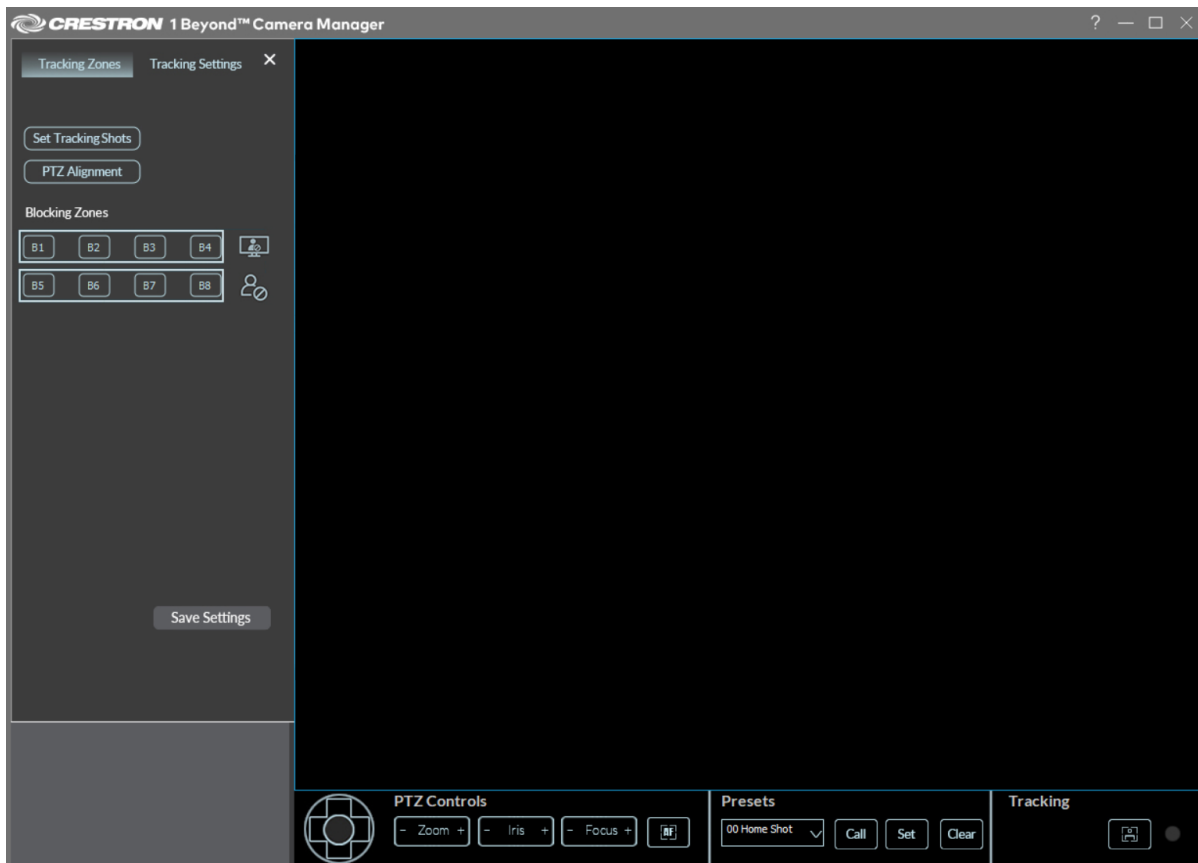

2. Select the **Tracking Settings** tab to access the **Tracking Settings**.
Select Tracking Settings



The **Tracking Settings** menu is displayed. The **Multi-Cam Tracking** settings are located at the bottom of the **Tracking Settings** menu.

Tracking Settings

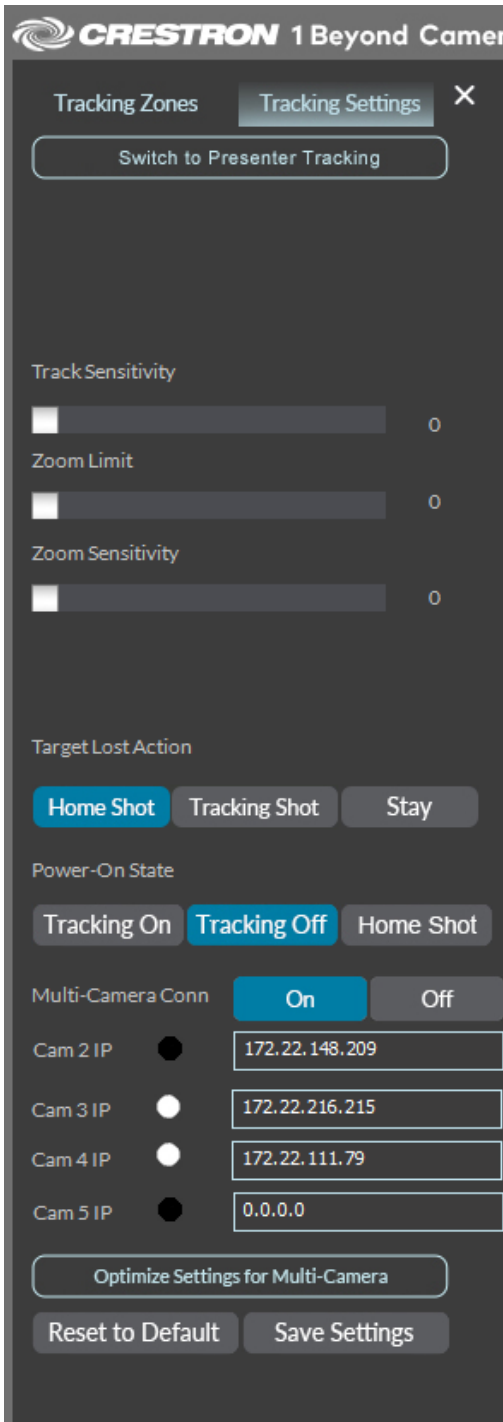

3. Enable **Multi-Cam Tracking** by selecting **On**.

Multi-Camera Tracking Settings

Multi-Camera Conn	On	Off
Cam 2 IP	●	172.22.148.209
Cam 3 IP	●	172.22.216.215
Cam 4 IP	●	172.22.111.79
Cam 5 IP	●	0.0.0.0

Optimize Settings for Multi-Camera

Reset to Default Save Settings

4. In the **Cam 2 IP** text field, enter the IP address of the Presenter Tracking camera (IV-CAM-I12 camera set to Presenter Tracking mode or an IV-CAM-I20 camera). For more information on setting an IP address for a camera, refer to [Set a Static IP Address on page 135](#).

NOTE: The light indicator next to the IP address text field displays the camera connection status. A white light indicates that the camera is connected and operational. If the light is black, the camera is either disconnected or not operational.

5. If more than two cameras are used in the Intelligent Switching configuration, enter the additional cameras' IP addresses into their respective Cam IP text field. Refer to the following table for camera IP assignment logic:

Camera Number (Order of Priority)	Camera IP Address Assignment
Camera 2	Cam IP 2
Camera 3	Cam IP 3
Camera 4	Cam IP 4
Camera 5	Cam IP 5

6. Select the **Save Settings** button to save the configuration.
7. Configure Intelligent Switching using the module located on the [IV-CAM-I12](#) or [IV-CAM-I12D-B](#) Product Page.

Custom Intelligent Switching is now configured.

Intelligent Switching Advanced Options

There are additional advanced options (Auto-Privacy, MJPEG Only mode, and so forth) that are configurable via the On-Screen Display menu (OSD). For more information about the On-Screen Display, refer to [On-Screen Display \(OSD\) on page 162](#).

Intelligent Switching Reserved Presets

There are reserved camera presets that are called through the Group Framing (IV-CAM-I12) camera that allow for custom control over camera video feeds. For more information about reserved camera presets, refer to [Intelligent Switching Presets on page 160](#).

VISCA Commands

Crestron 1 Beyond cameras can be controlled using the VISCA protocol through either a serial (RS-232 / RS-485) or TCP connection. By default, the port for TCP control is set to 5500. For serial communication, make sure the baud rate of the controller is set to 9600 bps. Below is a comprehensive list of VISCA commands that can be used to control the cameras.

NOTE: Cameras cannot use any VISCA commands if they are in Privacy Mode. Send the wake command to the camera before sending any other VISCA commands to the camera.

Call Camera Preset

To call a reserved preset, convert the camera preset value to hexadecimal. Then, call the following command:

Command	Command Packet	Comments
Call Camera Preset	8x 01 04 3F 02 yy FF	Call reserved preset, camera addr x. yy = hexadecimal value of camera preset.

For more information on reserved presets, refer to [Reserved Presets on page 160](#).

ACK / Completion Messages

Command	Command Message	Comments
ACK	z0 4y FF (y:Socket No.)	Returned when the command is accepted.
Completion	z0 5y FF (y:Socket No.)	Returned when the command has been executed.

Error Messages

Command	Command Message	Comments
Syntax Error	z0 6y 02 FF	Returned when the command format is different or when a command with illegal command parameters is accepted.
Command Buffer Full	z0 6y 03 FF	Indicates that two sockets are already being used (executing two commands) and the command could not be accepted when received.
Command Canceled	z0 6y 04 FF (y:Socket No.)	Returned when a command which is being executed in a socket specified by the cancel command is canceled. The completion message for the command is not returned.
No Socket	z0 6y 05 FF (y:Socket No.)	Returned when no command is executed in a socket specified by the cancel command, or when an invalid socket number is specified.

Command	Command Message	Comments
Command Not Executable	z0 6y 41 FF (y:Execution command Socket No. Inquiry command:0)	Returned when a command cannot be executed due to current conditions. For example, when commands controlling the focus manually are received during auto focus.

z = Device address + 8

Commands

Command Set	Command	Command Packet	Comments	
AddressSet	Broadcast	88 30 01 FF	Address setting	
IF_Clear	Broadcast	88 01 00 01 FF	I/F Clear	
Command Cancel		8x 2p FF	p: Socket No. (=1 or 2)	
CAM_Power	On	8x 01 04 00 02 FF	Power On/Off	
	Off	8x 01 04 00 03 FF		
CAM_Zoom	Stop	8x 01 04 07 00 FF	p: 0(Low)to 7 (High)	
	Tele(Standard)	8x 01 04 07 02 FF		
	Wide(Standard)	8x 01 04 07 03 FF		
	Tele(Variable)	8x 01 04 07 2p FF		
	Wide(Variable)	8x 01 04 07 3p FF		
	Direct	8x 01 04 47 0p 0q 0r 0s FF		p,q,r,s: Zoom Position
	Absolute Position	8x 01 04 47 0t 0p 01 04 0s FF		t:speed 0 - 7; p,q,r,s: Zoom Position
CAM_Focus	Stop	8x 01 04 08 00 FF	p: 0 (Low) to 7 (High)	
	Far(Standard)	8x 01 04 08 02 FF		
	Near(Standard)	8x 01 04 08 03 FF		
	Far(Variable)	8x 01 04 08 2p FF		
	Near(Variable)	8x 01 04 08 3p FF		
	Direct	8x 01 04 48 0p 0q 0r 0s FF		p,q,r,s: Focus Position
	Auto Focus	8x 01 04 38 02 FF		AF On/Off
	Manual Focus	8x 01 04 38 03 FF		
	Auto/Manual	8x 01 04 38 10 FF		
	One Push Trigger	8x 01 04 18 01 FF		One Push AF Trigger
CAM_ZoomFocus	Direct	8x 01 04 47 0p 0q 0r 0s 0t 0u 0v 0w FF	p,q,r,s: Zoom Position t,u,v,w: Focus Position	

Command Set	Command	Command Packet	Comments
CAM_WB	Auto	8x 01 04 35 00 FF	Normal Auto
	Indoor	8x 01 04 35 01 FF	Indoor Mode
	Outdoor	8x 01 04 35 02 FF	Outdoor Mode
	One Push WB	8x 01 04 35 03 FF	One Push WB Mode
	Manual	8x 01 04 35 05 FF	Manual Control Mode
	One Push Trigger	8x 01 04 10 05 FF	One Push WB Trigger
CAM_RGain	Reset	8x 01 04 03 00 FF	Manual Control of R Gain
	Up	8x 01 04 03 02 FF	
	Down	8x 01 04 03 03 FF	
	Direct	8x 01 04 43 00 00 0p 0q FF	p,q: R Gain
CAM_BGain	Reset	8x 01 04 04 00 FF	Manual Control of B Gain
	Up	8x 01 04 04 02 FF	
	Down	8x 01 04 04 03 FF	
	Direct	8x 01 04 44 00 00 0p 0q FF	p,q: B Gain
CAM_AE	Full Auto	8x 01 04 39 00 FF	Automatic Exposure mode
	Manual	8x 01 04 39 03 FF	Manual Control mode
	Shutter Priority	8x 01 04 39 0A FF	Shutter Priority Automatic Exposure mode
	Iris Priority	8x 01 04 39 0B FF	Iris Priority Automatic Exposure mode
	Bright	8x 01 04 39 0D FF	Bright Mode (Manual control)
CAM_Shutter	Reset	8x 01 04 0A 00 FF	Shutter Setting
	Up	8x 01 04 0A 02 FF	
	Down	8x 01 04 0A 03 FF	
	Direct	8x 01 04 4A 00 00 0p 0q FF	p,q: Shutter Position
CAM_Iris	Reset	8x 01 04 0B 00 FF	Iris Setting
	Up	8x 01 04 0B 02 FF	
	Down	8x 01 04 0B 03 FF	
	Direct	8x 01 04 4B 00 00 0p 0q FF	p,q: Iris Position

Command Set	Command	Command Packet	Comments
CAM_Gain	Reset	8x 01 04 0C 00 FF	Gain Setting
	Up	8x 01 04 0C 02 FF	
	Down	8x 01 04 0C 03 FF	
	Direct	8x 01 04 4C 00 00 0p 0q FF	
CAM_Bright	Reset	8x 01 04 0D 00 FF	Bright Setting
	Up	8x 01 04 0D 02 FF	
	Down	8x 01 04 0D 03 FF	
	Direct	8x 01 04 4D 00 00 0p 0q FF	
CAM_ExpComp	On	8x 01 04 3E 02 FF	Exposure Compensation On/Off
	Off	8x 01 04 3E 03 FF	
	Reset	8x 01 04 0E 00 FF	Exposure Compensation Amount Setting
	Up	8x 01 04 0E 02 FF	
	Down	8x 01 04 0E 03 FF	
	Direct	8x 01 04 4E 00 00 0p 0q FF	
CAM_Backlight	On	8x 01 04 33 02 FF	Back Light Compensation ON/OFF
	Off	8x 01 04 33 03 FF	
CAM_Memory	Reset	8x 01 04 3F 00 pp FF	pp: Memory Number (=0 to 255) Corresponds to 0 to 255 on the Remote.
	Set	8x 01 04 3F 01 pp FF	
	Recall	8x 01 04 3F 02 pp FF	
Freeze	Freeze On	8x 01 04 62 02 FF	Freeze On Immediately
	Freeze Off	8x 01 04 62 03 FF	Freeze Off Immediately
	Preset Freeze On	8x 01 04 62 22 FF	Freeze On When Running Preset
	Preset Freeze Off	8x 01 04 62 23 FF	Freeze Off When Running Preset
IR_Receive	On	8x 01 06 08 02 FF	IR receiver On/Off
	Off	8x 01 06 08 03 FF	

Command Set	Command	Command Packet	Comments
Pan-tiltDrive	Up	8x 01 06 01 VV WW 03 01 FF	VV: Pan speed 0 x01 (low speed) to 0 x18 (high speed)
	Down	8x 01 06 01 VV WW 03 02 FF	
	Left	8x 01 06 01 VV WW 01 03 FF	WW: Tilt Speed 0 x 01 (low speed) to 0 x14 (high speed)
	Right	8x 01 06 01 VV WW 02 03 FF	
	Up Left	8x 01 06 01 VV WW 01 01 FF	
	Up Right	8x 01 06 01 VV WW 02 01 FF	YYYY: pan absolute position: 1 angle=14.4;
	Down Left	8x 01 06 01 VV WW 01 02 FF	
	Down Right	8x 01 06 01 VV WW 02 02 FF	
	Stop	8x 01 06 01 VV WW 03 03 FF	
	Absolute Position	8x 01 06 02 VV WW 0Y 0Y 0Y 0Y 0Z 0Z 0Z 0Z FF	vv indicates pan speed: 1-0x18 ww indicates tilt speed: 1-0x14
	Relative Position	8x 01 06 03 VV WW 0Y 0Y 0Y 0Y 0Z 0Z 0Z 0Z FF	
	Home	8x 01 06 04 FF	
PTZ Correction	8x 01 06 05 FF	Resets the PTZ head position	
Pan-tiltLimitSet	Limit Set	8x 01 06 07 00 0W 0Y 0Y 0Y 0Y 0Z 0Z 0Z 0Z FF	W: 1 Up Right 0: Down Left YYYY: Pan Limit Position ZZZZ: Tilt Position
CAM_MountMode	Stand	8x 01 04 A4 02 FF	Inverted video and PTZ control off
	Ceiling	8x 01 04 A4 03 FF	Inverted video and PTZ control on

NOTE: IV-CAM-P12 and IV-CAM-P20 only.

Inquiry Commands

Inquiry Command	Command Packet	Inquiry Packet	Comments
CAM_PowerInq	8x 09 04 00 FF	y0 50 02 FF	On
		y0 50 03 FF	Off (Standby)
		y0 50 04 FF	Internal power circuit error
CAM_ZoomPosInq	8x 09 04 47 FF	y0 50 0p 0q 0r 0s FF	p,q,r,s: Zoom Position
CAM_FocusModelInq	8x 09 04 38 FF	y0 50 02 FF	Auto Focus
		y0 50 03 FF	Manual Focus
CAM_FocusPosInq	8x 09 04 48 FF	y0 50 0p 0q 0r 0s FF	p,q,r,s: Focus Position
CAM_WBModelInq	8x 09 04 35 FF	y0 50 00 FF	Auto
		y0 50 01 FF	In Door
		y0 50 02 FF	Out Door
		y0 50 03 FF	One Push WB
		y0 50 05 FF	Manual
CAM_RGainInq	8x 09 04 43 FF	y0 50 00 00 0p 0q FF	p,q: R Gain
CAM_BGainInq	8x 09 04 44 FF	y0 50 00 00 0p 0q FF	p,q: B Gain
CAM_AEModelInq	8x 09 04 39 FF	y0 50 00 FF	Full Auto
		y0 50 03 FF	Manual
		y0 50 0A FF	Shutter Priority
		y0 50 0B FF	Iris Priority
		y0 50 0D FF	Bright
CAM_ShutterPosInq	8x 09 04 4A FF	y0 50 00 00 0p 0q FF	p,q: Shutter Position
CAM_IrisPosInq	8x 09 04 4B FF	y0 50 00 00 0p 0q FF	p,q: Iris Position
CAM_GainPosInq	8x 09 04 4C FF	y0 50 00 00 0p 0q FF	p,q: Gain Position
CAM_BrightPosInq	8x 09 04 4D FF	y0 50 00 00 0p 0q FF	p,q: Bright Position
CAM_ExpCompModelInq	8x 09 04 3E FF	y0 50 02 FF	On
		y0 50 03 FF	Off

Inquiry Command	Command Packet	Inquiry Packet	Comments	
CAM_ExpCompPosInq	8x 09 04 4E FF	y0 50 00 00 0p 0q FF	p,q: ExpComp Position	
CAM_BacklightModelInq	8x 09 04 33 FF	y0 50 02 FF	On	
		y0 50 03 FF	Off	
CAM_MemoryInq	8x 09 04 3F FF	y0 50 0p FF	p: Memory number last operated.	
CAM_VersionInq	8x 09 00 02 FF	y0 50 00 01	m,n,p,q: Model Code	
		mn pq rs tu vw FF	r,s,t,u: ROM version	
			v,w: Socket Number	
VideoSystemInq	8x 09 06 23 FF	y0 50 00 FF	1920 x1080i/60	60 Hz system
		y0 50 01 FF	1920 x1080p/30	60 Hz system
		y0 50 02 FF	1280 x720p/60	60 Hz system
		y0 50 03 FF	1280 x720p/30	60 Hz system
		y0 50 07 FF	1920 x1080p/60	60 Hz system
		y0 50 08 FF	1920 x1080i/50	50 Hz system
		y0 50 09 FF	1920 x1080p/25	50 Hz system
		y0 50 0A FF	1280 x720p/50	50 Hz system
		y0 50 0B FF	1280 x 720p/25	50 Hz system
IR_Receive	8x 09 06 08 FF	y0 50 02 FF	On	
		y0 50 03 FF	Off	
Pan-tiltMaxSpeedI	8x 09 06 11 FF	y0 50 ww zz FF	ww = Pan Max Speed zz = Tilt Max Speed	
Pan-tiltPosInq	8x 09 06 12 FF	y0 50 0w 0w 0w 0w 0z 0z 0z 0z FF	wwww = Pan Position zzzz = Tilt Position	
Pan-tiltModelInq	8x 09 06 10 FF	y0 50 pq rs FF	p,q,r,s: Pan/Tilt Status	
CAM_TrackingInq	8x 09 08 01 FF	y0 50 02 FF	Checks if tracking is active	
		y0 50 03 FF	Checks if tracking is paused	
CAM_MountModelInq	8x 09 04 A4 FF	y0 50 02 FF	Stand	
	8x 09 04 A4 FF	y0 50 03 FF	Ceiling	

Zoom Ratio / Position (CAM_Zoom)

(CAM_Zoom Direct – p,q,r,s Zoom Position)

12x Zoom

Optical Zoom Ratio	Optical Zoom Ratio
1x	0000
2x	1982
3x	24E2
4x	2BC9
5x	3099
6x	343D
7x	3724
8x	3988
9x	3B8B
10x	3D43
11x	3EBB
12x	4000

20x Zoom

Optical Zoom Ratio	Optical Zoom Ratio
1x	0000
2x	1851
3x	22BE
4x	28F6
5x	2D45
6x	3086
7x	3320
8x	3549
9x	371E
10x	38B3
11x	3A12
12x	3B42
13x	3C47
14x	3D25
15x	3DDF
16x	3E7B
17x	3EFB
18x	3F64
19x	3FBA
20x	4000

Exposure Comp (CAM_ExpComp)

(CAM_ExpComp Direct – p,q ExpComp Position)

OE	+7	0000
OD	+6	1851
OC	+5	22BE
OB	+4	28F6
OA	+3	2D45
O9	+2	3086
O8	+1	3320
O7	0	3549
O6	-1	371E
O5	-2	38B3
O4	-3	3A12
O3	-4	3B42
O2	-5	3C47
O2	-6	3D25
O0	-7	4000

VISCA Lightbar Commands

Crestron 1 Beyond cameras feature a lightbar that can be controlled using the VISCA protocol through either a serial (RS-232 / RS-485) or TCP connection. By default, the camera's lightbar displays the following colors to reflect their status:

Lightbar Color	Camera Status	VISCA Command
Full green	Intelligent camera function ON	8x c1 0C 0C 0C 0C ff
Half green	Camera output ON	8x c1 00 0C 0C 00 ff
Full yellow	Firmware update in progress	8x c1 0F 0F 0F 0F ff
Half red	Privacy Mode ON (camera output OFF)	8x c1 01 0D 0D 01 ff

Common VISCA Lightbar Commands

Refer to the following table for common VISCA commands that can change the camera's lightbar to the desired color, brightness, and width.

Width	Color	Brightness Level	VISCA Command
None	None	None	8x c1 00 00 00 00 ff
Full	Green	Bright	8x c1 0C 0C 0C 0C ff
Full	Green	Medium	8x c1 08 08 08 08 ff
Full	Green	Dim	8x c1 04 04 04 04 ff
Full	Yellow	Bright	8x c1 0F 0F 0F 0F ff
Full	Yellow	Medium	8x c1 0B 0B 0B 0B ff
Full	Yellow	Dim	8x c1 07 07 07 07 ff
Full	Red	Bright	8x c1 0D 0D 0D 0D ff
Full	Red	Medium	8x c1 09 09 09 09 ff
Full	Red	Dim	8x c1 05 05 05 05 ff
Half	Green	Bright	8x c1 00 0C 0C 00 ff
Half	Green	Medium	8x c1 00 08 08 00 ff
Half	Green	Dim	8x c1 00 04 04 00 ff
Half	Yellow	Bright	8x c1 03 0F 0F 03 ff
Half	Yellow	Medium	8x c1 03 0B 0B 03 ff
Half	Yellow	Dim	8x c1 03 07 07 03 ff
Half	Red	Bright	8x c1 01 0D 0D 01 ff
Half	Red	Medium	8x c1 01 09 09 01 ff
Half	Red	Dim	8x c1 01 05 05 01 ff

Customize the Lightbar

The camera's lightbar can be customized by using a VISCA command to display color and brightness on desired light segments. Refer to the following sections for more information on camera lightbar customization.

Available Lightbar Segments

Lightbar segments are divided into four groups that each can be customized by VISCA commands. Refer to the following information for details regarding the lights available per lightbar segment:

IV-CAM-P12 and IV-CAM-P20 series cameras: The lightbar contains four lightbar segments with 4 lights each, totaling 16 lights.

IV-CAM-I12-B and IV-CAM-I20 series cameras: The lightbar contains two outer segments with 4 lights each and two inner segments with 3 lights each, totaling 14 lights.

Create a Custom VISCA Lightbar Command

To determine the desired brightness and color codes within the VISCA command, the binary values must be translated to hexadecimal code. Refer to the following procedure to create a custom lightbar VISCA command:

NOTE: This is an advanced procedure that requires the knowledge of binary values, hexadecimal code, and VISCA commands.

1. Use the following tables to determine the binary values for the hexadecimal code. The binary value string created should have 16 digits separated into four 4 digit segments.

Brightness Codes

Brightness levels	Binary Values
OFF	00
Dim	01
Medium	10
Bright	11

Color Codes

Color Options	Binary Values
Green	00
Red	01
Yellow	11

2. Convert the binary values into hexadecimal code. Each 4 digit segment of the binary value string must be individually converted into hexadecimal values. Each binary value string should result in two hexadecimal characters.
3. Place each separate two character hexadecimal value in sequence with a single space between them.

- Place the hexadecimal values into the lightbar VISCA command format. The VISCA command structure is as follows (where asterisks **** represent the brightness and color codes in the command):

8x c1 ** ** ** ** ff

- The VISCA command can be sent via a serial (RS-232 / RS-485) or TCP connection to change the camera's lightbar indicator.

The camera's lightbar has now been changed to display the desired brightness and color.

VISCA Lightbar Command Example

Refer to the following table for the binary values, hexadecimal code, and the VISCA command for bright green on the two inner segments (hereafter referred to as "half-width") lightbar.

Bright Green Half-Width Lightbar Example

Binary Value	Hexadecimal Code	VISCA Command
0000 1100 1100 0000	00 0C 0C 00	8x c1 00 0C 0C 00 ff

The VISCA command for the lightbar to display half-width bright green is determined by the following procedure:

- The binary values for the bright green half-width lightbar are 0000 1100 1100 0000. Refer to the following explanation on how the binary values were determined:
 - The 0000 binary value correlates with 00 (OFF) and 00 (Green).
 - The 1100 binary value correlates with 11 (Bright) and 00 (Green).
- The bright green half-width lightbar binary values (0000 1100 1100 0000) are converted into hexadecimal code. Refer to the following explanation on how the hexadecimal code was determined:
 - 0000 converted into hexadecimal is 00.
 - 1100 converted into hexadecimal is 0C.

The result for the bright green half-width lightbar hexadecimal code is 00 0C 0C 00.

- The hexadecimal code is placed into the VISCA command format (**8x c1 ** ** ** ** ff**) to give the final result of 8x c1 00 0C 0C 00 ff.
- The VISCA command for the bright green half-width lightbar (8x c1 00 0C 0C 00 ff) is sent via a serial (RS-232 / RS-485) or TCP connection to the camera.

The camera's lightbar now displays as bright green on the two inner segments.

VISCA Intelligent Switching Commands

Intelligent Switching with Crestron 1 Beyond Cameras is controlled using the VISCA protocol through a TCP connection. For more information about Intelligent Switching and how it is configured, refer to [Intelligent Switching on page 232](#).

Below is a comprehensive list of VISCA commands that can be used to control the cameras.

Placeholder Text Key

Refer to the following table for information about what certain placeholder letters indicate in the Intelligent Switching VISCA commands:

Placeholder Letter	Definition
X	Camera Address
Z	Camera ID (2, 3, 4, 5)
W	IP Address (each W represents one digit of the IP address in hexadecimal)

Command	Command Packet	Ack Response	Comments
Get Output	8x C2 09 08 FF	Intelligent Switching On: <ul style="list-style-type: none"> • Camera 1: Y0 50 01 01 FF • Camera 2: Y0 50 01 02 FF • Camera 3: Y0 50 01 03 FF • Camera 4: Y0 50 01 04 FF • Camera 5: Y0 50 01 05 FF Intelligent Switching Off: <ul style="list-style-type: none"> • Camera 1: Y0 50 00 01 FF • Camera 2: Y0 50 00 02 FF • Camera 3: Y0 50 00 03 FF • Camera 4: Y0 50 00 04 FF • Camera 5: Y0 50 00 05 FF 	Returns the camera output
Check Connection Status (2/3/4/5)	8x c2 09 0d 0Z ff	Disconnect: Y0 50 00 00 FF Connect: Y0 50 00 01 FF	Returns the connection status of the camera and Intelligent Switching

Perform a Factory Restore

If the IV-CAM Series camera must be restored to its factory default settings, press and hold the recessed **RESET** button on the rear of the camera for 10 seconds. After holding the **RESET** button for 10 seconds, the camera restarts.

CAUTION: Performing a factory restore returns all settings to their default values and removes the camera's static IP address, camera control protocol connections, and Automate VX connections. To configure a IV-CAM Series camera after performing a factory restore, refer to [Initial Setup on page 112](#).

Once the camera has finished powering up after the restart, the camera is now restored to the factory defaults.

Resources

The following resources are provided for the IV-CAM Series.

NOTE: You may need to provide your Crestron.com web account credentials when prompted to access some of the following resources.

Crestron Support and Training

- [Crestron True Blue Support](#)
- [Crestron Resource Library](#)
- [Crestron Online Help \(OLH\)](#)
- [Crestron Training Institute \(CTI\) Portal](#)

Product Certificates

To search for product certificates, refer to support.crestron.com/app/certificates.

