

Tabletop Cable Organizer

The TT-CMK provides convenient tabletop cable management. The cable organizer routes network, audio, and video connections to a user's laptop for Bring Your Own Device (BYOD) presentation from a room box or room controller mounted under the table.



In the Box

- 1 Cable organizer housing, Plastic, Black (2056826)
- 1 Cable organizer plate, Plastic, Black (2056825)
- 2 Locking nut, Plastic, Black (2056824)
- 2 Screw, 4-40 x 3/8 in., Pan Head, Phillips, Black (2007170)



Install the Cable Organizer

To install the cable organizer:

1. Select a mounting surface with a thickness of 1 in. (25 mm) to 1.5 in. (38 mm).
2. Use a hole saw to cut a 2.5 in. (64 mm) wide mounting hole in the mounting surface.
3. Insert the cable organizer housing into the mounting hole.

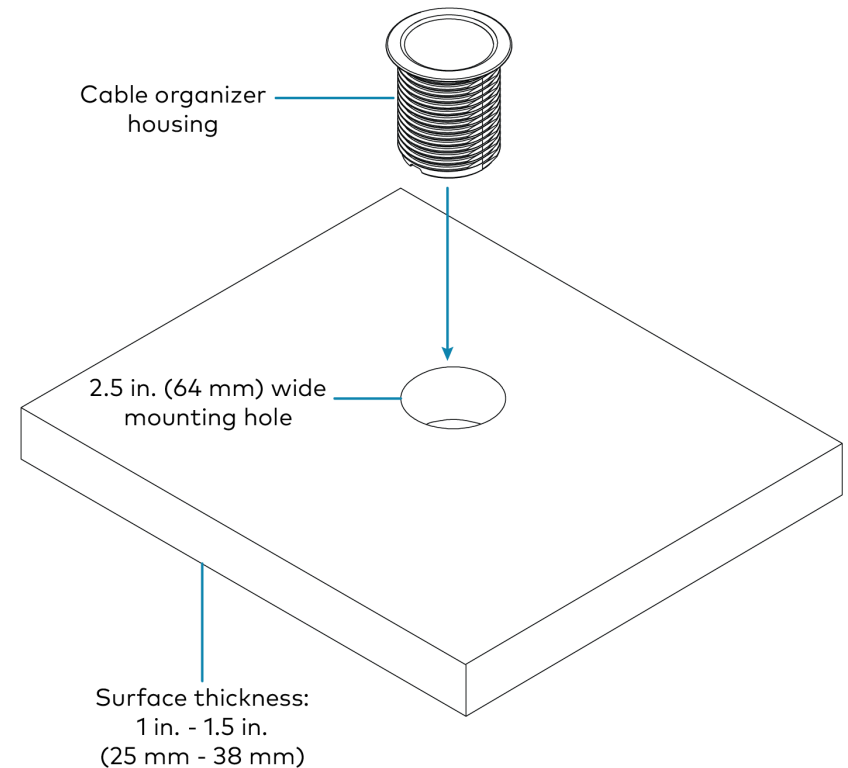

Tabletop Cable Organizer

- Secure the cable organizer housing to the mounting surface using the included locking nuts. Ensure the TOP label on the locking nuts is face up.

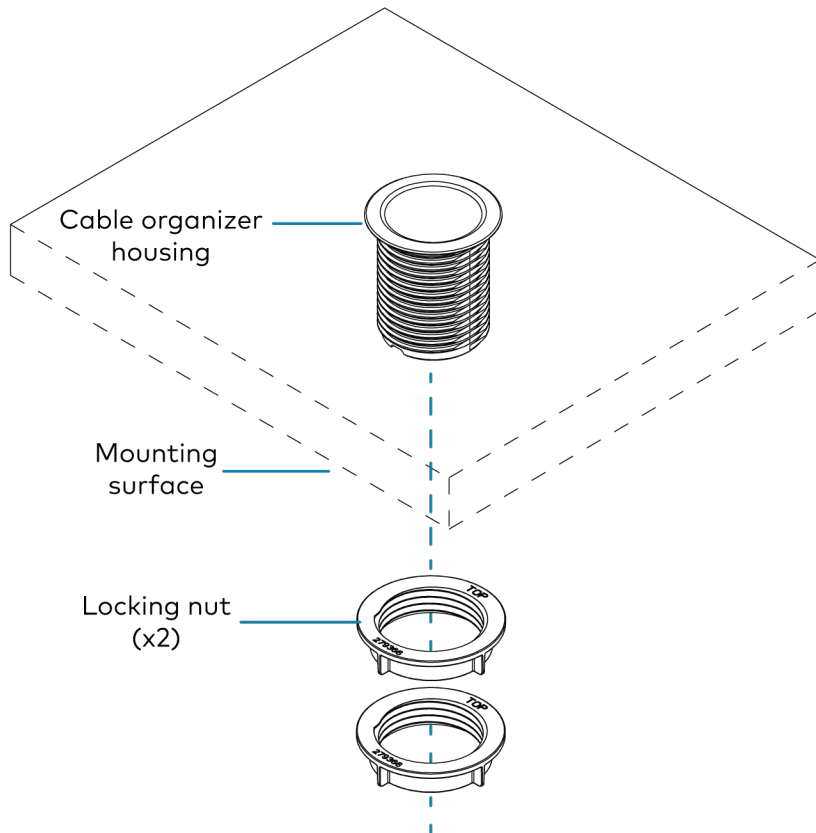

- Pass cables through the bottom of the cable organizer housing to the tabletop.
- Route the cables through the routing holes on the cable organizer plate.

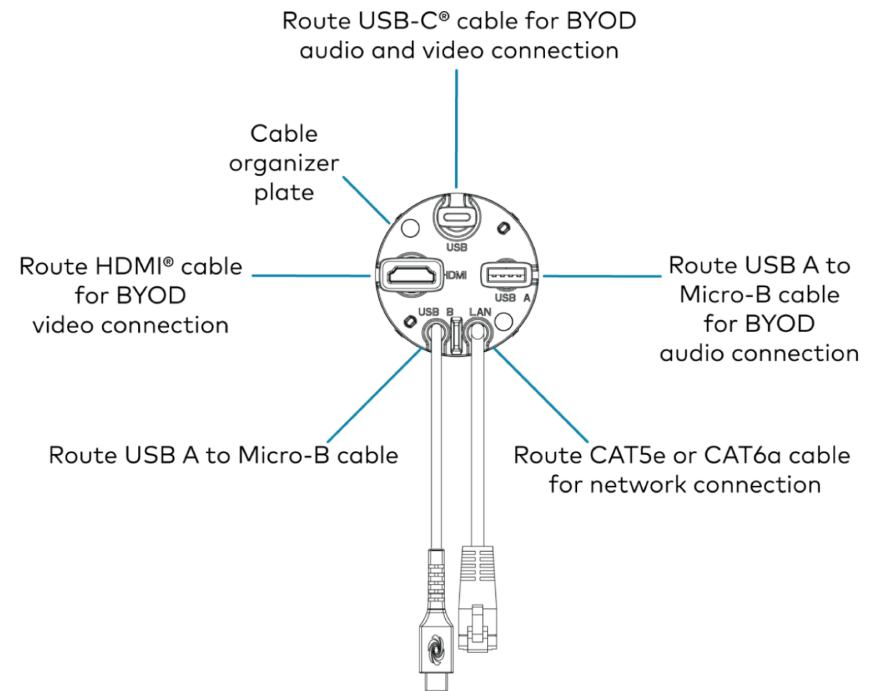

Tabletop Cable Organizer

7. Attach the cable organizer plate to the cable organizer housing with the included screws.

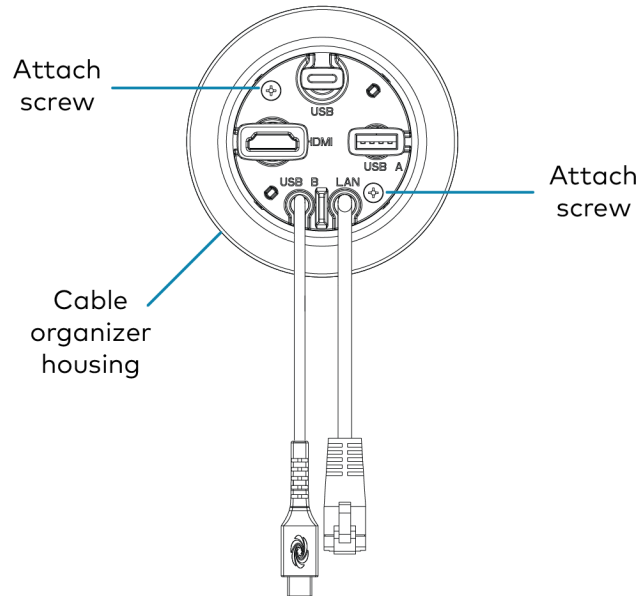

8. Above the mounting surface, pull all of the cables out to the needed length. Ensure there is at least 2 in. (51 mm) of cable slack beneath the mounting surface, and attach a cable tie (not included) to each cable. Trim the cable ties as needed and push the cables back to the cable organizer plate.

Scan the QR code to visit the product page.

TT-CMK



www.crestron.com/model/6514187

Tabletop Cable Organizer

Additional Information

Original Instructions

The U.S. English version of this document is the original instructions. All other languages are a translation of the original instructions.

Crestron product development software is licensed to Crestron dealers and Crestron Service Providers (CSPs) under a limited nonexclusive, nontransferable Software Development Tools License Agreement. Crestron product operating system software is licensed to Crestron dealers, CSPs, and end-users under a separate End-User License Agreement. Both of these Agreements can be found on the Crestron website at www.crestron.com/legal/software_license_agreement.

The product warranty can be found at www.crestron.com/warranty.

The specific patents that cover Crestron products are listed at www.crestron.com/legal/patents.

Certain Crestron products contain open source software. For specific information, visit www.crestron.com/opensource.

Crestron and the Crestron logo are either trademarks or registered trademarks of Crestron Electronics, Inc. in the United States and/or other countries. HDMI is either a trademark or registered trademark of HDMI Licensing LLC in the United States and/or other countries. USB-C is either a trademark or registered trademark of USB Implementers Forum, Inc. in the United States and/or other countries. Other trademarks, registered trademarks, and trade names may be used in this document to refer to either the entities claiming the marks and names or their products. Crestron disclaims any proprietary interest in the marks and names of others. Crestron is not responsible for errors in typography or photography.

©2025 Crestron Electronics, Inc.

Doc. 9527A

04/15/25