



View this document in HTML
<https://www.crestron.com/docs/9560>



Product Manual

KP-DEMO-BOX-CM2

Demo Box for Cameo® 2 Devices

Have feedback on this document? Contact docfeedback@crestron.com.

The original language version of this document is U.S. English.
All other languages are a translation of the original document.

Crestron product development software is licensed to Crestron dealers and Crestron Service Providers (CSPs) under a limited nonexclusive, nontransferable Software Development Tools License Agreement. Crestron product operating system software is licensed to Crestron dealers, CSPs, and end-users under a separate End-User License Agreement. Both of these Agreements can be found on the Crestron website at www.crestron.com/legal/software_license_agreement.

The product warranty can be found at www.crestron.com/warranty.

The specific patents that cover Crestron products are listed online at www.crestron.com/legal/patents.

Certain Crestron products contain open source software. For specific information, please visit www.crestron.com/opensource.

Crestron, the Crestron logo, and Cameo are either trademarks or registered trademarks of Crestron Electronics, Inc. in the United States and/or other countries. Intertek is either a trademark or registered trademark of Intertek Group in the United States and/or other countries. Other trademarks, registered trademarks, and trade names may be used in this document to refer to either the entities claiming the marks and names or their products. Crestron disclaims any proprietary interest in the marks and names of others. Crestron is not responsible for errors in typography or photography.

©2026 Crestron Electronics, Inc.

Contents

- KP-DEMO-BOX-CM2** 1
- Overview** 2
 - Features 2
 - Specifications 3
 - Dimension Drawings 4
- Installation** 5
 - In the Box 6
 - Install the Batteries 7
 - Prepare the Keypad 8
 - Mounting a CM2-KPCN 8
 - Mounting a CM2-KPFCN 11
- Operation** 12
 - Demo Mode 12
- Resources** 13
 - Crestron Support and Training 13
 - Programmer and Developer Resources 13
 - Product Certificates 13
 - Related Documentation 13

KP-DEMO-BOX-CM2

The KP-DEMO-BOX-CM2 provides a stylish and convenient way to showcase Cameo® 2 keypad options and capabilities.

Overview

The KP-DEMO-BOX-CM2 provides a stylish and convenient way to showcase Cameo® 2 keypad options and capabilities. The box accommodates one CM2-KPCN or CM2-KPFCN that can be outfitted with a variety of faceplates and buttons.



Shown with CM2-KPCN (not included)

Features

- Attractive box showcases a Cameo 2 keypad at a perfect angle
- Powers keypad for full-featured demonstrations
- Accommodates one [CM2-KPCN](#) (not included) or [CM2-KPFCN](#) (not included)

Demo Mode

Preprogrammed demo modes highlight the functionality of the Cameo 2 keypad. Demonstrate RGB color cycling, tunable white, and button feedback for system statuses.

Simple Installation

The CM2-KPCN is screwed into place, while the CM2-KPFCN is held in place with its integrated spring clips. Easily swap out one keypad for another to showcase different button styles or color finishes. Two 9V batteries (not included) power the connected keypad.

Carrying Case

The [KP-DEMO-CASE](#) (sold separately) holds up to six [CM2-KPCN](#), [CM2-KPFCN](#), or [HZ2-KPCN](#) units. Prepare multiple keypads with a variety of finishes and button styles to present options to clients.

Specifications

Power Requirements

Power (2) 9V batteries (not included)

Dimensions

Height 3.07 in. (78 mm)

Width 4.56 in. (116 mm)

Depth 6.22 in. (158 mm)

Dimension Drawings

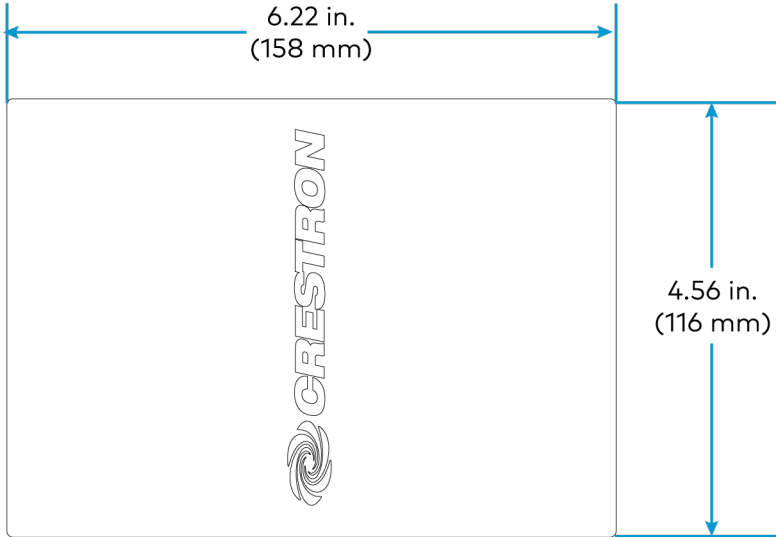
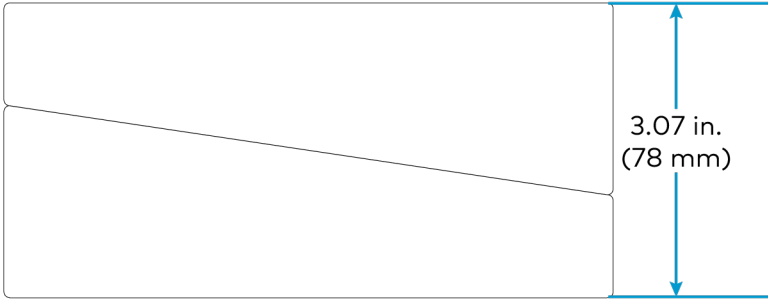

Installation

This section provides the following information:

- [In the Box](#)
- [Install the Batteries](#)
- [Prepare the Keypad](#)

In the Box

Qty.	Description
1	KP-DEMO-BOX-CM2
Additional Items	
1	Contacts (2063647)
1	Support Block (2065011) with Long Contacts (2065010)

Install the Batteries

Follow the instructions below to install batteries in the KP-DEMO-BOX-CM2. Two 9V batteries are required (not included).

1. Open the lid of the KP-DEMO-BOX-CM2.
2. Remove the four Philips screws in the middle of the keypad mount.

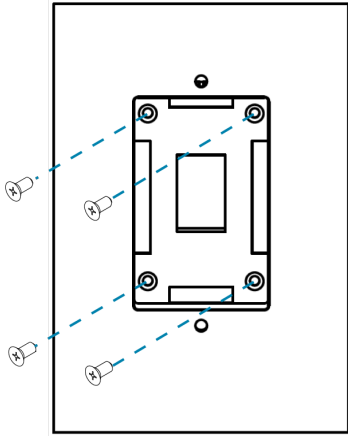

3. Remove the keypad mount to access the battery holder.
4. Gently pull on the retaining clips and insert a 9V battery into each side of the holder. Note the polarity + and - indicators.

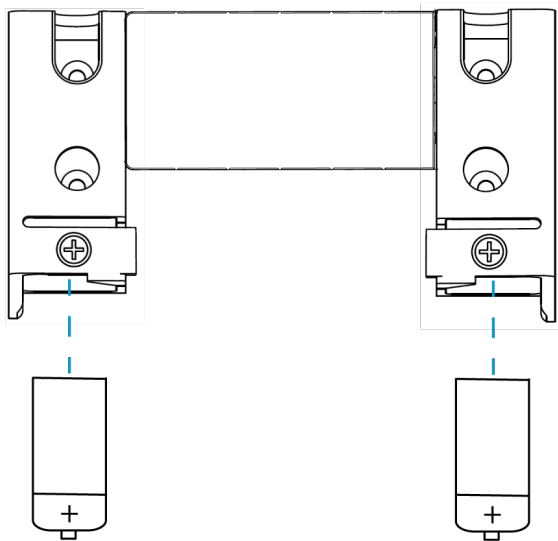

5. Snap the battery connectors onto the battery terminals.
6. Screw the keypad mount back into the box with the four Philips screws. Do not overtighten the screws.

The KP-DEMO-BOX-CM2 is now ready for mounting a CM2-KPCN or CM2-KPFCN.

Prepare the Keypad

Follow the instructions below to prepare the keypad (sold separately) for mounting in the KP-DEMO-BOX-CM2. This step requires the included metal contacts.

Mounting a CM2-KPCN

The CM2-KPCN is screwed into place. Follow the instructions below.

1. Connect the included support block with contacts to a 4-pin connector (included with the CM2-KPCN).

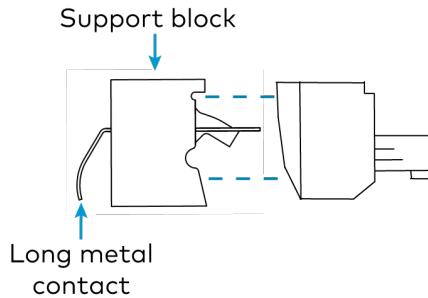

2. Screw closed all the terminals on the 4-pin connector.
3. Connect the combined support block and 4-pin connector to the middle **NET** port of the CM2-KPCN.

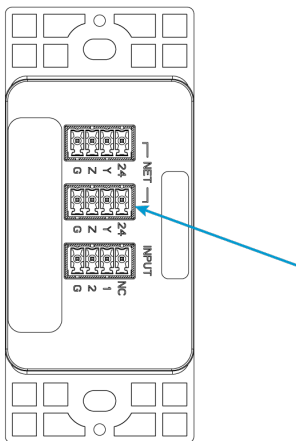

- Loosely secure the CM2-KPCN to the keypad mount using two #06-32 x 1 in. combo head mounting screws included with the CM2-KPCN. The metal contacts will line up with conductive pads in the KP-DEMO-BOX-CM2, powering the CM2-KPCN.

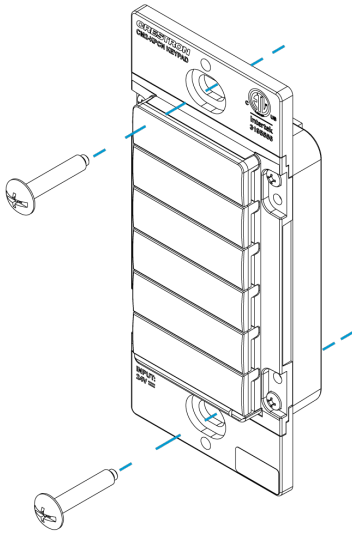

- Attach the rear of the faceplate to the CM2-KPCN using the #06-32 x 1/4 in. flat head Philips mounting screws (2007211) included with the Cameo 2 faceplate. For details, refer to the [Cameo 2 Product Manual](#).

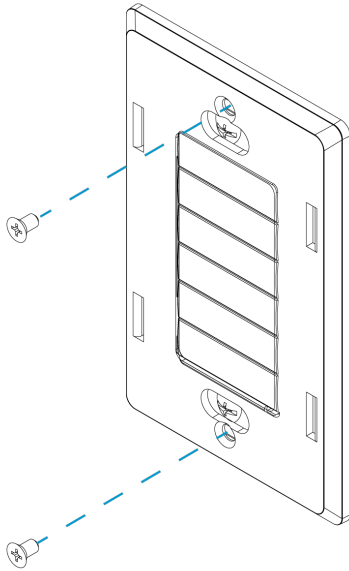

- Fully tighten the two #06-32 x 1 in. combo head mounting screws to secure the CM2-KPCN to the keypad mount.

CAUTION: Do not overtighten the screws when attaching the CM2-KPCN to the keypad mount. Damage to the unit and undesired functionality may occur.

7. Snap the faceplate onto the device.

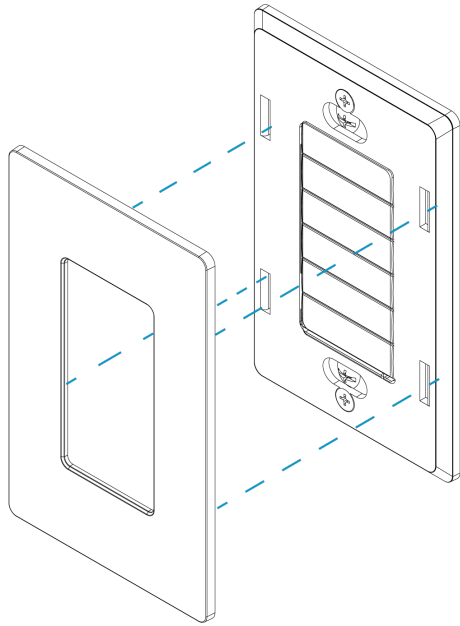

The KP-DEMO-BOX-CM2 is now ready for operation.

Mounting a CM2-KPFCN

The CM2-KPFCN is held in place with its integrated spring clips. Follow the instructions below.

1. Insert the flat ends of the short metal contacts into the **G** and **24** terminals of the 4-pin connector (included with the CM2-KPFCN). The curved portion of the contacts will protrude from the 4-pin connector.

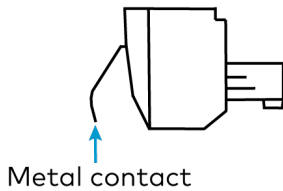
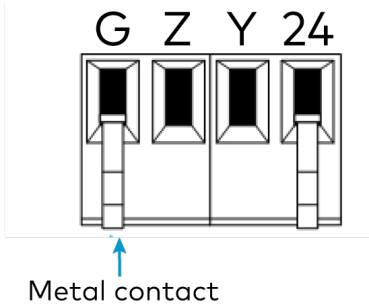

2. Insert the 4-pin connector into the middle **NET** port.

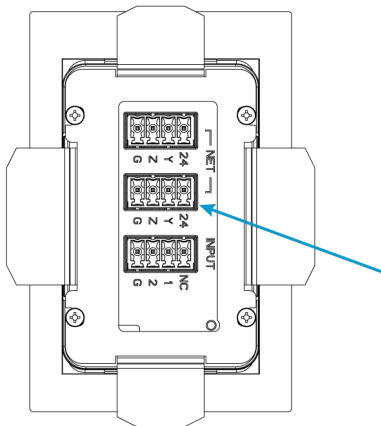

3. Insert the CM2-KPFCN into the keypad mount of the KP-DEMO-BOX-CM2. The metal contacts will line up with conductive pads in the KP-DEMO-BOX-CM2, powering the CM2-KPFCN. The CM2-KPCN remains held in place with its integrated spring clips.

The KP-DEMO-BOX-CM2 is now ready for operation.

Operation

Open the lid of the KP-DEMO-BOX-CM2 to provide power to the keypad. Closing the lid removes power.

Demo Mode

When using the KP-DEMO-BOX-CM2, utilize the keypad's demo mode to showcase backlight and button indicator functionality.

For details, refer to [Demo Mode](#) in the [Cameo 2 product manual](#).

Resources

The following resources are provided for the KP-DEMO-BOX-CM2.

NOTE: You may need to provide your Crestron.com web account credentials when prompted to access some of the following resources.

Crestron Support and Training

- [Crestron True Blue Support](#)
- [Crestron Resource Library](#)
- [Crestron Online Help \(OLH\)](#)
- [Crestron Technical Institute \(CTI\) Portal](#)

Programmer and Developer Resources

- help.crestron.com: Provides help files for Crestron programming tools such as SIMPL, SIMPL#, and Crestron Toolbox™ software
- developer.crestron.com: Provides developer documentation for Crestron APIs, SDKs, and other development tools

Product Certificates

To search for product certificates, refer to the [Product Certificates](#) section of the Crestron Resource Library.

Related Documentation

- [Crestron Technical Documentation](#)

