



View this document in HTML  
[crestron.com/docs/8622](http://crestron.com/docs/8622)



# HZ-THSTAT

## Horizon<sup>®</sup> Wireless Thermostat

### Product Manual

Have feedback on this document? Contact [docfeedback@crestron.com](mailto:docfeedback@crestron.com).

The original language version of this document is U.S. English.  
All other languages are a translation of the original document.

**Regulatory Model:** M201911001

Crestron product development software is licensed to Crestron dealers and Crestron Service Providers (CSPs) under a limited nonexclusive, nontransferable Software Development Tools License Agreement. Crestron product operating system software is licensed to Crestron dealers, CSPs, and end-users under a separate End-User License Agreement. Both of these Agreements can be found on the Crestron website at [www.crestron.com/legal/software\\_license\\_agreement](http://www.crestron.com/legal/software_license_agreement).

The product warranty can be found at [www.crestron.com/warranty](http://www.crestron.com/warranty).

The specific patents that cover Crestron products are listed online at [www.crestron.com/legal/patents](http://www.crestron.com/legal/patents).

Certain Crestron products contain open source software. For specific information, please visit [www.crestron.com/opensource](http://www.crestron.com/opensource).

Crestron, the Crestron logo, Crestron Home, Crestron Toolbox, and Horizon are either trademarks or registered trademarks of Crestron Electronics, Inc. in the United States and/or other countries. Wi-Fi is either a trademark or registered trademark of Wi-Fi Alliance in the United States and/or other countries. Other trademarks, registered trademarks, and trade names may be used in this document to refer to either the entities claiming the marks and names or their products. Crestron disclaims any proprietary interest in the marks and names of others. Crestron is not responsible for errors in typography or photography.

©2026 Crestron Electronics, Inc.

# Contents

<b>Overview</b> .....	<b>8</b>
Features .....	9
Supported Systems .....	10
<b>Specifications</b> .....	<b>11</b>
Product Specifications .....	11
Dimensions .....	15
<b>Installation</b> .....	<b>16</b>
In the Box .....	17
Equipment Required .....	18
New Electrical Box or Low Voltage Mounting Bracket .....	18
Existing Electrical Box or Low Voltage Mounting Bracket .....	18
Drywall .....	18
Determine the Mounting Location .....	19
Mounting .....	20
Mount to an Electrical Box or Low Voltage Mounting Bracket .....	20
Mount to Drywall .....	22
System Connections .....	24
R CONNECTIONS Switch .....	27
Thermistor Curve .....	28
Wiring Diagrams .....	29
Single Stage Heat-Only System without Common Wire .....	31
Single Stage Heat/Cool System without Common Wire .....	32
Single Stage Heat/Cool System .....	33
Single Stage Heat Pump with Aux Heat .....	34
2 Stage Heat Pump with 2 Stage Aux Heat .....	35
Dual Stage Heat/Cool System with Separate References and Humidification .....	36
Wiring a Local Power Source .....	37
Radiant Floor Only (Floor Warming and/or Space Heating) .....	38
2 Stage Heat (Stage 1 Radiant Floor)/1 Stage Cool or 1 Stage Heat/1 Stage cool with Floor Warming .....	39
2 Stage Heat (Stage 1 Radiant Floor)/1 Stage Cool Heat Pump with 1 Stage Aux Heat or 1 Stage Heat/1 Stage Cool Heat Pump with 1 Stage Aux Heat and Floor Warming .....	40
3 Stage Heat (Stage 1 Radiant Floor)/2 Stage Cool Heat Pump with 1 Stage Aux Heat or 2 Stage Heat/2 Stage Cool Heat Pump with 1 Stage Aux Heat and Floor Warming .....	41
2-Pipe FCU with 1 or 2 Stage Heat/Cool, with optional Radiant Floor Stage, optional Floor Warming, and optional Aux Heat Stage .....	42
2-Pipe FCU with 1 or 2 Stage Heat, with optional Radiant Floor Stage, optional Floor Warming, and optional Aux Heat Stage .....	43
2-Pipe FCU with 1 or 2 Stage Cool, with optional Radiant Floor Stage, optional Floor Warming, and optional Aux Heat Stage .....	44

4-Pipe FCU 1 Stage Heat/Cool, with optional Radiant Floor Stage, optional Floor Warming, and optional Aux Heat Stage .....	45
<b>Configuration .....</b>	<b>46</b>
Remote Thermostat Configuration .....	47
Crestron Toolbox Software Configuration .....	48
Web-Based UI Configuration .....	48
Local Thermostat Configuration .....	49
Heat/Cool, 1 or 2 Stages, Forced Air or Radiant .....	52
System Type .....	52
System Performance .....	53
User Controls .....	54
Sensor Setup .....	56
Humidistat Setup .....	57
Heat Pump, 1 or 2 Stages, Aux Heat or Dual Fuel .....	59
System Type .....	59
System Performance .....	60
User Controls .....	62
Sensor Setup .....	64
Humidistat Setup .....	65
Radiant Floor Only (Floor Warming) .....	67
Radiant Floor .....	67
System Type .....	68
User Controls .....	69
Sensor Setup .....	70
Humidistat Setup .....	71
Radiant Floor Only (Space Heating) .....	73
Radiant Floor .....	73
System Type .....	74
User Controls .....	75
Sensor Setup .....	76
Humidistat Setup .....	77
Radiant Floor Only (Floor Warming/Space Heating) .....	79
Radiant Floor .....	79
System Type .....	80
User Controls .....	81
Sensor Setup .....	82
Humidistat Setup .....	83
2 Stage Heat (Stage 1 Radiant Floor)/1 Stage Cool .....	85
Radiant Floor .....	85
System Type .....	86
System Performance .....	87
User Controls .....	88
Sensor Setup .....	90
Humidistat Setup .....	93
2 Stage Heat (Stage 1 Radiant Floor)/1 Stage Cool Heat Pump with 1 Stage Aux Heat .....	95

Radiant Floor .....	95
System Type .....	96
System Performance .....	97
User Controls .....	99
Sensor Setup .....	101
Humidistat Setup .....	104
2 Stage Heat (Stage 1 Radiant Floor Warming/Space Heating)/1 Stage Cool .....	106
Radiant Floor .....	106
System Type .....	107
System Performance .....	108
User Controls .....	109
Sensor Setup .....	111
Humidistat Setup .....	114
2 Stage Heat (Stage 1 Radiant Floor Warming/Space Heating)/1 Stage Cool Heat Pump with 1 Stage Aux Heat .....	116
Radiant Floor .....	116
System Type .....	117
System Performance .....	118
User Controls .....	120
Sensor Setup .....	122
Humidistat Setup .....	125
2-Pipe FCU with 1 or 2 Stage Heat/Cool, with optional Radiant Floor Stage, optional Floor Warming, and optional Aux Heat Stage .....	127
System Type .....	128
System Performance .....	129
Radiant Floor .....	130
User Controls .....	131
Humidistat Setup .....	132
Sensor Setup .....	134
2-Pipe FCU with 1 or 2 Stage Heat, with optional Radiant Floor Stage, optional Floor Warming, and optional Aux Heat Stage .....	136
System Type .....	137
System Performance .....	138
Radiant Floor .....	139
User Controls .....	140
Humidistat Setup .....	140
Sensor Setup .....	142
2-Pipe FCU with 1 or 2 Stage Cool, with optional Radiant Floor Stage, optional Floor Warming, and optional Aux Heat Stage .....	144
System Type .....	145
System Performance .....	146
Radiant Floor .....	147
User Controls .....	148
Humidistat Setup .....	149
Sensor Setup .....	151

4-Pipe FCU 1 Stage Heat/Cool, with optional Radiant Floor Stage, optional Floor Warming, and optional Aux Heat Stage .....	155
System Type .....	156
System Performance .....	157
Radiant Floor .....	158
User Controls .....	159
Humidistat Setup .....	160
Sensor Setup .....	162
<b>Operation .....</b>	<b>164</b>
Overview .....	164
Lightbar and Up and Down Buttons .....	168
Weather .....	169
Side Menu .....	169
System Modes .....	170
Fan Modes .....	171
Humidity Control .....	172
Radiant Floor Control .....	172
Schedule Control .....	172
Brightness .....	173
User Settings .....	174
Display .....	175
Wireless Network .....	177
Installer Settings .....	179
Product Manual .....	180
System Configuration .....	181
End User Access .....	181
Display .....	181
Wireless Network .....	182
Location .....	183
Diagnostics .....	184
About .....	185
Reboot .....	185
Restore Device .....	185
<b>Glossary .....</b>	<b>186</b>
System Type Definitions .....	186
Radiant Floor Heating Definitions .....	187



# Overview

The Crestron® [HZ-THSTAT](#) is a versatile, wall-mounted heating and cooling thermostat with integrated humidistat capable of controlling two stage heat/cool systems, two stage heat pump systems with two auxiliary heat stages, 2-pipe and 4-pipe FCU systems, floor warming systems, and humidity systems. A Wi-Fi® thermostat, the HZ-THSTAT delivers enhanced functionality when combined with a complete Crestron automation system.

The 3.5 in. LCD touch screen display is used to configure the system type, radiant floor, system performance, sensor setup, and thermostat control settings.

Integrated proximity and ambient light sensors ensure the thermostat display looks perfect in any room lighting condition. The RGB backlit status light bar indicates HVAC calls. The thermostat behavior can be customized separately for day and night operating modes.

Using Crestron Toolbox™ software, the Thermostat Configuration Tool can be used to create a thermostat configuration, retrieve logs, and test relays. It can be used to load the configuration onto one or more thermostats at the same time. If a person is onsite, they can accept the transfer of a new thermostat configuration that is initiated remotely.

When the HZ-THSTAT is paired with the [HZA-CONV-THSTAT-2WIRE](#) Common Wire Adapter accessory (sold separately), the thermostat can be used in installations without a common wire. The HZ-THSTAT has local temperature and humidity sensors and accommodates up to four remote temperature sensors ([CHV-RTS](#), [CHV-RSS](#), [CHVI-RTS-1G-N-W](#), and [CHVI-RTS-1G-SM-W](#), sold separately) and up to two remote temperature/humidity sensors ([CHV-RTHS](#), sold separately) for optimized performance and flexibility. The HZ-THSTAT is also compatible with 10k thermistors.

This section provides the following information:

- [Features](#)
- [Supported Systems](#)

# Features

Key features include:

- Compatible with conventional 2H/2C systems, heat pump 4H/2C systems with auxiliary heat, 2-Pipe FCU 2H/2C, 4-Pipe FCU H/C, and systems with radiant flooring and humidity control
- 3.5 in. touch screen LCD display with RGB backlit capacitive buttons
- Slim design extends only 0.57 in. (14 mm) from the wall
- Control system integration via a Wi-Fi® wireless network
- Reports the current outdoor temperature and weather conditions as well as the week's forecast
- Utilizes built-in temperature and humidity sensors
- Supports up to four remote temperature sensors and up to two remote temperature/humidity sensors
- Light bar with RGB backlight provides status and indicates mode and call
- Integrated proximity and ambient light sensors ensure the thermostat looks perfect in any room lighting condition
- Supports retrofit applications with no common wire using the [HZA-CONV-THSTAT-2WIRE](#) accessory (sold separately) and as few as two wires
- Mounts to a standard US-style, 1-gang new or old work electrical box, low voltage mounting bracket, or directly to the wall
- Fan Circulation modes ensure an even temperature throughout a house
- Resettable fan run timers in the device symbol can provide filter replacement and maintenance reminders
- Hidden USB port can be used to power and preconfigure the thermostat
- Remotely initiate the deployment of one or more thermostats to support on-site personnel
- Thermostat display matches the Crestron Home® OS interface for a familiar experience
- Available in white, black, and almond

# Supported Systems

The HZ-THSTAT can control the following heating and cooling systems with or without Humidity control:

- 1 or 2-stage heat
- 1 or 2-stage cool
- 1 or 2-stage heat, 1 or 2-stage cool
- 1 or 2-stage heat pump with 1 or 2 stage auxiliary heat
- 1 or 2-stage dual fuel heat pump with 1 or 2 stage auxiliary heat
- Radiant floor only (floor warming and or space heating)
- 1 or 2 stage heat (stage 1 radiant floor with or without floor warming), 1 or 2 stage cool
- 1, 2, or 3 stage heat (stage 1 radiant floor with or without floor warming), 1 or 2 stage cool heat pump with 1 stage aux heat
- 1, 2, or 3 stage heat (stage 1 radiant floor with or without floor warming), 1 or 2 stage cool dual fuel heat pump with 1 stage aux heat
- 2-Pipe FCU with 1 or 2 Stage Heat/Cool, with Radiant Floor Stage and Floor Warming, and Aux Heat Stage
- 2-Pipe FCU with 1 or 2 Stage Heat, with Radiant Floor Stage and Floor Warming, and Aux Heat Stage
- 2-Pipe FCU with 1 or 2 Stage Cool, with Radiant Floor Stage and Floor Warming, and Aux Heat Stage
- 4-Pipe FCU with 1 Stage Heat/Cool, with Radiant Floor Stage and Floor Warming, and Aux Heat Stage

## NOTES:

- **2-stage heating:** Unlike traditional furnaces that turn on and run at full capacity with each demand for heating, 2-stage heat operates like two separate furnaces to maintain a more consistent temperature in the home. The unit starts out running in its first stage, and operates at a fraction of its heating capacity. This reduced capacity is sufficient to warm the home on mild winter days. But when the temperature outside goes very low, the furnace adjusts to full capacity (second stage) to meet the demand for heat within the home.
- **2-stage cooling:** In warm weather, the first stage of the cooling equipment operates at a fraction of the total cooling capacity. On very hot days, the second stage of the cooling equipment energizes, and the cooling system operates at full capacity.

# Specifications

Product specifications for the HZ-THSTAT.

## Product Specifications

### Measurement Range

---

<b>Indoor Temperature</b>	32° to 110°F (0° to 43°C); Provided by local or remote temperature sensor
<b>Outdoor Temperature</b>	-40° to 170°F (-40° to 77°C); Provided by remote temperature sensor

**NOTE:** Outdoor temperature measurement is -30° to 120°F (-34° to 49°C) if thermistor sensors are used.

<b>Temperature Tolerance</b>	±1°F (±0.5°C)
<b>Humidity</b>	0% to 100% RH; Provided by local or remote temperature sensor
<b>Humidity Tolerance</b>	± 5.0% RH

### Setpoint Range

---

<b>Auto</b>	38° to 99°F (3° to 37°C)
<b>Heat</b>	38° to 89°F (3° to 32°C)
<b>Cool</b>	38° to 99°F (3° to 37°C)
<b>Radiant Floor</b>	38° to 110°F (3° to 43°C)
<b>Humidity</b>	5% to 90% RH

### Power Requirements

---

<b>Power Consumption</b>	2.5 W @ 24VAC
<b>Max Current per Relay</b>	1A
<b>Max current Across All Relays</b>	3A

### Communications

---

<b>Wi-Fi® communications</b>	802.11/b/g/n (2.4 GHz)
------------------------------	------------------------

### Controls

---

<b>Up</b>	Raises the room's setpoint by 1°F, 1°C, or 0.5°C, depending on the active temperature scale
-----------	---

**Down** Lowers the room's setpoint by 1°F, 1°C, or 0.5°C, depending on the active temperature scale

## Display

---

**Type** Transflective LCD, backlit  
**Size** 3.5 in. (89 mm)  
**Resolution** 320 x 480

## Connections

---

**C** (1) Common from HVAC system 24VAC transformer

**RH** (1) Reference, heat calls (W1/W2)

**R/RC** (1) Reference, compressor/cooling calls or single reference systems (Y/Y2/G/O/B)

**W** (1) Heat stage 1 call

**W2** (1) Heat stage 2 call

**Y** (1) Compressor stage 1 call

**Y2** (1) Compressor stage 2 call

**O** Non-FCU: (1) Changeover, active in cool mode;  
FCU: (1) Fan call (high)

**B** Non-FCU: (1) Changeover, active in non-cool modes;  
FCU: (1) Fan call (medium)

**G** Non-FCU: (1) Fan call;  
FCU: (1) Fan call (low)

**HUM** (1) Humidistat call

**HUMR** (1) Reference, humidistat call

**TS1+ and TS1-** (2) Remote sensor inputs, comprised of TS1+ and TS1- terminals;  
For remote temperature sensors ([CHV-RTS](#), [CHVI-RTS-1G-N-W](#), and [CHVI-RTS-1G-SM-W](#)), remote slab sensor ([CHV-RSS](#)), remote temperature and humidity sensors ([CHV-RTHS](#)), and 10k thermistors (all sensors and thermistors are sold separately);  
Connect up to (2) Crestron temperature sensors, (1) Crestron temperature/humidity sensor, or (1) 10k thermistor;  
Can be designated as an autochangeover sensor for an FCU 2-pipe heat/cool system

**NOTE:** TS1+ and TS1- connections are non-polarized. The + and - designations are provided to simplify wiring.

**TS2+ and TS2-** (2) Remote sensor inputs, comprised of TS2+ and TS2- terminals; For remote temperature sensors ([CHV-RTS](#), [CHVI-RTS-1G-N-W](#), and [CHVI-RTS-1G-SM-W](#)), remote slab sensor ([CHV-RSS](#)), remote temperature and humidity sensors ([CHV-RTHS](#)), and 10k thermistors (all sensors and thermistors are sold separately); Connect up to (2) Crestron temperature sensors, (1) Crestron temperature/humidity sensor, or (1) 10k thermistor; Can be designated as an autochangeover sensor for an FCU 2-pipe heat/cool system

**NOTE:** TS2+ and TS2- connections are non-polarized. The + and - designations are provided to simplify wiring.

**USB** (1) Micro B female, USB 2.0 computer console port for firmware upload, temporary power, and device configuration

### R CONNECTIONS Switch (on backplate)

**R/RC ONLY** For installations with only one R connection. Wire the R connection to the R/RC terminal.

**SEPARATE** For installations with separate RC and RH connections. Wire the RC connection to the R/RC terminal and the RH connection to the RH terminal.

### Sensors

**Ambient Light** Determines Day and Night mode, and sets auto dimming range for display and LED backlight

Backlight intensity is user adjustable

**Proximity** Day: More sensitive

Night: Less sensitive

### Environmental

**Temperature** 32° to 104°F (0° to 40°C)

**Humidity** 10% to 95% RH (noncondensing)

### Construction

**Housing** Plastic, surface-mountable to the front of a horizontally-oriented 1-gang electrical box

**Electrical Box Mounting (Preferred)** Mountable to a horizontal US-style, 1-gang new or old work electrical box with two mounting screws (included)

**Surface Mounting** Mountable to dry wall with two anchors (included)

Cutout template provided

**Mounting Depth** 1.50 in. (38 mm)

## Dimensions

---

<b>Height</b>	3.52 in. (89 mm)
<b>Width</b>	4.90 in. (124 mm)
<b>Depth</b>	1.76 in. (45 mm) overall; 0.57 in. (14 mm) from wall surface when installed

## Weight

---

7.81 oz (221 g)

## Compliance

---

**Regulatory Model: M201911001**

FCC Part 15 Class B, IC Class B, CE, and Intertek® Listed for US and Canada

# Dimensions

## Thermostat with Backplate Attached

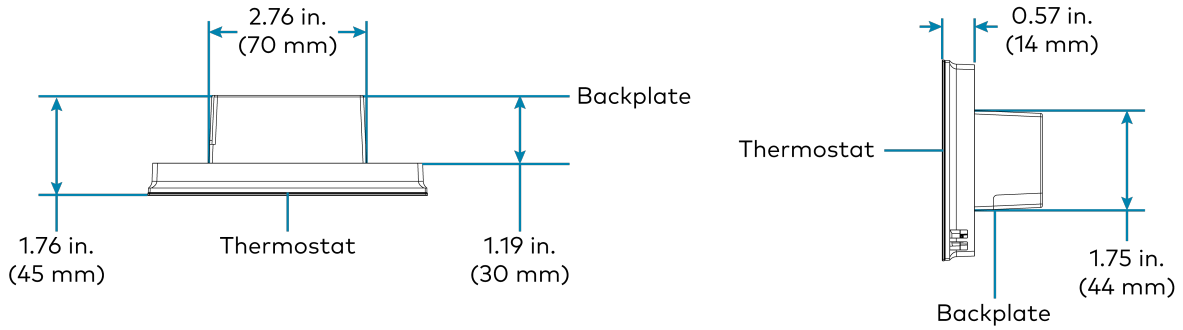

## Thermostat

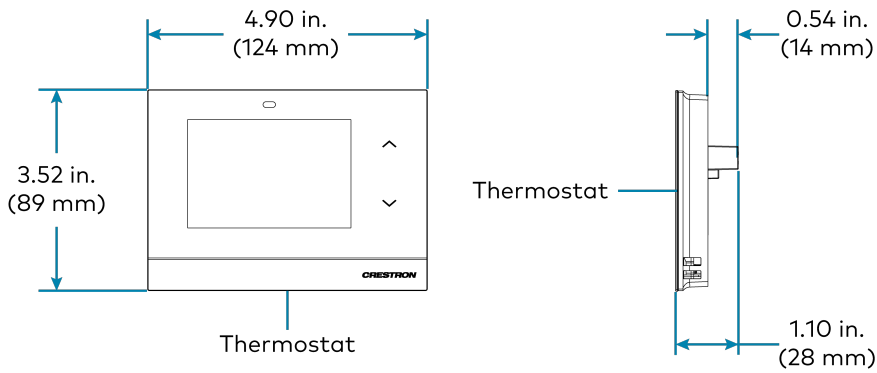

## Backplate

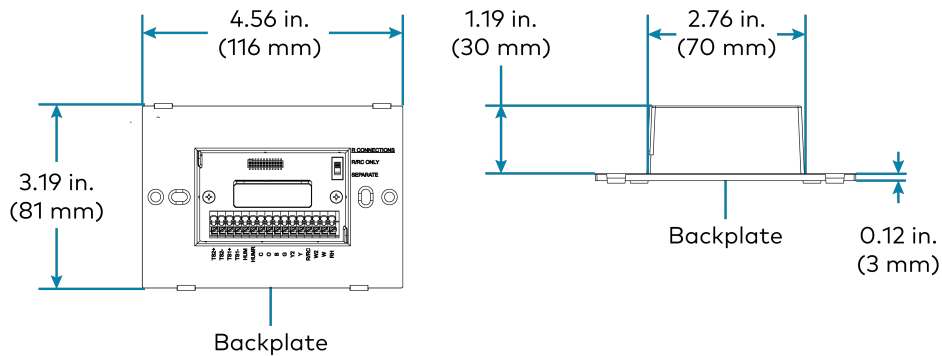

# Installation

This section provides the following information:

- [In the Box](#)
- [Equipment Required](#)
- [Determine the Mounting Location](#)
- [Mounting](#)
- [System Connections](#)
- [Wiring Diagrams](#)

# In the Box

---

1	HZ-THSTAT, Horizon® Wireless Thermostat
---	---

---

**Additional Items**

- |   |   |
|---|---|
| 2 | Anchor, Wall, Plastic, #6 x 1-1/4 in. (2043585)                             |
| 1 | Foam Insulation (2057585)   |
| 1 | Plate, Mounting with Terminal Block (4530666)                               |
| 2 | Screw, 6-32 x 3/4 in., Flat Head, Phillips (2055126)                        |
| 1 | Template, Cutout (4531679)  |
| 2 | Washer, Flat, Steel, #6 0.156 in. ID, 0.375 in. OD, 0.050 in. THK (2041707) |
-

# Equipment Required

The following tools and hardware are required for mounting the thermostat.

## New Electrical Box or Low Voltage Mounting Bracket

### Equipment included:

- Mounting screws
- Washers (not needed for low voltage mounting bracket)

### Equipment not included:

- Electrical box or low voltage mounting bracket
- Utility knife
- Level
- Stud finder
- Phillips screwdriver

## Existing Electrical Box or Low Voltage Mounting Bracket

### Equipment included:

- Mounting screws
- Washers (not needed for low voltage mounting bracket)

### Equipment not included:

- Phillips screwdriver

## Drywall

**NOTE:** A low voltage mounting bracket is recommended for retrofit drywall installations.

### Equipment included:

- Mounting screws
- Cutout template
- Drywall anchors

### Equipment not included:

- Utility knife
- Level
- Stud finder
- Phillips screwdriver

# Determine the Mounting Location

Install the thermostat away from direct sunlight, drafts, doorways, skylights, and windows. Also, make sure that the thermostat is conveniently located for control access and setup.

Follow the mounting requirements below:

- Mount 60 in. (~1.6 m) above the finished floor; this is an HVAC industry standard.
- On each side of the thermostat, allow at least 12 Xin. of lateral clearance to any wall features, such as corners or molding.
- Do not mount on an exterior wall.

A cutout template is included and a mounting depth of 1.50 in. (38 mm) is required.

# Mounting

Mount the thermostat to an electrical box, low-voltage mounting bracket, or to drywall. Electrical box mounting is preferred to isolate the thermostat from pressure or temperature differentials within the wall.

**NOTE:** For drywall installations, use the included drywall anchors. Make sure to use the outer screw holes on the back plate. For electrical box and low voltage mounting bracket (not included) installations, use the inner screw holes on the back plate.

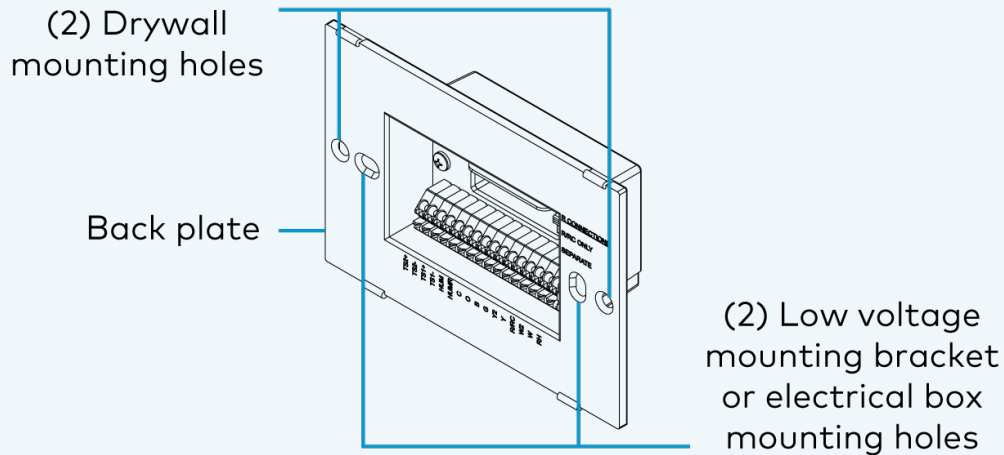

## Mount to an Electrical Box or Low Voltage Mounting Bracket

For applications with an existing electrical box or low voltage mounting bracket:

1. Turn the HVAC system power off.
2. If there is an existing thermostat, take a picture or label the existing wire configuration before removing the old thermostat.
3. Skip to step 7 in the following procedure.

To mount the thermostat to an electrical box or low voltage mounting bracket:

**NOTE:** Use a stud finder to avoid any studs behind the wall.

1. Turn the HVAC system power off.
2. Level the box or bracket and draw a cutout template for the appropriate size.  
For an electrical box, trace the outside of the box  
For the low voltage mounting bracket, trace the inside of the bracket or use the corner holes for markings.
3. Use a utility knife to cut around the outline of the drawn template.

- Keep retracing the outline cutting deeper until penetrating the back paper of the drywall. Clear away the excess drywall.

**NOTE:** Identify the wall type as Insulated (packed with insulation) or Non-Insulated (hollow). Assigning the wall type is necessary for Installer Settings configuration.

- Push the box or bracket through the mounting hole.
- Tighten the retaining screws until the box or bracket is held firmly in place.
- Pull the wires through the thermostat backplate, and push the backplate into the box or bracket.

**NOTE:** Always use the backplate that is shipped with the thermostat. When replacing a thermostat, do not reuse the backplate from the old thermostat.

- Using the mounting screws (included), secure the backplate to the box or bracket. Do not overtighten.

**NOTE:** Use the included washers to prevent overtightening when installing to a new work electrical box.

- Wire the backplate. Refer to [System Connections on page 24](#).
- Plug the wire hole on the back of the thermostat with the included foam insulation. Refer to [Wiring Diagrams on page 29](#).
- Attach the thermostat to the backplate.

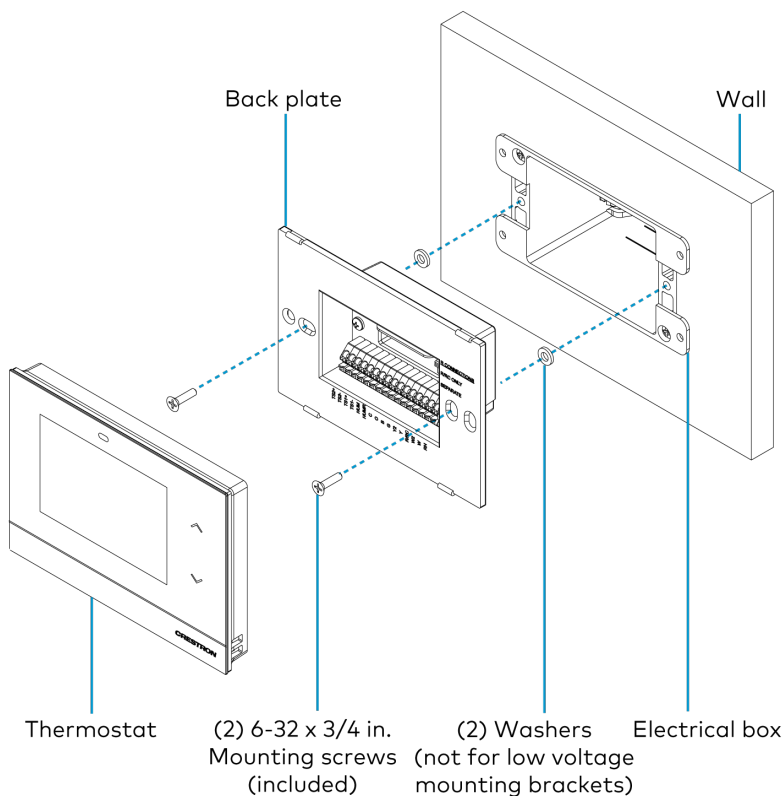

# Mount to Drywall

For retrofit applications replacing an existing thermostat, turn the HVAC system power off and take a picture or label the current wire configuration before dismantling the current thermostat.

**NOTES:** When replacing a thermostat that was mounted to drywall with anchors, it is recommended to perform one of the following:

- Mount the HZ-THSTAT 1 in. (26 mm) higher or lower than the existing thermostat to avoid interference between the new and old anchor positions.
- Mount the HZ-THSTAT using a low voltage mounting bracket (not included).

When mounting directly to drywall, use the included cutout template, a level (not included), and a utility knife (not included) to cut the mounting hole in the drywall.

## Cutout Template

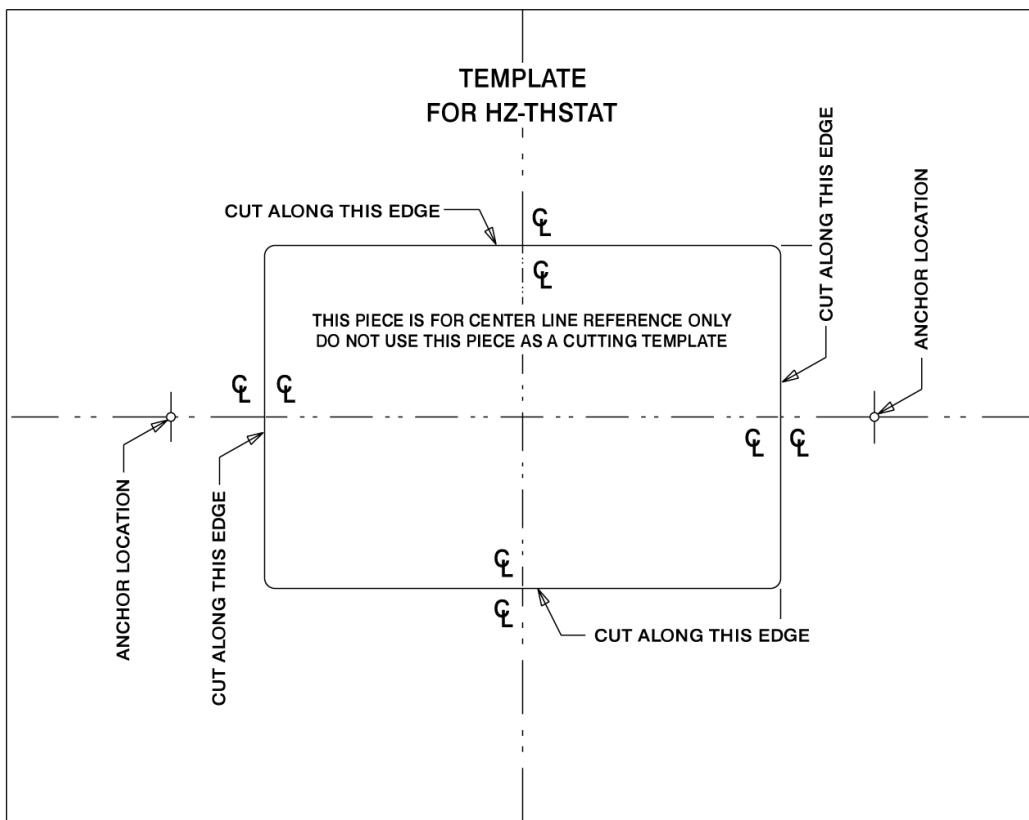

To mount the thermostat to drywall:

**NOTE:** Use a stud finder to avoid any studs behind the wall.

1. Turn the HVAC system power off.
2. Cut out the center rectangle of the included cutout template.
3. Level the cutout template against the mounting surface, and trace the inside rectangle.

4. Mark the anchor locations.
5. Use a utility knife to cut around the outline of the drawn template.
6. Keep retracing the outline cutting deeper until penetrating the back paper of the drywall. Clear away the excess drywall.

**NOTE:** Identify the wall type as Insulated (packed with insulation) or Non-Insulated (hollow). Assigning the wall type is necessary for Installer Settings configuration.

7. Screw in both self-tapping anchors (included) through the locations marked earlier.
8. Pull the wires through the thermostat backplate, and push the backplate into the mounting hole.

**NOTE:** Always use the backplate that is shipped with the thermostat. When replacing a thermostat, do not reuse the backplate from the old thermostat.

9. Using the mounting screws (included), secure the backplate to the anchors. Do not overtighten.
10. Wire the backplate. Refer to [System Connections on page 24](#).
11. Plug the wire hole on the back of the thermostat with the included foam insulation. Refer to [Wiring Diagrams on page 29](#).
12. Attach the thermostat to the backplate.

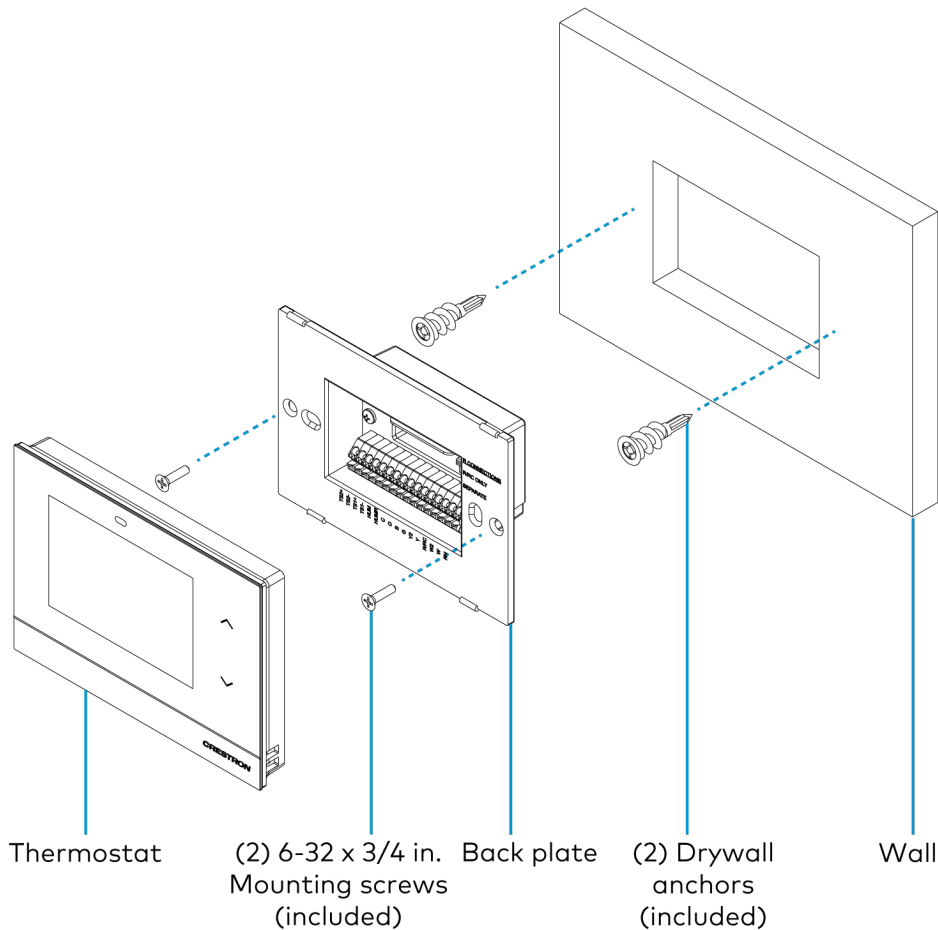

# System Connections

Use the connections on the backplate to wire the thermostat to the HVAC system.

Connection	Description
C	(1) Common from HVAC system 24VAC transformer. Used to power the device.
RH	(1) Reference for heat calls (W/W2) when using two separate reference connections. Used to power the device.
R/RC	(1) Reference for compressor/cooling/fan calls (Y/Y2/G/O/B). For single reference systems where the Reference Connections switch is set to R/RC ONLY, R/RC is also the reference for heat calls (W/W2). R/RC is also used to power the thermostat.
W	(1) Heat stage call. Energized to R/RC during a call for stage 1 heat (stage 2 heat when Radiant Floor is set to Space Heating) or aux heat 1 when Reference Connections switch is set to R/RC ONLY. If the Reference Connections switch is set to SEPARATE, W is energized to RH instead of R/RC ONLY.
W2	(1) Heat stage 2 call. Energized to R/RC during a call for stage 2 heat, aux heat 2, or radiant floor when the Reference Connections switch is set to R/RC ONLY. If the Reference Connections switch is set to SEPARATE, W2 is energized to RH instead of R/RC ONLY.
Y	(1) Compressor stage 1 call. Energized to R/RC during a call for stage 1 compressor when the Reference Connections switch is set to R/RC ONLY.
Y2	(1) Compressor stage 2 call. Energized to R/RC during a call for stage 2 compressor when the Reference Connections switch is set to R/RC ONLY.
O	Non-FCU: (1) Changeover, active in cool mode. Energized to R/RC during cooling modes when the Reference Connections switch is set to R/RC ONLY.; FCU: (1) Fan call (high). Energized to R/RC during cooling modes when the Reference Connections switch is set to R/RC ONLY.
B	Non-FCU: (1) Changeover, active in non-cool modes. Energized to R/RC during non-cooling calls when the Reference Connections switch is set to R/RC ONLY.; FCU: (1) Fan call (medium). Energized to R/RC during cooling modes when the Reference Connections switch is set to R/RC ONLY.
G	Non-FCU: (1) Fan call. Energized to R/RC during a fan call when the Reference Connections switch is set to R/RC ONLY.; FCU: (1) Fan call (low). Energized to R/RC during cooling modes when the Reference Connections switch is set to R/RC ONLY.
HUM	(1) Humidistat call. Energized to HUMR during a humidity call.
HUMR	(1) Reference, humidistat calls.

Connection	Description
TS1+ and TS1-	<p>(2) Remote sensor inputs, comprised of TS1+ and TS1- terminals;            For remote temperature sensors (<a href="#">CHV-RTS</a>, <a href="#">CHVI-RTS-1G-N-W</a>, and <a href="#">CHVI-RTS-1G-SM-W</a>), remote slab sensor (<a href="#">CHV-RSS</a>), remote temperature and humidity sensors (<a href="#">CHV-RTHS</a>), and 10k thermistors (all sensors and thermistors are sold separately);            Connect up to (2) Crestron temperature sensors, (1) Crestron temperature/humidity sensor, or (1) 10k thermistor;            Can be designated as an autochangeover sensor for an FCU 2-pipe heat/cool system</p>
	<p><b>NOTE:</b> TS1+ and TS1- connections are non-polarized. The + and - designations are provided to simplify wiring.</p>
TS2+ and TS2-	<p>(2) Remote sensor inputs, comprised of TS1+ and TS1- terminals;            For remote temperature sensors (<a href="#">CHV-RTS</a>, <a href="#">CHVI-RTS-1G-N-W</a>, and <a href="#">CHVI-RTS-1G-SM-W</a>), remote slab sensor (<a href="#">CHV-RSS</a>), remote temperature and humidity sensors (<a href="#">CHV-RTHS</a>), and 10k thermistors (all sensors and thermistors are sold separately);            Connect up to (2) Crestron temperature sensors, (1) Crestron temperature/humidity sensor, or (1) 10k thermisto;            Can be designated as an autochangeover sensor for an FCU 2-pipe heat/cool system</p>
	<p><b>NOTE:</b> TS2+ and TS2- connections are non-polarized. The + and - designations are provided to simplify wiring.</p>
USB	<p>(1) Micro B female, USB 2.0 computer console port for firmware upload, temporary power, and device configuration.</p>

**CAUTION:** To avoid a possible short circuit, ensure excess wire is pushed back through the hole in the backplate.

**NOTES:**

- This device is rated for 24VAC operation.
- For installations without a common wire, the [HZA-CONV-THSTAT-2WIRE](#) 2-wire power adapter (sold separately) may be used. For details, refer to [Wiring Diagrams on page 29](#).
- A miniature flathead screwdriver (not supplied) may be required to attach thinner gauged wires to the backplate terminals. Press the terminal release with the flathead screwdriver while inserting the wires.

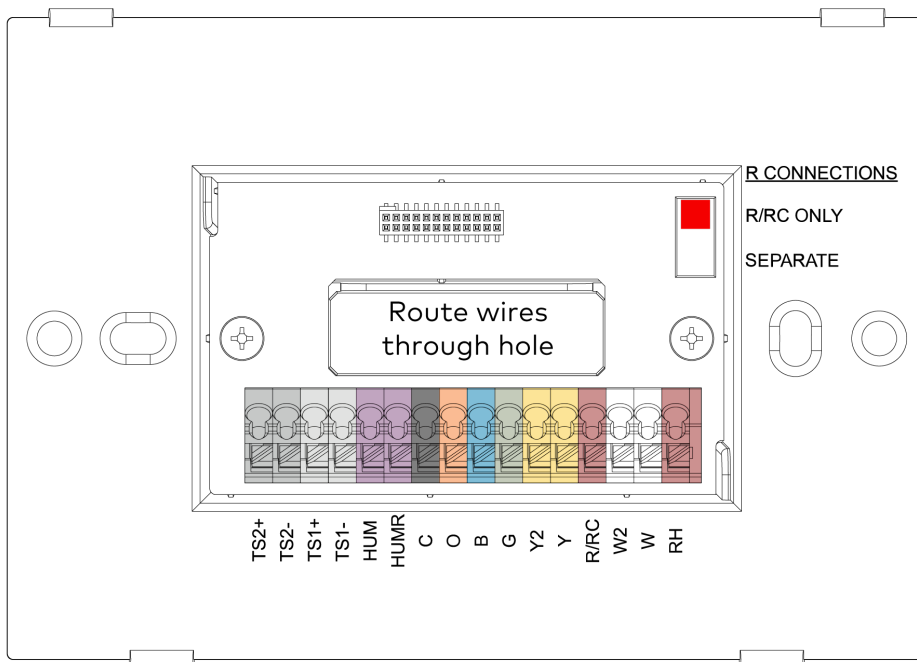

# R CONNECTIONS Switch

The thermostat pulls power from both R terminals and the C terminal. The position of the R Connections switch decides which R connection is routed to the heat calls (W/W2).

## NOTES:

- When using the HZA-CONV-THSTAT-2WIRE, always make connections to the R/RC terminals and set the switch to R/RC ONLY.
- When power is not available from the HVAC system, a separate 24VAC transformer can be connected between the RH and C terminals to provide power to the thermostat. Set the R Connections switch to R/RC ONLY to ensure all calls use the R/RC reference.

Before attaching the thermostat, note the position of the R CONNECTIONS switch.

- **One R connection (24VAC reference):** Wire to the **R/RC** terminal and set the switch to **R/RC ONLY**.
- **Two R connections (24VAC reference):** Wire to the **R/RC** and **RH** terminals and set the switch to **SEPARATE**.

The thermostat pulls power from both **R** connections and the **C** connection. The **R** Connections switch dictates which **R** connection is routed to the heat calls (W/W2). When power is not available from the HVAC system, a separate 24VAC transformer can be connected between the RH and C terminals to provide power to the thermostat, and the R Connection must be set to R/RC ONLY to ensure all calls use the R/RC reference.

**NOTE:** When using the HZA-CONV-THSTAT-2WIRE, always use R/RC terminal and set the R Connections switch to **R/RC ONLY**.

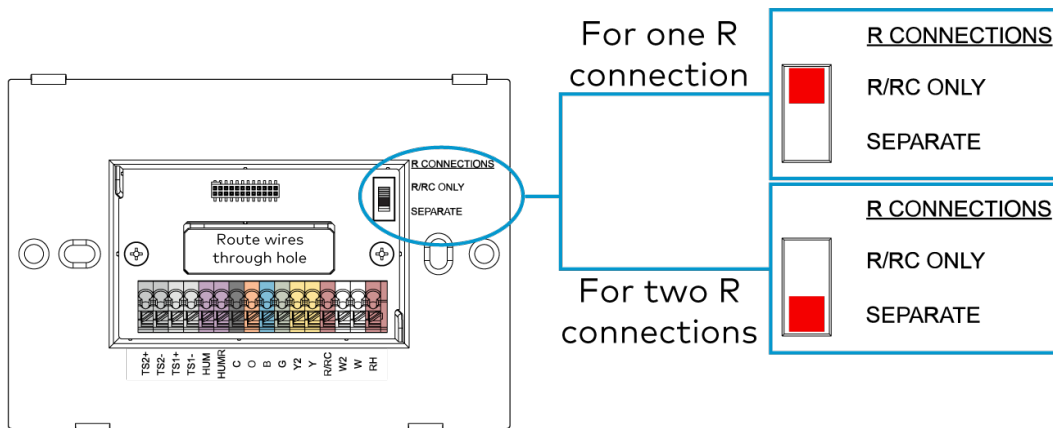

## Thermistor Curve

The thermostat is compatible with Crestron remote sensors and 10K thermistors. Refer to the table for information on the supported thermistor temperature curve.

Temperature	k-ohm
30°F (-1.1°C)	34.6
40°F (4.4°C)	26.1
50°F (10°C)	19.9
60°F (15.5°C)	15.3
70°F (21.1°C)	11.9
80°F (26.6°C)	9.4
90°F (32.2°C)	7.4
100°F (37.7°C)	5.9

# Wiring Diagrams

The following diagrams are a sampling of possible wiring solutions and do not represent all wiring options.

Refer to the [Glossary on page 186](#) for more information on the terms used in this section.

- [Single Stage Heat-Only System without Common Wire on page 31](#)
- [Single Stage Heat/Cool System without Common Wire on page 32](#)
- [Single Stage Heat/Cool System on page 33](#)
- [Single Stage Heat Pump with Aux Heat on page 34](#)
- [2 Stage Heat Pump with 2 Stage Aux Heat on page 35](#)
- [Dual Stage Heat/Cool System with Separate References and Humidification on page 36](#)
- [Wiring a Local Power Source on page 37](#)
- [Radiant Floor Only \(Floor Warming and/or Space Heating\) on page 38](#)
- [2 Stage Heat \(Stage 1 Radiant Floor\)/1 Stage Cool or 1 Stage Heat/1 Stage cool with Floor Warming on page 39](#)
- [2 Stage Heat \(Stage 1 Radiant Floor\)/1 Stage Cool Heat Pump with 1 Stage Aux Heat or 1 Stage Heat/1 Stage Cool Heat Pump with 1 Stage Aux Heat and Floor Warming on page 40](#)
- [3 Stage Heat \(Stage 1 Radiant Floor\)/2 Stage Cool Heat Pump with 1 Stage Aux Heat or 2 Stage Heat/2 Stage Cool Heat Pump with 1 Stage Aux Heat and Floor Warming on page 41](#)
- [2-Pipe FCU with 1 or 2 Stage Heat/Cool, with optional Radiant Floor Stage, optional Floor Warming, and optional Aux Heat Stage on page 42](#)
- [2-Pipe FCU with 1 or 2 Stage Heat, with optional Radiant Floor Stage, optional Floor Warming, and optional Aux Heat Stage on page 43](#)
- [2-Pipe FCU with 1 or 2 Stage Cool, with optional Radiant Floor Stage, optional Floor Warming, and optional Aux Heat Stage on page 44](#)
- [4-Pipe FCU 1 Stage Heat/Cool, with optional Radiant Floor Stage, optional Floor Warming, and optional Aux Heat Stage on page 45](#)

After wiring the thermostat, plug the wire hole on the back of the thermostat with the included foam insulation. The insulation prevents drafts and ensures accurate temperature readings.

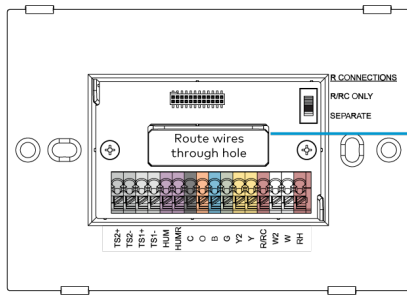

After routing the wires, plug the back of the hole with the foam insulation (included).

**NOTE:** For Radiant Floor, if the Radiant type is Floor Warming, Space Heating, or Floor Warm/Space Heat, always connect the radiant floor call wire to W2. Space Heating or Floor Warm/Space Heat will always use the radiant floor as the first stage of heat.

# Single Stage Heat-Only System without Common Wire

**NOTE:** This wiring is also applicable for a Radiant Floor Only (Floor Warming and/or Space Heating) system without Common Wire.

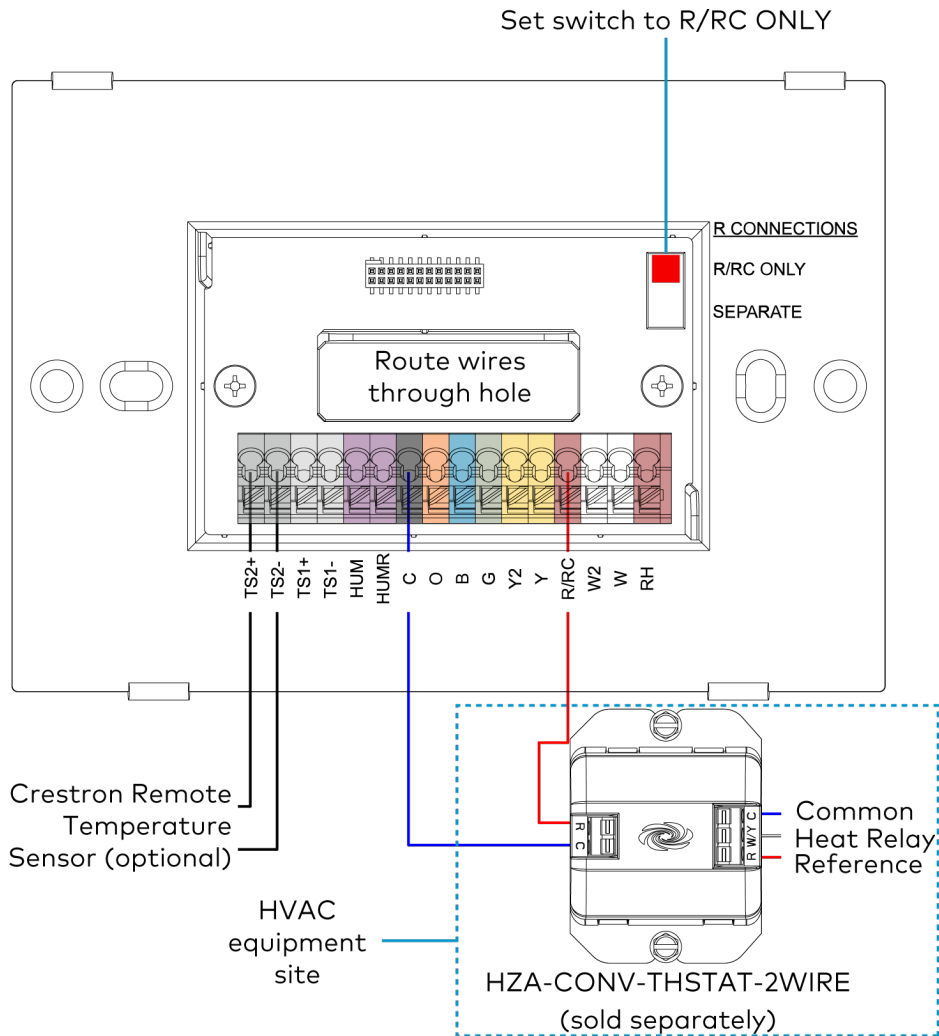

# Single Stage Heat/Cool System without Common Wire

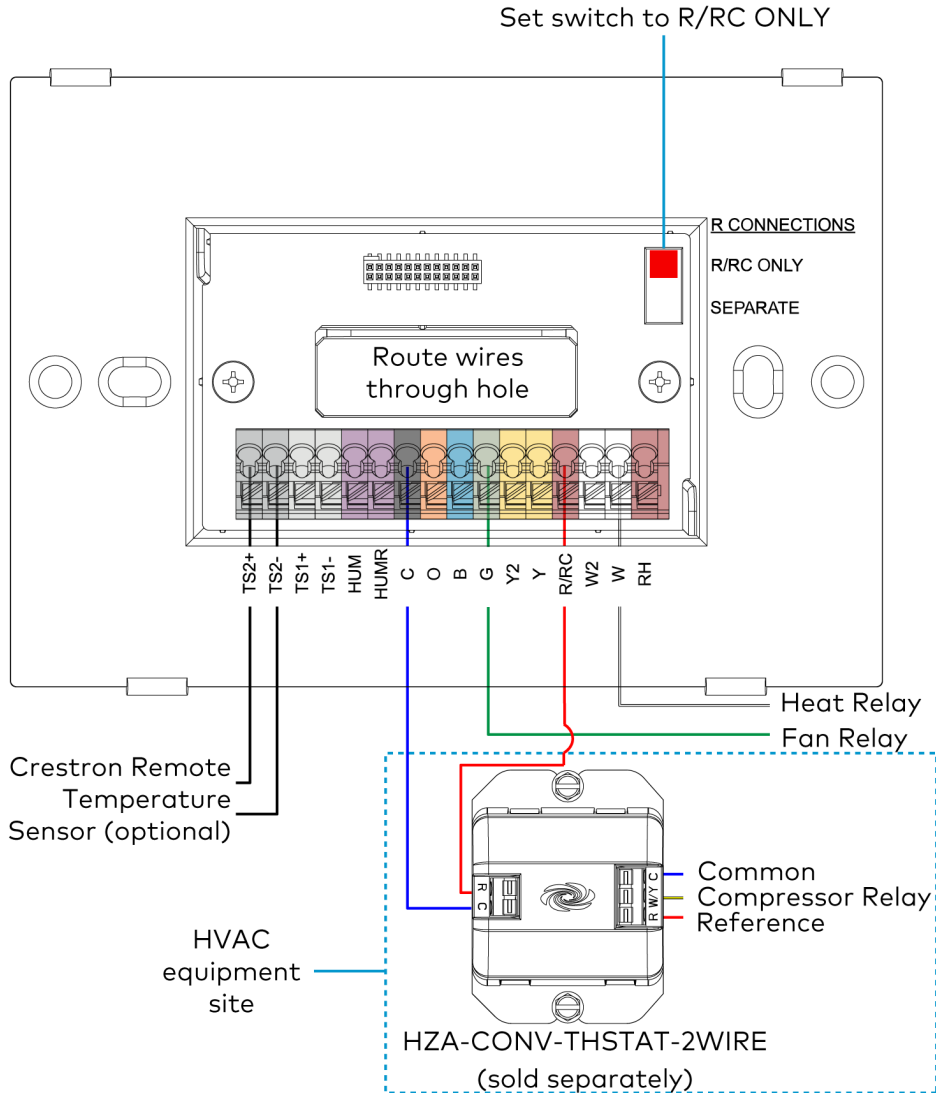

# Single Stage Heat/Cool System

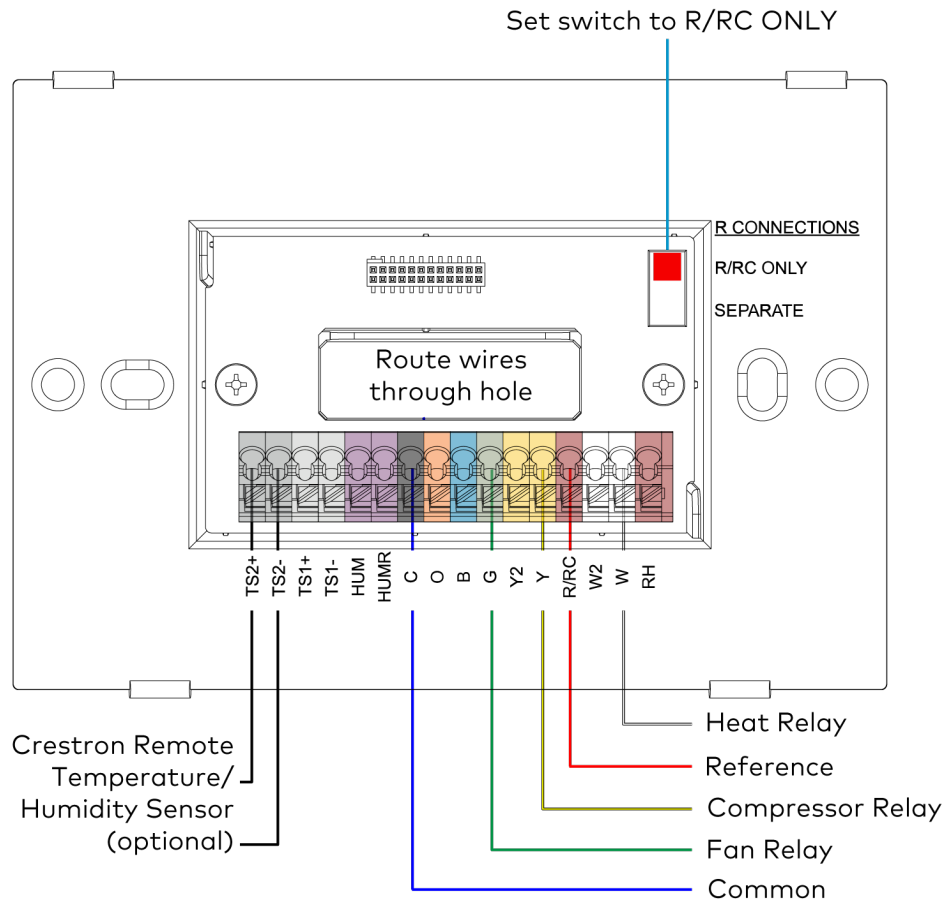

# Single Stage Heat Pump with Aux Heat

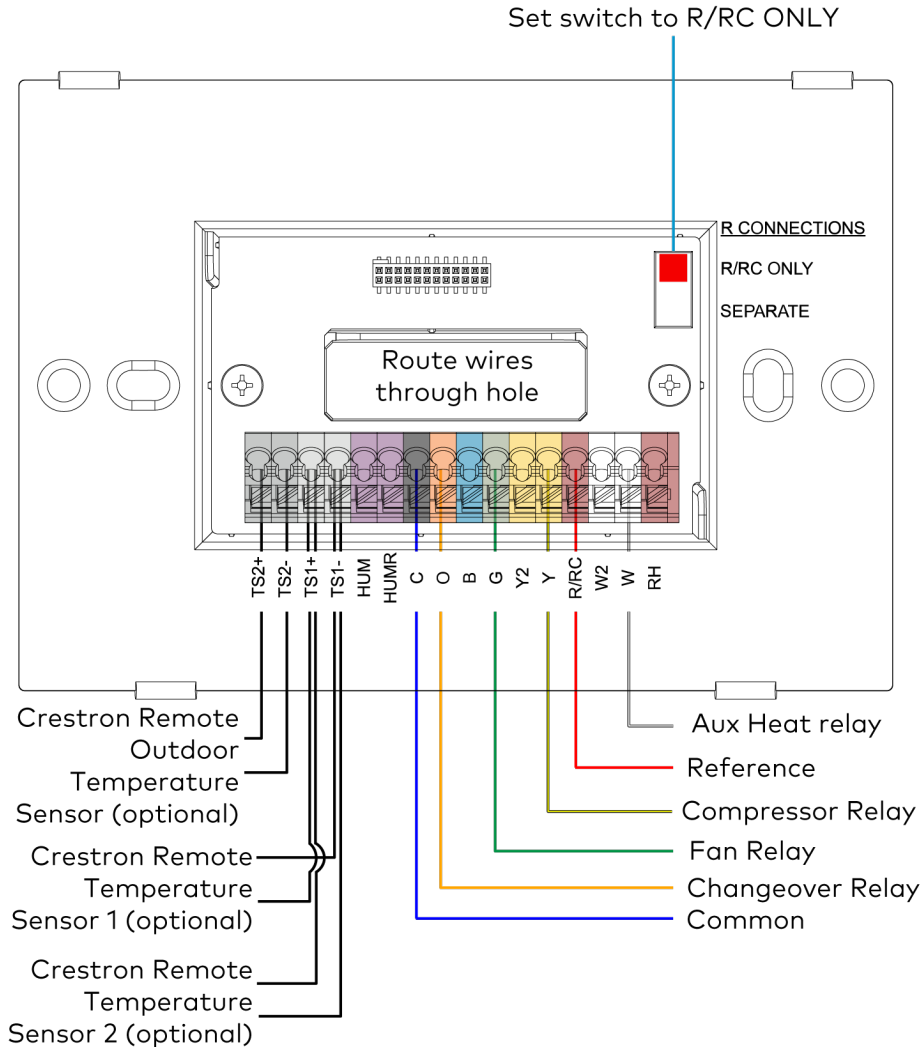

# 2 Stage Heat Pump with 2 Stage Aux Heat

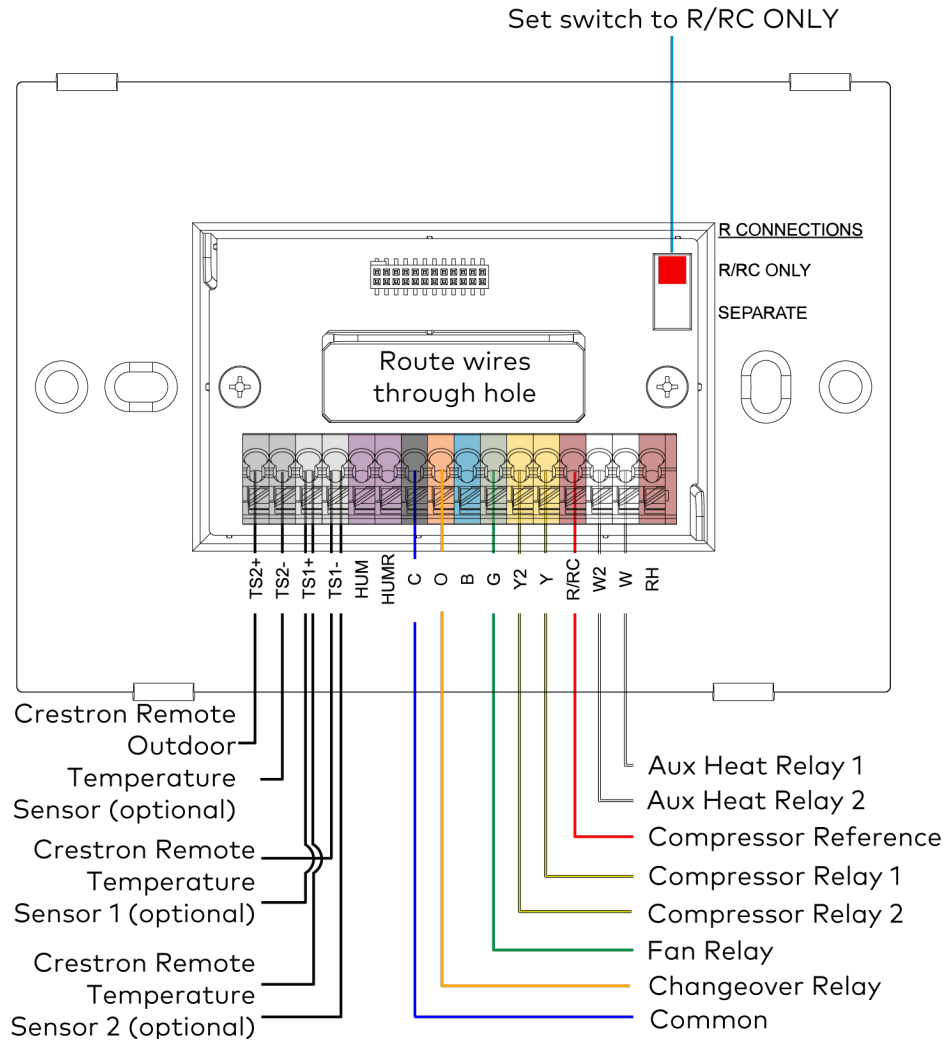

# Dual Stage Heat/Cool System with Separate References and Humidification

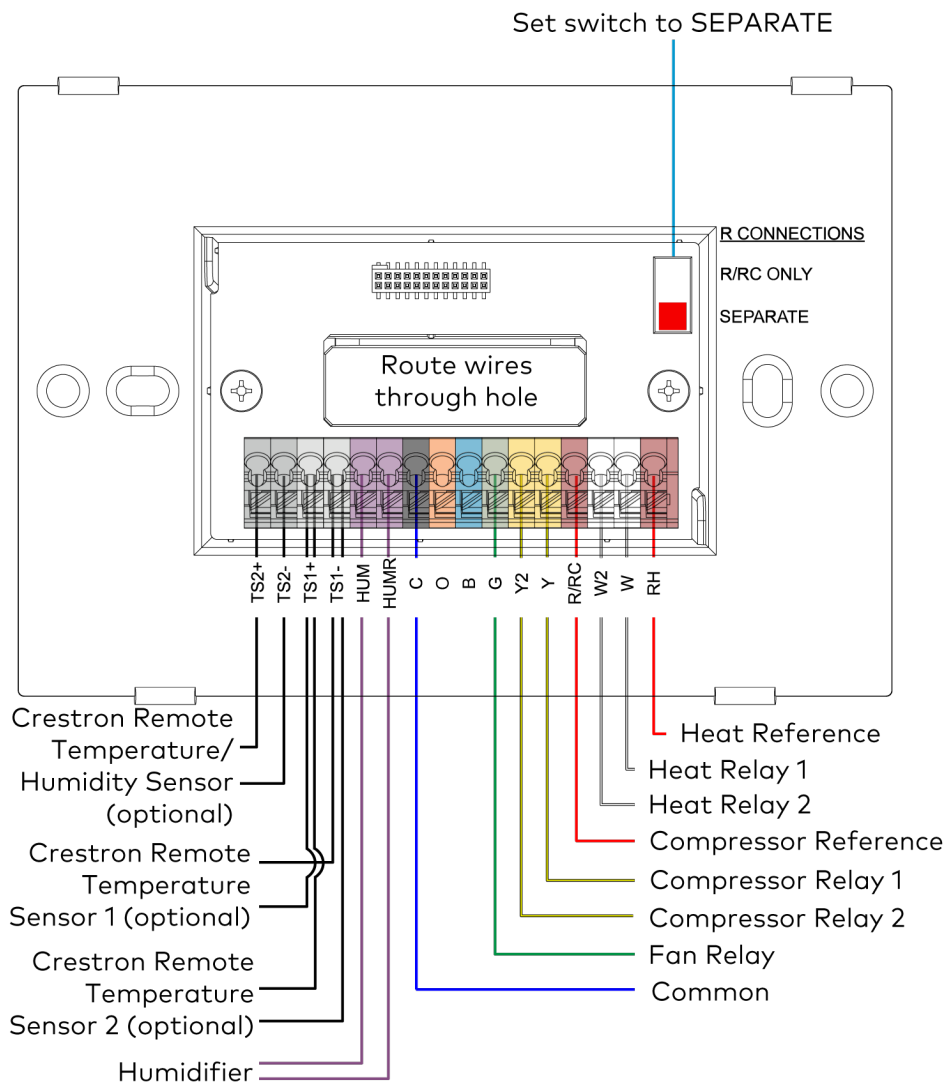

# Wiring a Local Power Source

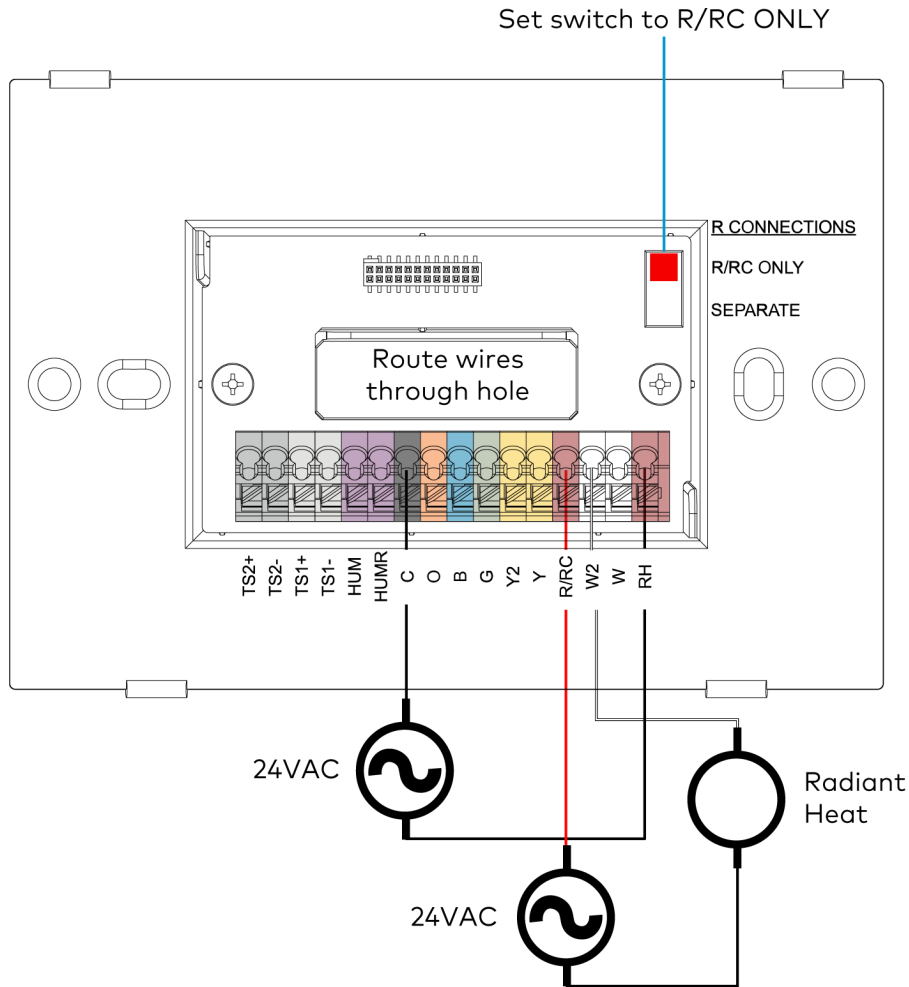

**NOTE:** If the HVAC system only requires one reference, a 24VAC power source can be used to power the device locally.

# Radiant Floor Only (Floor Warming and/or Space Heating)

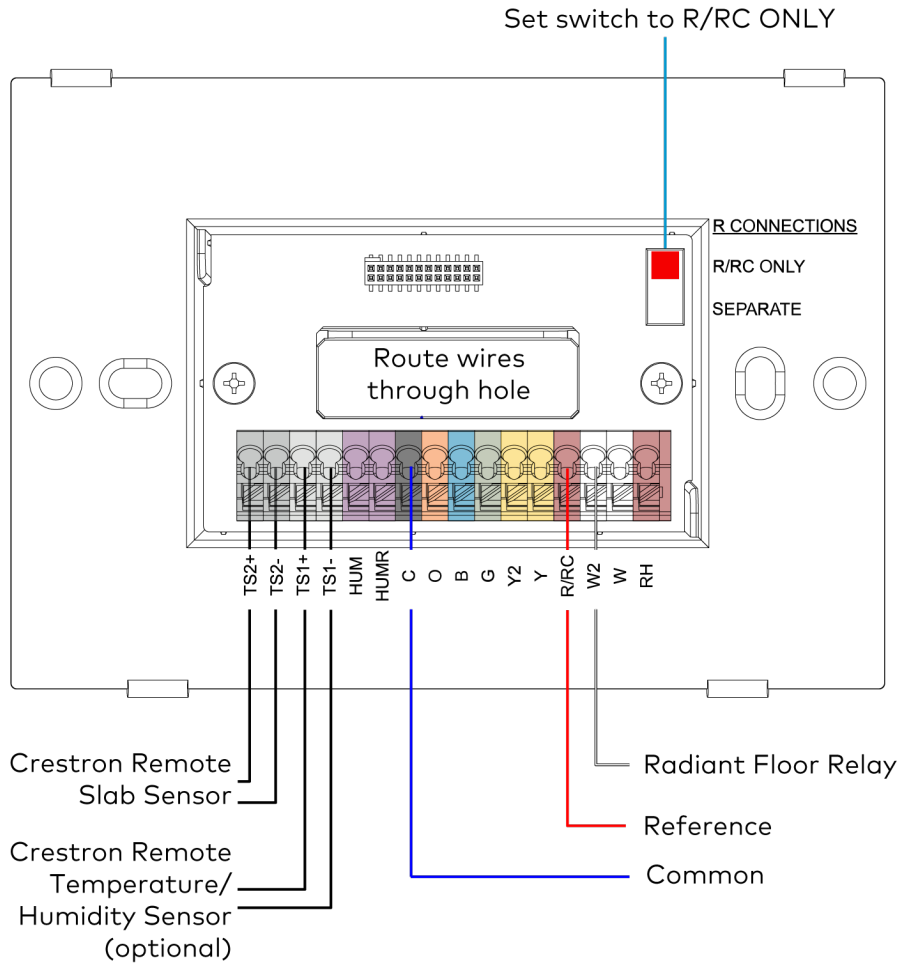

# 2 Stage Heat (Stage 1 Radiant Floor)/1 Stage Cool or 1 Stage Heat/1 Stage cool with Floor Warming

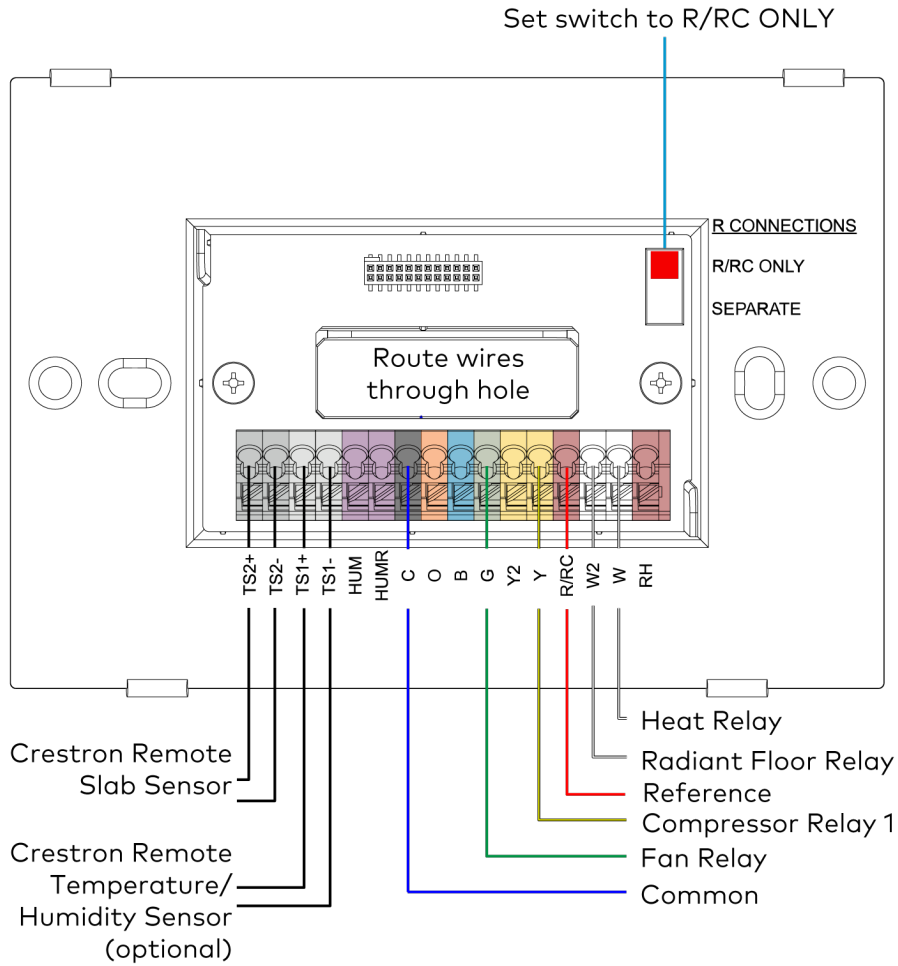

# 2 Stage Heat (Stage 1 Radiant Floor)/1 Stage Cool Heat Pump with 1 Stage Aux Heat or 1 Stage Heat/1 Stage Cool Heat Pump with 1 Stage Aux Heat and Floor Warming

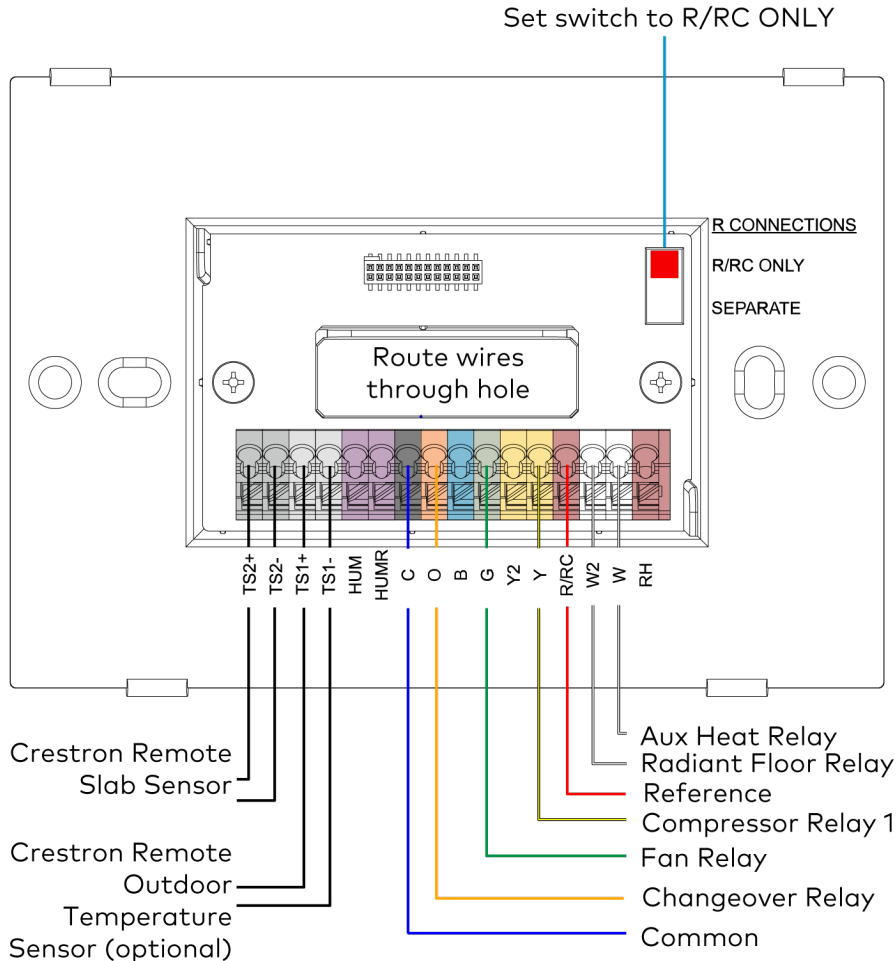

# 3 Stage Heat (Stage 1 Radiant Floor)/2 Stage Cool Heat Pump with 1 Stage Aux Heat or 2 Stage Heat/2 Stage Cool Heat Pump with 1 Stage Aux Heat and Floor Warming

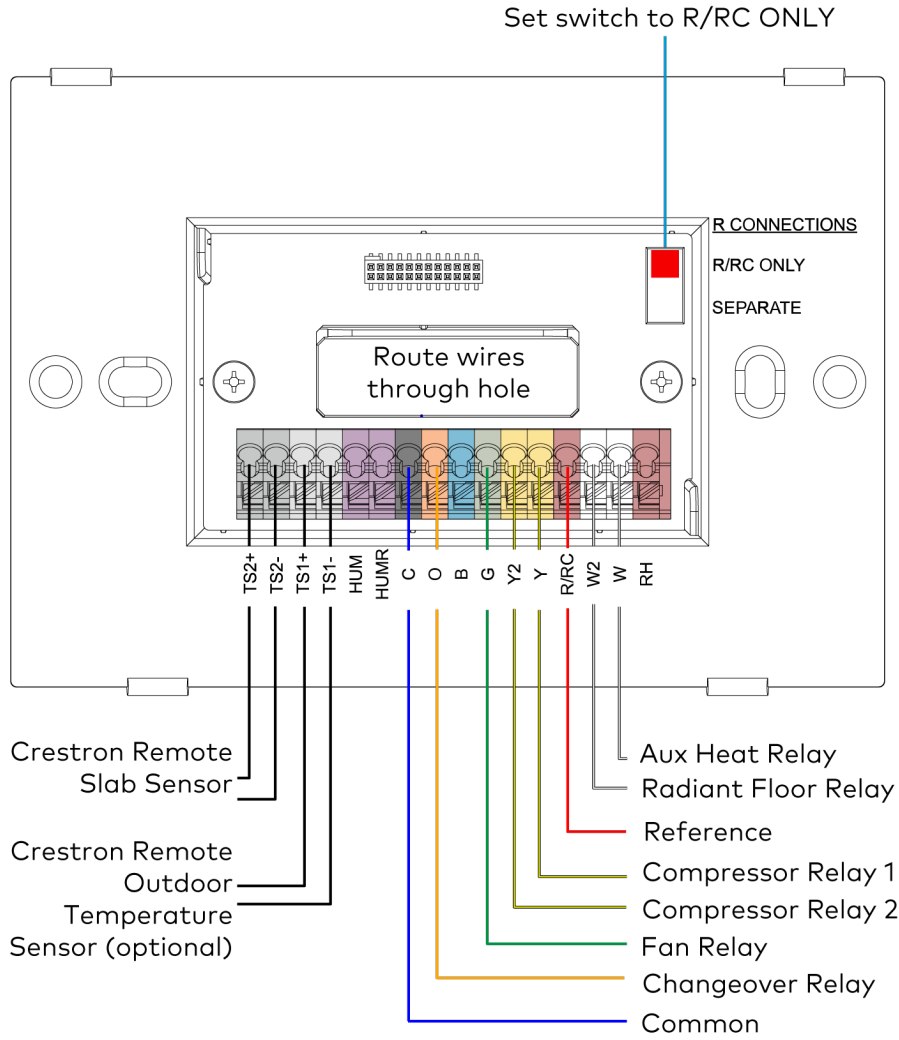

# 2-Pipe FCU with 1 or 2 Stage Heat/Cool, with optional Radiant Floor Stage, optional Floor Warming, and optional Aux Heat Stage

**NOTE:** When using auxiliary heat or radiant heat, either can be connected using a separate reference or the same reference as the FCU.

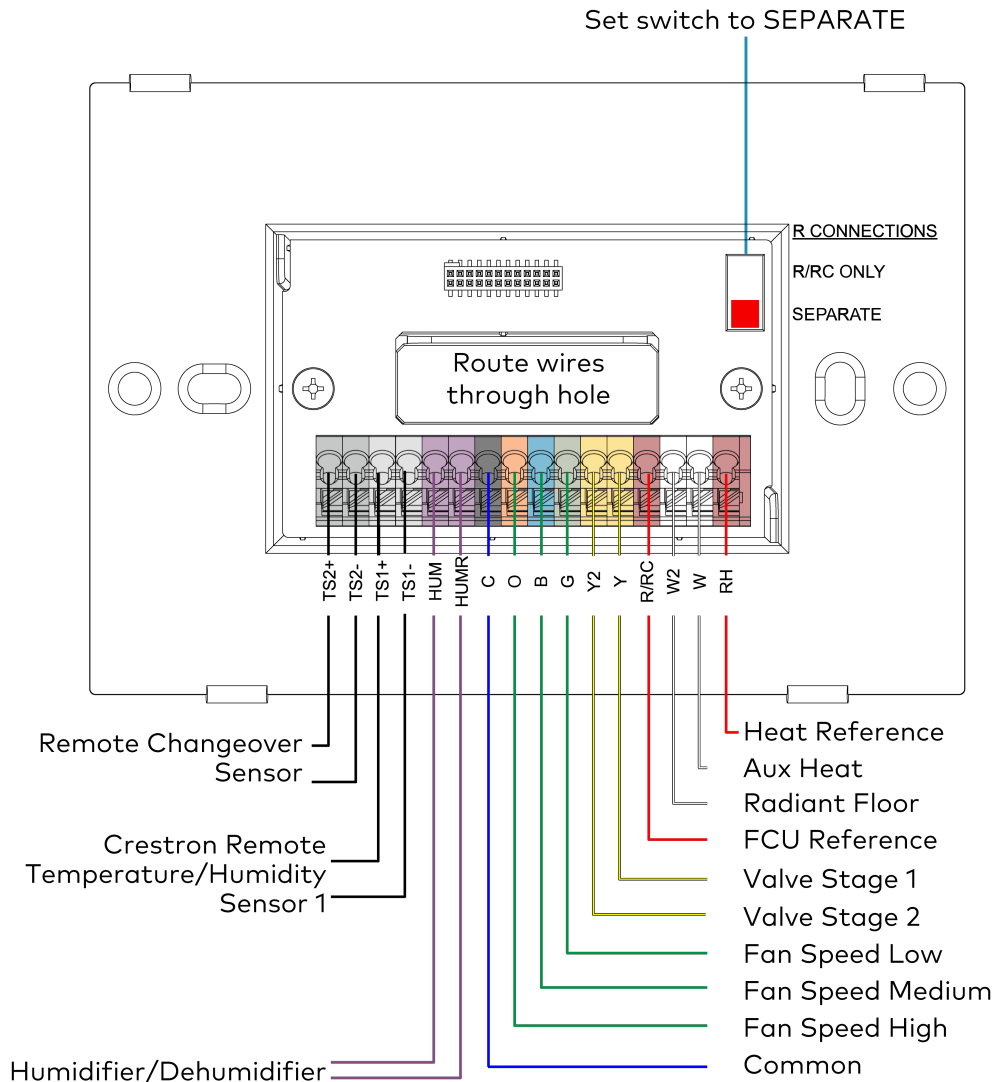

# 2-Pipe FCU with 1 or 2 Stage Heat, with optional Radiant Floor Stage, optional Floor Warming, and optional Aux Heat Stage

**NOTE:** When using auxiliary heat or radiant heat, either can be connected using a separate reference or the same reference as the FCU.

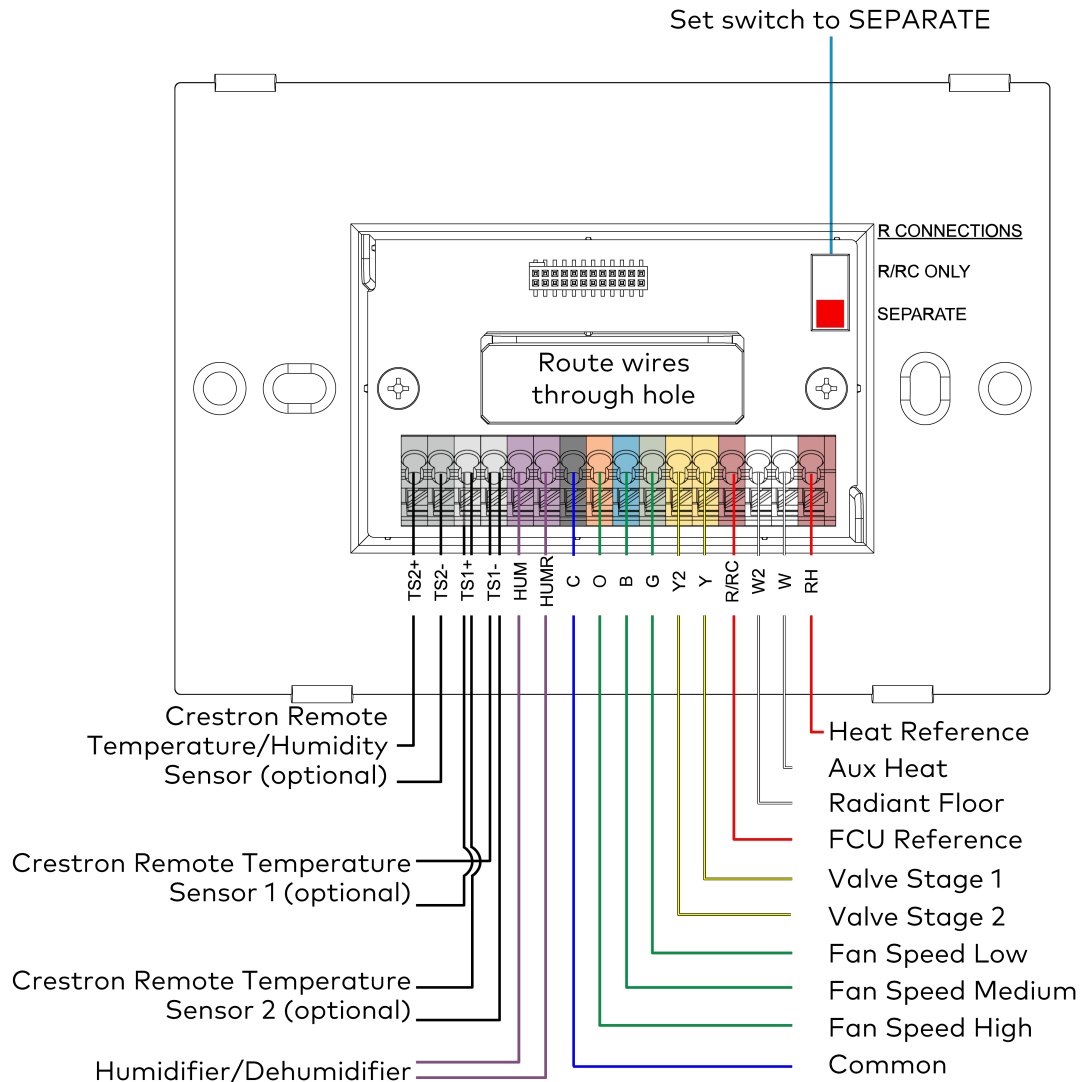

# 2-Pipe FCU with 1 or 2 Stage Cool, with optional Radiant Floor Stage, optional Floor Warming, and optional Aux Heat Stage

**NOTE:** When using auxiliary heat or radiant heat, either can be connected using a separate reference or the same reference as the FCU.

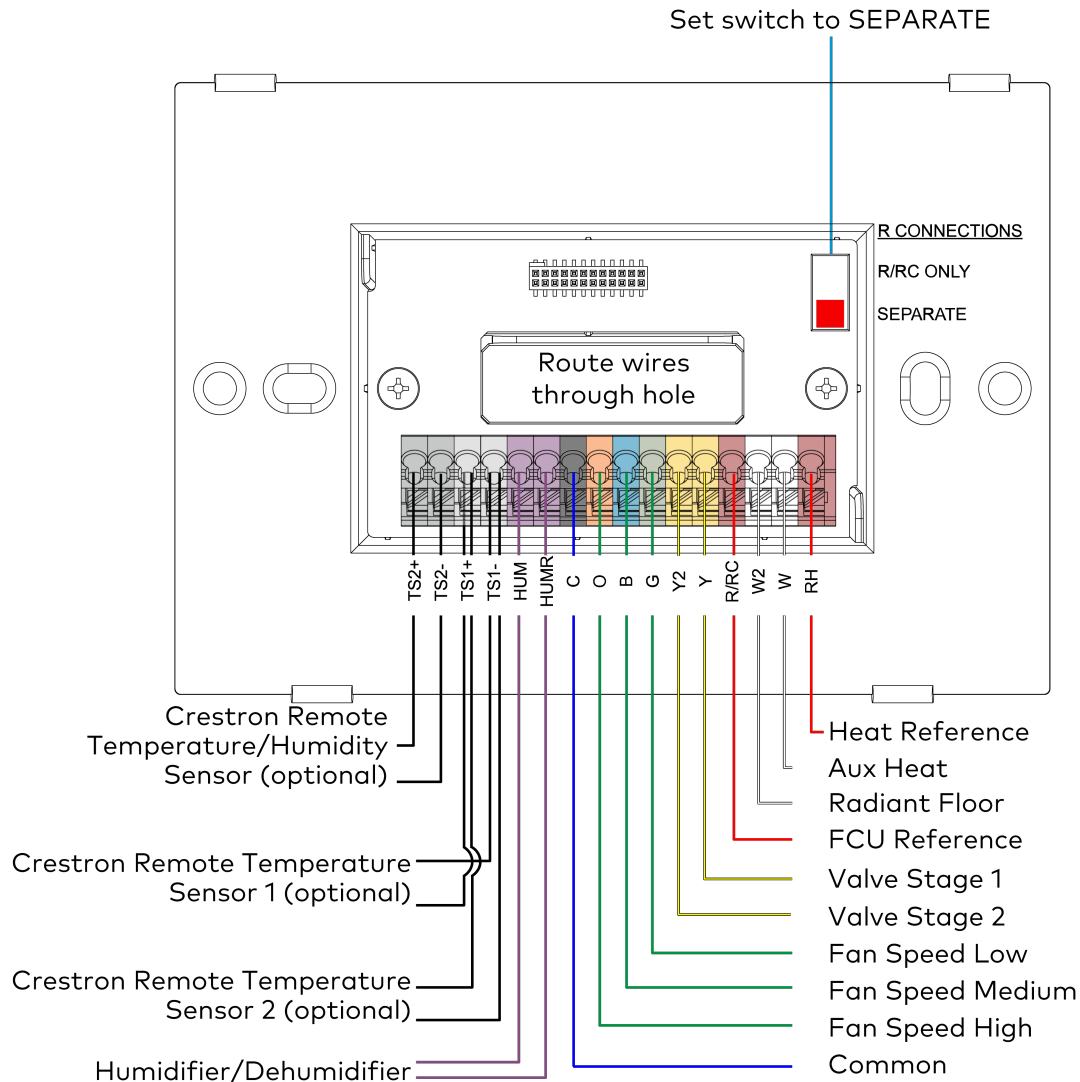

# 4-Pipe FCU 1 Stage Heat/Cool, with optional Radiant Floor Stage, optional Floor Warming, and optional Aux Heat Stage

**NOTE:** When using auxiliary heat or radiant heat, either can be connected using a separate reference or the same reference as the FCU.

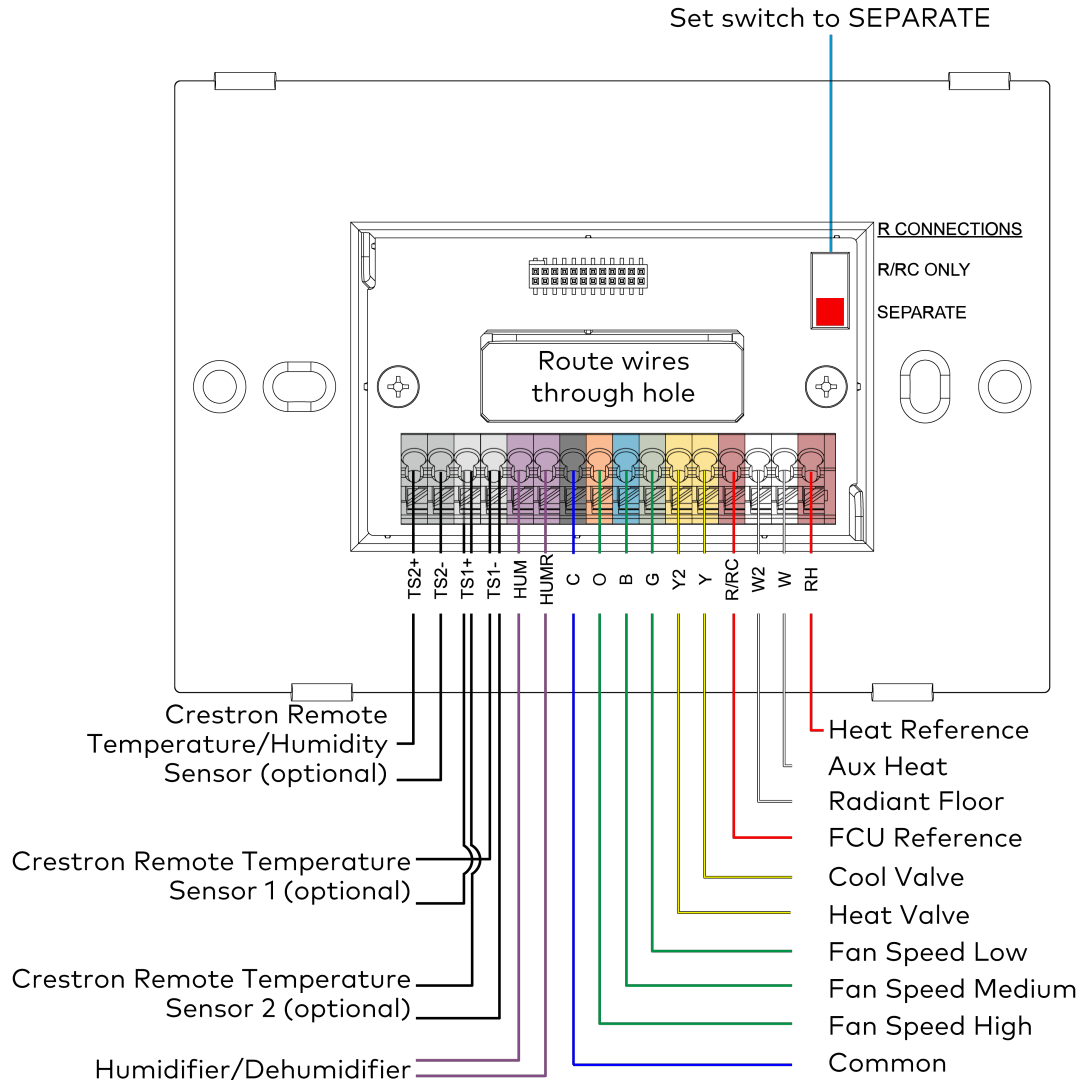

# Configuration

Before using the thermostat, ensure it is using the latest firmware. Check for the latest firmware at [www.crestron.com/firmware](http://www.crestron.com/firmware). Load the firmware onto the thermostat using Crestron Toolbox™ software.

Refer to the [Glossary on page 186](#) for more information on the terms used in this section.

This section provides the following information:

- [Remote Thermostat Configuration](#)
- [Local Thermostat Configuration](#)
- [Heat/Cool, 1 or 2 Stages, Forced Air or Radiant](#)
- [Heat Pump, 1 or 2 Stages, Aux Heat or Dual Fuel](#)
- [Radiant Floor Only \(Floor Warming\)](#)
- [Radiant Floor Only \(Space Heating\)](#)
- [Radiant Floor Only \(Floor Warming/Space Heating\)](#)
- [2 Stage Heat \(Stage 1 Radiant Floor\)/1 Stage Cool](#)
- [2 Stage Heat \(Stage 1 Radiant Floor\)/1 Stage Cool Heat Pump with 1 Stage Aux Heat](#)
- [2 Stage Heat \(Stage 1 Radiant Floor Warming/Space Heating\)/1 Stage Cool](#)
- [2 Stage Heat \(Stage 1 Radiant Floor Warming/Space Heating\)/1 Stage Cool Heat Pump with 1 Stage Aux Heat](#)
- [2-Pipe FCU with 1 or 2 Stage Heat/Cool, with optional Radiant Floor Stage, optional Floor Warming, and optional Aux Heat Stage](#)
- [2-Pipe FCU with 1 or 2 Stage Heat, with optional Radiant Floor Stage, optional Floor Warming, and optional Aux Heat Stage](#)
- [2-Pipe FCU with 1 or 2 Stage Cool, with optional Radiant Floor Stage, optional Floor Warming, and optional Aux Heat Stage](#)
- [4-Pipe FCU 1 Stage Heat/Cool, with optional Radiant Floor Stage, optional Floor Warming, and optional Aux Heat Stage](#)

# Remote Thermostat Configuration

Configure the HZ-THSTAT remotely using Crestron Toolbox™ software or the integrated web-based UI.

**TIP:** To configure the thermostat locally using the thermostat display, refer to [Local Thermostat Configuration on page 49](#).

Crestron Toolbox software and the web-based UI provide the following remote access configuration functions:

- **Crestron Toolbox Software:** Provides remote access to create a thermostat configuration, load thermostat configuration on one or more thermostats at a time, restart, factory restore, update firmware, download logs, and run diagnostics. The configuration options are the same as the local configuration options on the device.
- **Web-based UI:** Provides remote access to restart, factory restore, update firmware, and download logs.

## NOTES:

- Before using the thermostat, ensure it is using the latest firmware. Check for the latest firmware at [www.crestron.com/firmware](http://www.crestron.com/firmware). Load the firmware onto the thermostat using Crestron Toolbox™ software.
- The USB port on the back of the thermostat can be used to provide temporary power and to connect to the thermostat with Crestron Toolbox software.

# Crestron Toolbox Software Configuration

Use Crestron Toolbox™ software to configure and load a configuration to the HZ-THSTAT. The configuration can be loaded while onsite or remotely.

**NOTE:** When loading a configuration using the **Thermostat Configuration Tool**, a person must be onsite to accept the configuration using the touch screen on the HZ-THSTAT. This is to make sure that the configuration is sent to the correct thermostat and to prevent damage to the system.

To configure, use the **Thermostat Configuration Tool**. For details, refer to the [Crestron Toolbox software help](#) file.

To load a configuration, use the **Send to** feature in the **Thermostat Configuration Tool**. To accept a configuration, select **Yes, allow update** on the corresponding HZ-THSTAT device.

## HZ-THSTAT Remote Update Warning

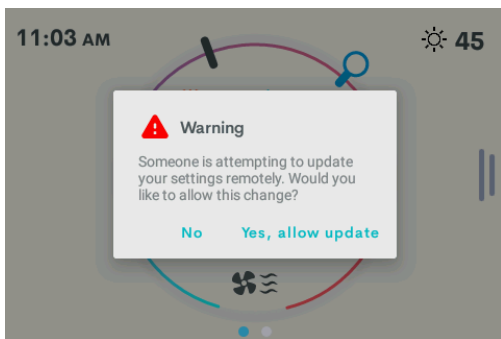

## Web-Based UI Configuration

To access the web-based user-interface:

1. Open a web browser and then go to the IP address of the HZ-THSTAT.
2. Enter the **Username** and **Password** and then select **Sign In**.

### NOTES:

- If prompted, create a Username and Password for the device.
- If the thermostat was added to a Crestron Home® system before the login credentials were created using the web UI or Crestron Toolbox software, log in using the common device username and password for the Crestron Home system:
  - "chdevice" is automatically populated in the username field.
  - The Common Device Password set in Crestron Home OS is automatically populated in the password field.
- If login credentials were created using the web UI or Crestron Toolbox software before the device was added to a Crestron Home system, log in using the credentials created in the web UI or Crestron Toolbox software or using the common device credentials for the Crestron Home system.

# Local Thermostat Configuration

Configure the HZ-THSTAT locally using the display on the thermostat. The thermostat can be configured using the Settings screens and the Installer Settings screens.

- **Settings:** Provides end-user access to settings for the display and wireless network. For details, refer to [Operation on page 164](#).
- **Installer Settings:** Provides installer access to settings and functions for System Configuration, End User Access, Display, Wireless Network, location, diagnostics, restart, factory restore, and device information.

**TIP:** To configure the thermostat remotely, refer to [Remote Thermostat Configuration on page 47](#).

To open the INSTALLER SETTINGS screen:

1. Swipe up from the bottom of the screen and then tap the gear icon.

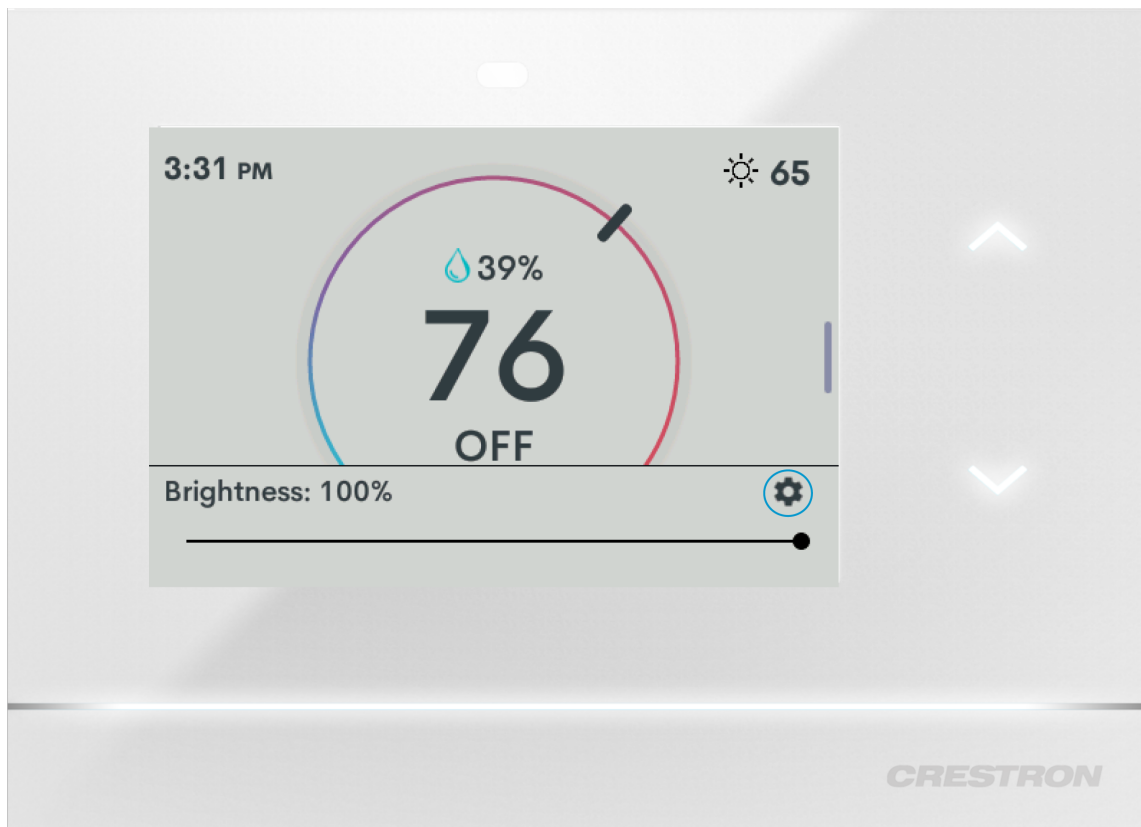

- Use the Up/Down buttons to enter the Installer Settings button sequence. Tap the **Up** button two times and then the **Down** button two times (**Up, Up, Down, Down**).

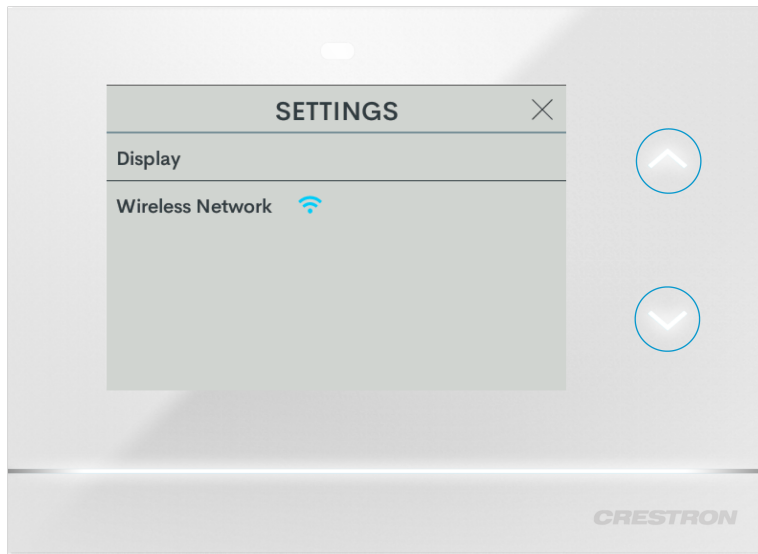

- The **INSTALLER SETTINGS** screen displays.

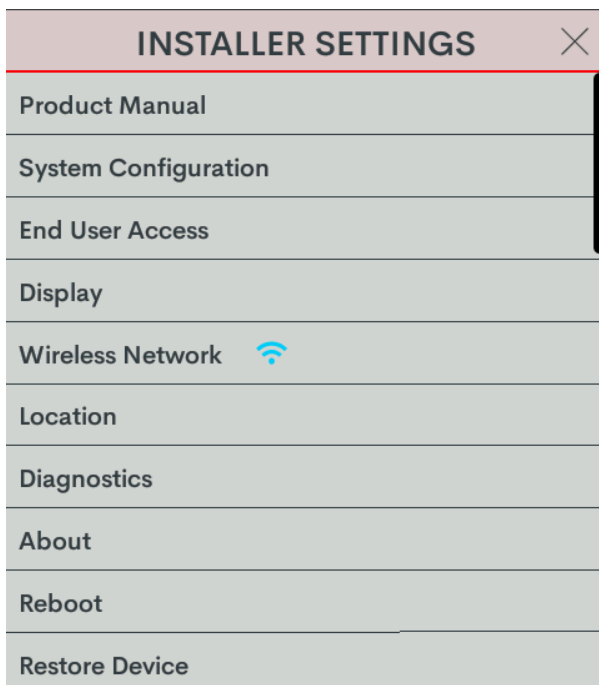

#### NOTES:

- Select **i Help** to view descriptions of settings throughout the setup screens. To close the Help window, select **Done**.
- Tap the orange arrow in the upper right-hand corner to move to the next screen.
- To close a setting screen, select X **Close** or swipe the screen top to bottom.

- As the thermostat is configured to match the HVAC system, settings options become active or inactive. The examples below illustrate how the active setting options can change depending on the options set by the user. For example, setting the Heat Stages or Cool Stages to 2 enables the Interstage Differential setting.

SYSTEM TYPE		SYSTEM PERFORMANCE	
1/2		1/3	
System Type	<input type="text" value="Heat/Cool"/>	Heat Anticipator	<input type="text" value="3"/>
Fan In Heat	<input type="text" value="No"/>	Cool Anticipator	<input type="text" value="3"/>
Heat Stages	<input type="text" value="1"/>	Interstage Diff	<input type="text" value="2.0"/>

  

SYSTEM TYPE		SYSTEM PERFORMANCE	
1/2		1/3	
System Type	<input type="text" value="Heat/Cool"/>	Heat Anticipator	<input type="text" value="3"/>
Fan In Heat	<input type="text" value="No"/>	Cool Anticipator	<input type="text" value="3"/>
Heat Stages	<input type="text" value="2"/>	Interstage Diff	<input type="text" value="2.0"/>

# Heat/Cool, 1 or 2 Stages, Forced Air or Radiant

Go to **Settings > Installer Settings > System Configuration** to open the **SYSTEM CONFIGURATION** screen.

Use the **System Type**, **System Performance**, **Radiant Floor**, **User Controls**, **Humidistat Setup**, and **Sensor Setup** options to configure the thermostat to work with the connected HVAC system.

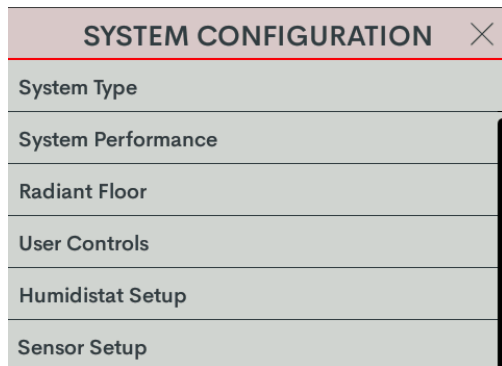

## System Type

Select **System Type** and then configure these settings:

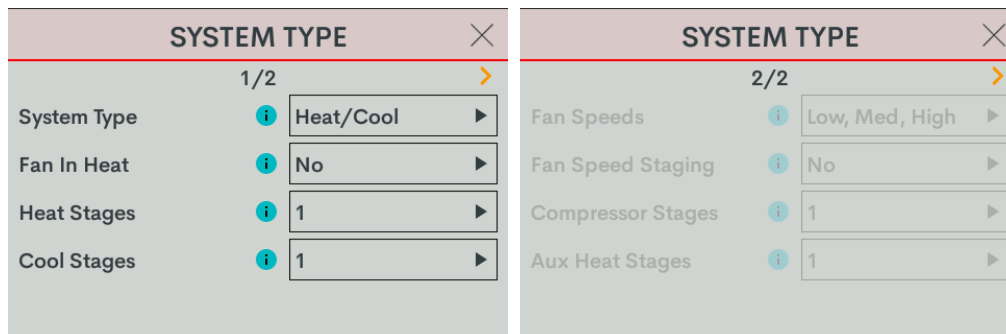

- **System Type:** Select **Heat/Cool**.

**NOTE:** There are Heat Only and Cool Only options for a Heat Only or Cool Only system type.

- **Fan In Heat:** Select **Yes** or **No** (default). Fan In Heat options change if **Heat Stages** is set to **2**. Select one of the following options:
  - **Yes:** Fan called for first and second stage (W/W2).
  - **W2 Only:** Fan called for second stage (W2) only.
  - **No:** Disable fan call operation for heat calls.

- **Cool Stages:** Number of cool-only (air conditioning) stages present. Select **1** (default) or **2**.
- **Heat Stages:** Number of heat-only stages present. Select **1** or **2**. Default setting: 1.

## System Performance

Select **System Performance** and then configure these settings:

The image displays three sequential screenshots of the 'SYSTEM PERFORMANCE' configuration screen. Each screen has a title bar with 'SYSTEM PERFORMANCE' and a close button (X). The first screen is labeled '1/3' and shows three settings: 'Heat Anticipator' with a value of 3, 'Cool Anticipator' with a value of 3, and 'Interstage Diff' with a value of 2.0. The second screen is labeled '2/3' and shows 'Accum. Staging Index' with a value of 3 and 'H.Pump Balance Point' with a value of 0. The third screen is labeled '3/3' and shows 'Short Cycle Timeout' with a value of 180 sec. and 'Aux Heat Balance Point' with a value of N/A.

- **Heat Anticipator:** Select **1, 2, 3** (default), **4, 5**, or **6**.  
For example, to adjust space heating system cycling characteristics, select **1** for more frequent cycles and faster responses or **6** for less frequent cycles and slower responses.
- **Cool Anticipator:** Select **1, 2, 3** (default), **4, 5**, or **6**.  
For example, to adjust cooling system cycling characteristics, select **1** for more frequent cycles and faster responses or **6** for less frequent cycles and slower responses.
- **Interstage Differential:** The proportional temperature error to trigger the next stage. Select **0.5 - 8.0** for Fahrenheit or **0.2 - 4.5** for Celsius. The default setting is **2.0** for Fahrenheit and **1.0** for Celsius.
- **Accumulated Staging Index:** Triggers the next stage to meet demand in instances where the previous stage cannot reach the Interstage Differential or achieve the desired setpoint. Select **1, 2, 3** (default), **4, 5**, or **6**.  
For example, select **1** for a faster trigger to the next stage or **5** for a slower trigger to the next stage. Setting 6 disables this feature altogether.
- **Short Cycle Timeout:** The minimum off time between system calls. Select **30 seconds, 60 seconds,** or **180 seconds** (default).

# User Controls

Select **User Controls** and then configure these settings:

The image displays five screenshots of the 'USER CONTROLS' menu, arranged in three rows. Each screenshot shows a different configuration step:

- Top Left:** '1/5' step. Shows 'Auto Setpoint' set to 'Dual', 'Setpoint Units' set to '1F', and 'Temp Display Offset' set to '0.0'.
- Top Right:** '2/5' step. Shows 'Heat' mode with 'Lower Setpoint' at 38 and 'Upper Setpoint' at 89. A note below the upper setpoint reads '(must be 10° Greater than Lower Setpoint)'.
- Middle Left:** '3/5' step. Shows 'Cool' mode with 'Lower Setpoint' at 59 and 'Upper Setpoint' at 99. A note below the upper setpoint reads '(must be 10° Greater than Lower Setpoint)'.
- Middle Right:** '4/5' step. Shows 'Auto' mode with 'Lower Setpoint' at 59 and 'Upper Setpoint' at 99. A note below the upper setpoint reads '(must be 10° Greater than Lower Setpoint)'.
- Bottom:** '5/5' step. Shows 'Auto Deadband' set to 2.0.

## NOTES:

- In Heat Only and Cool Only systems, the **Auto Setpoint** option is not available.
- In Cool Only systems, the **Heat Lower Setpoint** and **Heat Upper Setpoint** options are not available.
- In Heat Only systems, the **Cool Lower Setpoint** and **Cool Upper Setpoint** options are not available.
- In Heat Only or Cool Only systems or when **Auto Setpoint** is set to **Dual** or **Disable**, the **Auto Lower Setpoint** and **Auto Upper Setpoint** options are not available.
- In Heat Only or Cool Only systems or when **Auto Setpoint** is set to **Disable**, the **Auto Deadband** option is not available.

- **Auto Setpoint:** Defines how Auto mode operates. Select **Dual** (default) to use individual heat and cool setpoints, **Single** to use one setpoint for both heat and cool, or **Disabled** to turn off Auto mode.
- **Setpoint Units:** Defines the temperature scale and setpoint incrementation for the thermostat and sensors. Select **1F** (default), **1C**, or **0.5C**.
- **Temp Display Offset:** Adjusts an offset between the space temperature displayed and the temperature sensed. Select **-6** to **+6** for Fahrenheit or **-3.0** - **+3.0** for Celsius. The default setting is **0**.
- **Heat Lower Setpoint:** Limits the minimum heat setpoint the end user can set. Select **38 - 79** (Fahrenheit) or **3 - 27** (Celsius). The default setting is 38 (Fahrenheit) or 3 (Celsius)
- **Heat Upper Setpoint:** Limits the maximum heat setpoint the end user can set. The **Upper Setpoint** must be at least 10° (Fahrenheit) or 5° (Celsius) higher than the **Lower Setpoint**. Select **48 - 89** for (Fahrenheit) or **8 - 32** (Celsius). The default setting is 89 (Fahrenheit) or 32 (Celsius)
- **Cool Lower Setpoint:** Limits the minimum cool setpoint the end user can set. Select **38 - 89** (Fahrenheit) or **3 - 32** (Celsius). The default setting is 59 (Fahrenheit) or 15 (Celsius).
- **Cool Upper Setpoint:** Limits the maximum cool setpoint the end user can set. The **Upper Setpoint** must be at least 10° (Fahrenheit) or 5° (Celsius) higher than the **Lower Setpoint**. Select **48 - 99** for (Fahrenheit) or **8 - 37** (Celsius). The default setting is 99 (Fahrenheit) or 37 (Celsius).
- **Auto Lower Setpoint:** Limits the minimum auto setpoint the end user can set. Select **38 - 89** (Fahrenheit) or **3 - 32** (Celsius). The default setting is 59 (Fahrenheit) or 15 (Celsius).
- **Auto Upper Setpoint:** Limits the maximum auto setpoint the end user can set. The **Upper Setpoint** must be at least 10° (Fahrenheit) or 5° (Celsius) higher than the **Lower Setpoint**. Select **48 - 99** for (Fahrenheit) or **8 - 37** (Celsius). The default setting is 99 (Fahrenheit) or 37 (Celsius).
- **Auto Deadband:** This sets the separation between the heat and cool setpoints in Auto mode. In Dual Mode, this is the minimum separation allowed. Select **2.0** (default), **3.0**, **4.0**, **5.0**, or **6.0** for Fahrenheit or **1.0** (default), **2.0**, or **3.0** for Celsius.

# Sensor Setup

Select **Sensor Setup** and then configure these settings:

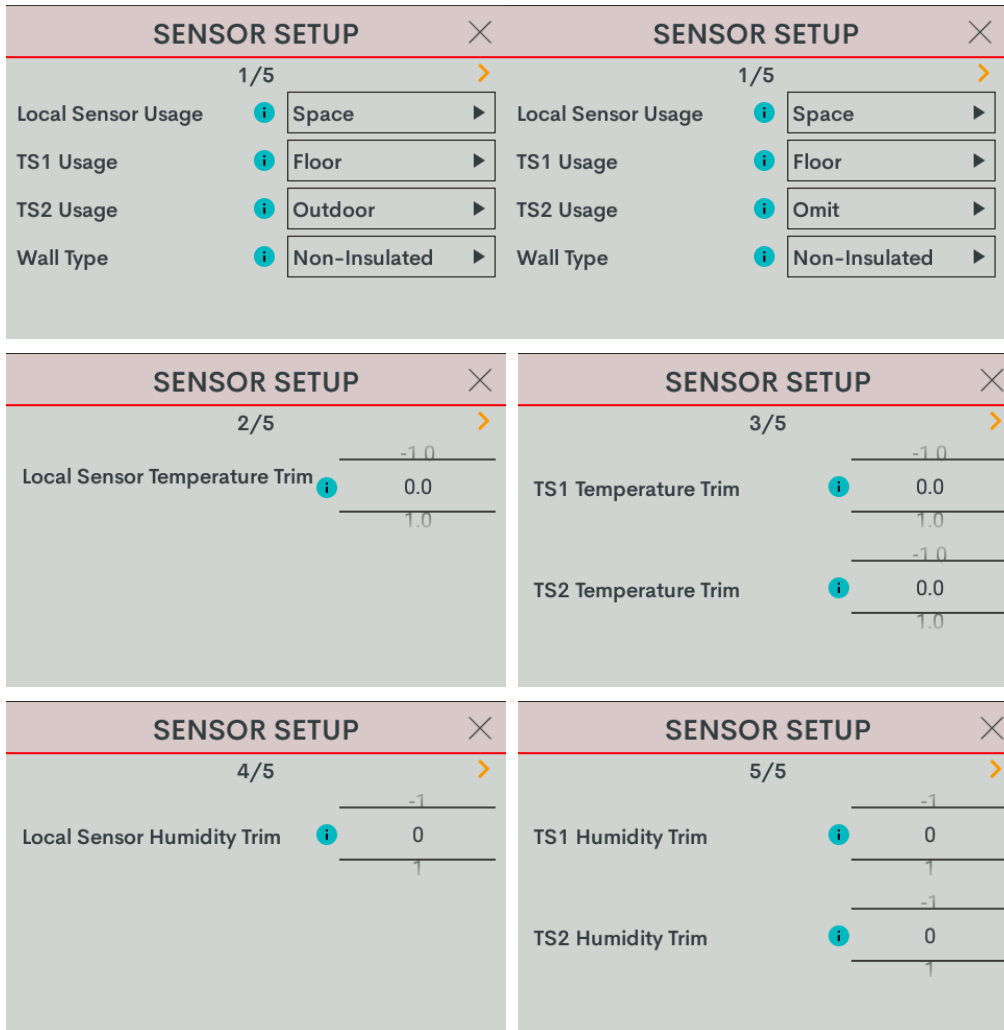

- **Local Sensor Usage:** Defines how the local sensor is used by the thermostat. Select **Omit** or **Space**.

- **Omit:** Omits channel from thermostat operation

**NOTE:** Sensor temperature and humidity can be output to the network even if Omit is selected.

- **Space:** Adds channel to space temperature/humidity average

- **TS1 Usage:** Defines how remote sensor channel 1 is used by the thermostat.
  - **Omit:** (Default) Omits channel from thermostat operation
  - **Space:** Adds channel to space temperature/humidity average
  - **Outdoor:** Adds channel to outdoor temperature/humidity average
  - **Floor:** Adds channel to slab (floor) temperature average
- **TS2 Usage:** Defines how remote sensor channel 2 is used by the thermostat.
  - **Omit:** (Default) Omits channel from thermostat operation
  - **Space:** Adds channel to space temperature/humidity average
  - **Outdoor:** Adds channel to outdoor temperature/humidity average
  - **Floor:** Adds channel to slab (floor) temperature average
- **Wall Type:** Defines the wall type that the thermostat is installed into for accurate temperature readings. Select **Non-Insulated** (hollow) or **Insulated**.
- **Local Sensor Temperature Trim:** Adjusts local sensor temperature measurement. Select **-6** to **+6** for Fahrenheit (**-3.0** to **+3.0** for Celsius). The default setting is **0**.
- **TS1 Temperature Trim:** Adjusts temperature sensed by temperature sensor(s) attached to TS1 input. Select **-6** to **+6** for Fahrenheit (**-3.0** to **+3.0** for Celsius). The default setting is **0**.
- **TS2 Temperature Trim:** Adjusts temperature sensed by temperature sensor(s) attached to TS2 input. Select **-6** to **+6** for Fahrenheit (**-3.0** to **+3.0** for Celsius). The default setting is **0**.
- **Local Sensor Humidity Trim:** Adjusts local sensor humidity percentage. Select **-9.0** to **+9.0**. The default setting is **0**.
- **TS1 Humidity Trim:** Adjusts humidity percentage sensed by temperature/humidity sensor attached to TS1 input. Select **-9.0** to **+9.0**. The default setting is **0**.
- **TS2 Humidity Trim:** Adjusts humidity percentage sensed by temperature/humidity sensor attached to TS2 input. Select **-9.0** to **+9.0**. The default setting is **0**.

## Humidistat Setup

Select **Humidistat Setup** and then configure these settings:

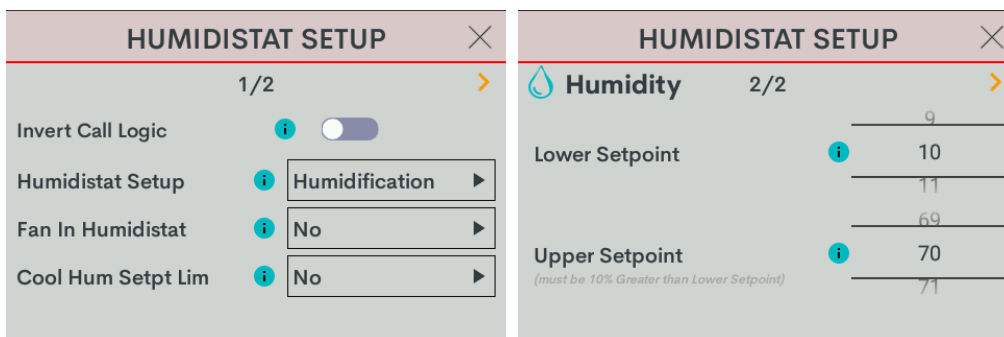

- **Invert Call Logic:** Change the HUM relay control logic for a humidifier or dehumidifier expecting a Normally Closed (NC) input. To invert the call logic, turn on the switch. The default setting is off for a Normally Open (NO) input.

- **Humidistat Setup:** Sets the operating mode of the HUM relay. Select **Humidification** (default), **Dehumidification**, or **Off**.
  - **Humidification:** Calls HUM relay when sensed humidity is below the humidistat setpoint.
  - **Dehumidification:** Calls HUM relay when sensed humidity is above the humidistat setpoint.
  - **Off:** Disable humidistat
- **Fan In Humidistat:** Select **No** (default) or **Yes**.

If **Yes**, the thermostat will make a fan call when a humidistat call is triggered instead of waiting for a heat or cool call to trigger the fan.
- **Cool Humidistat Setpoint Limit:** Limits internal humidistat setpoint to prevent window condensation when it is cold outside (displayed setpoint will not change). Select **No** (default) or **Yes**.
- **Lower Setpoint:** Limits the minimum humidistat setpoint percentage. Select **5 - 80**. The default setting is 10.
- **Upper Setpoint:** Limits the maximum humidistat setpoint percentage. Select **15 - 90**. The default setting is 70.

**NOTE:** The **Upper Setpoint** must be 10% higher than the **Lower Setpoint**.

# Heat Pump, 1 or 2 Stages, Aux Heat or Dual Fuel

Go to **Settings > Installer Settings > System Configuration** to open the **SYSTEM CONFIGURATION** screen.

Use the **System Type**, **System Performance**, **Radiant Floor**, **User Controls**, **Humidistat Setup**, and **Sensor Setup** options to configure the thermostat to work with the connected HVAC system.

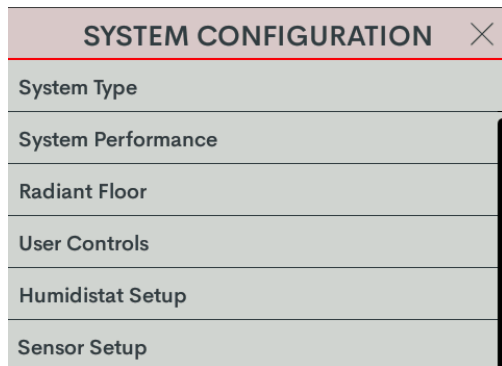

## System Type

Select **System Type** and then configure these settings:

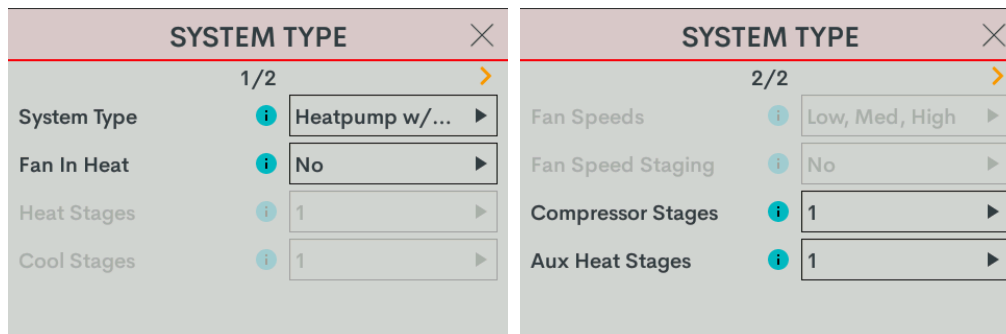

- **System Type:** Select **Heatpump w/ Aux** or **Dual Fuel Heatpump**.
- **Heat Pump w/ Aux** or **Dual Fuel Heat Pump:** Dual Fuel runs either the heat pump or the aux output, depending on outdoor temperature. The heat pump with aux can stage the heat when required to improve performance.
  - **Dual Fuel:** A dual fuel system combines an energy efficient air source heat pump with a new or existing oil, gas or propane furnace. The furnace runs in place of the heat pump in cold weather.
  - **Aux (Auxiliary) Heat:** When the a heat pump can no longer efficiently transfer heat from the outside air, the thermostat automatically turns on a secondary heat source, such as electric resistive heat.

- **Fan In Heat:** Select **Yes** or **No** (default). Fan In Heat options change if **Heat Stages** is set to **2**. Select one of the following options:
  - **Yes:** Fan called for first and second stage (W/W2).
  - **W2 Only:** Fan called for second stage (W2) only.
  - **No:** Disable fan call operation for heat calls.
- **Heat Pump Compressor Stages:** Number of heat pump compressor stages present. Choose **1** or **2**. Default setting: 1.
- **Heat Pump Auxiliary Stages:** Number of Auxiliary Heat stages present. Choose **1** or **2**. Default setting: 1.

## System Performance

Select **System Performance** and then configure these settings:

The image shows three sequential screenshots of the 'SYSTEM PERFORMANCE' configuration screen. Each screen has a title bar with 'SYSTEM PERFORMANCE' and a close button (X). A progress indicator (1/3, 2/3, 3/3) is shown at the top right of each screen.

- Screen 1 (1/3):** Shows 'Heat Anticipator' set to 3, 'Cool Anticipator' set to 3, and 'Interstage Diff' set to 2.0. Each setting has an information icon (i) and a right-pointing arrow.
- Screen 2 (2/3):** Shows 'Accum. Staging Index' set to 3 and 'H.Pump Balance Point' set to N/A. The H.Pump Balance Point has a numerical input field with '0' below it.
- Screen 3 (3/3):** Shows 'Short Cycle Timeout' set to 180 sec. and 'Aux Heat Balance Point' set to N/A. The Aux Heat Balance Point has a numerical input field with '0' below it.

- **Heat Anticipator:** Select **1, 2, 3** (default), **4, 5**, or **6**.  
For example, to adjust space heating system cycling characteristics, select **1** for more frequent cycles and faster responses or **6** for less frequent cycles and slower responses.
- **Cool Anticipator:** Select **1, 2, 3** (default), **4, 5**, or **6**.  
For example, to adjust cooling system cycling characteristics, select **1** for more frequent cycles and faster responses or **6** for less frequent cycles and slower responses.
- **Interstage Differential:** The proportional temperature error to trigger the next stage. Select **0.5 - 8.0** for Fahrenheit or **0.2 - 4.5** for Celsius. The default setting is **2.0** for Fahrenheit and **1.0** for Celsius.

- **Accumulated Staging Index:** Triggers the next stage to meet demand in instances where the previous stage cannot reach the Interstage Differential or achieve the desired setpoint. Select **1, 2, 3** (default), **4, 5**, or **6**.

For example, select **1** for a faster trigger to the next stage or **5** for a slower trigger to the next stage. Setting **6** disables this feature altogether.

- **Heat Pump Balance Point:** Minimum outdoor temperature at which the heat pump runs (requires an outdoor temperature source). Select N/A or **0 - 90** for Fahrenheit (**-18 - 31** for Celsius). Default setting: N/A.
- **Short Cycle Timeout:** The minimum off time between system calls. Select **30 seconds, 60 seconds,** or **180 seconds** (default).
- **Auxiliary Heat Balance Point:** Maximum outdoor temperature at which Auxiliary heat system supplements the heat pump (requires an outdoor temperature sensor). Select **N/A** (default) or **0 - 90** for Fahrenheit (**-18 - 31** for Celsius).

**NOTES:** Auxiliary Heat Balance Point:

- Must be at least 1° higher than the Heat Pump Balance Point.
- Cannot be accessed for Dual Fuel systems.

# User Controls

Select **User Controls** and then configure these settings:

The image displays five screenshots of the 'USER CONTROLS' menu, arranged in three rows. Each screenshot shows a different configuration step:

- Top Left:** '1/5' step. 'Auto Setpoint' is set to 'Dual'. 'Setpoint Units' is set to '1F'. 'Temp Display Offset' is set to '0.0'.
- Top Right:** '2/5' step. 'Heat' mode is selected. 'Lower Setpoint' is set to '38'. 'Upper Setpoint' is set to '89'.
- Middle Left:** '3/5' step. 'Cool' mode is selected. 'Lower Setpoint' is set to '59'. 'Upper Setpoint' is set to '99'.
- Middle Right:** '4/5' step. 'Auto' mode is selected. 'Lower Setpoint' is set to '59'. 'Upper Setpoint' is set to '99'.
- Bottom:** '5/5' step. 'Auto Deadband' is set to '2.0'.

## NOTES:

- In Heat Only and Cool Only systems, the **Auto Setpoint** option is not available.
- In Cool Only systems, the **Heat Lower Setpoint** and **Heat Upper Setpoint** options are not available.
- In Heat Only systems, the **Cool Lower Setpoint** and **Cool Upper Setpoint** options are not available.
- In Heat Only or Cool Only systems or when **Auto Setpoint** is set to **Dual** or **Disable**, the **Auto Lower Setpoint** and **Auto Upper Setpoint** options are not available.
- In Heat Only or Cool Only systems or when **Auto Setpoint** is set to **Disable**, the **Auto Deadband** option is not available.

- **Auto Setpoint:** Defines how Auto mode operates. Select **Dual** (default) to use individual heat and cool setpoints, **Single** to use one setpoint for both heat and cool, or **Disabled** to turn off Auto mode.
- **Setpoint Units:** Defines the temperature scale and setpoint incrementation for the thermostat and sensors. Select **1F** (default), **1C**, or **0.5C**.
- **Temp Display Offset:** Adjusts an offset between the space temperature displayed and the temperature sensed. Select **-6** to **+6** for Fahrenheit or **-3.0** - **+3.0** for Celsius. The default setting is **0**.
- **Heat Lower Setpoint:** Limits the minimum heat setpoint the end user can set. Select **38 - 79** (Fahrenheit) or **3 - 27** (Celsius). The default setting is 38 (Fahrenheit) or 3 (Celsius)
- **Heat Upper Setpoint:** Limits the maximum heat setpoint the end user can set. The **Upper Setpoint** must be at least 10° (Fahrenheit) or 5° (Celsius) higher than the **Lower Setpoint**. Select **48 - 89** for (Fahrenheit) or **8 - 32** (Celsius). The default setting is 89 (Fahrenheit) or 32 (Celsius)
- **Cool Lower Setpoint:** Limits the minimum cool setpoint the end user can set. Select **38 - 89** (Fahrenheit) or **3 - 32** (Celsius). The default setting is 59 (Fahrenheit) or 15 (Celsius).
- **Cool Upper Setpoint:** Limits the maximum cool setpoint the end user can set. The **Upper Setpoint** must be at least 10° (Fahrenheit) or 5° (Celsius) higher than the **Lower Setpoint**. Select **48 - 99** for (Fahrenheit) or **8 - 37** (Celsius). The default setting is 99 (Fahrenheit) or 37 (Celsius).
- **Auto Lower Setpoint:** Limits the minimum auto setpoint the end user can set. Select **38 - 89** (Fahrenheit) or **3 - 32** (Celsius). The default setting is 59 (Fahrenheit) or 15 (Celsius).
- **Auto Upper Setpoint:** Limits the maximum auto setpoint the end user can set. The **Upper Setpoint** must be at least 10° (Fahrenheit) or 5° (Celsius) higher than the **Lower Setpoint**. Select **48 - 99** for (Fahrenheit) or **8 - 37** (Celsius). The default setting is 99 (Fahrenheit) or 37 (Celsius).
- **Auto Deadband:** This sets the separation between the heat and cool setpoints in Auto mode. In Dual Mode, this is the minimum separation allowed. Select **2.0** (default), **3.0**, **4.0**, **5.0**, or **6.0** for Fahrenheit or **1.0** (default), **2.0**, or **3.0** for Celsius.

# Sensor Setup

Select **Sensor Setup** and then configure these settings:

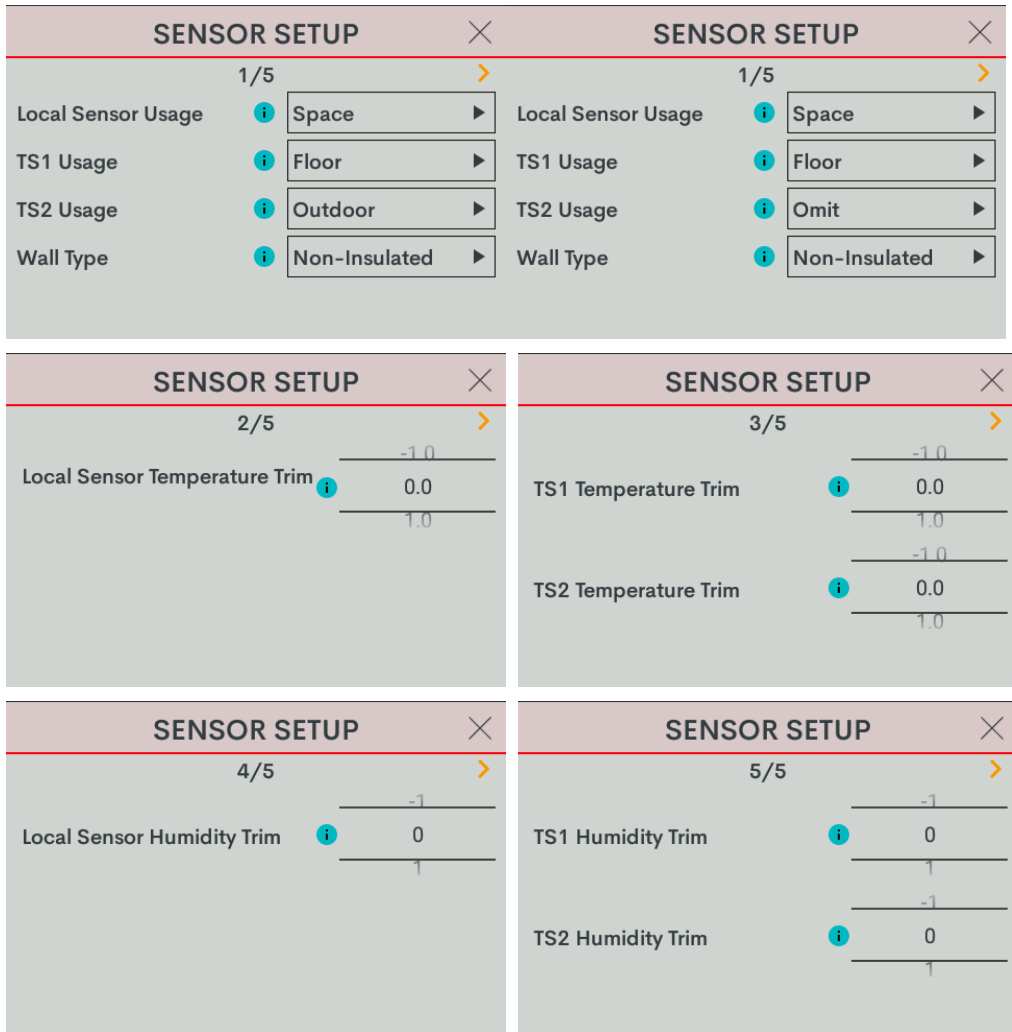

- **Local Sensor Usage:** Defines how the local sensor is used by the thermostat. Select **Omit** or **Space**.

- **Omit:** Omits channel from thermostat operation

**NOTE:** Sensor temperature and humidity can be output to the network even if Omit is selected.

- **Space:** Adds channel to space temperature/humidity average

- **TS1 Usage:** Defines how remote sensor channel 1 is used by the thermostat.
  - **Omit:** (Default) Omits channel from thermostat operation
  - **Space:** Adds channel to space temperature/humidity average
  - **Outdoor:** Adds channel to outdoor temperature/humidity average
  - **Floor:** Adds channel to slab (floor) temperature average
- **TS2 Usage:** Defines how remote sensor channel 2 is used by the thermostat.
  - **Omit:** (Default) Omits channel from thermostat operation
  - **Space:** Adds channel to space temperature/humidity average
  - **Outdoor:** Adds channel to outdoor temperature/humidity average
  - **Floor:** Adds channel to slab (floor) temperature average
- **Wall Type:** Defines the wall type that the thermostat is installed into for accurate temperature readings. Select **Non-Insulated** (hollow) or **Insulated**.
- **Local Sensor Temperature Trim:** Adjusts local sensor temperature measurement. Select **-6** to **+6** for Fahrenheit (**-3.0** to **+3.0** for Celsius). The default setting is **0**.
- **TS1 Temperature Trim:** Adjusts temperature sensed by temperature sensor(s) attached to TS1 input. Select **-6** to **+6** for Fahrenheit (**-3.0** to **+3.0** for Celsius). The default setting is **0**.
- **TS2 Temperature Trim:** Adjusts temperature sensed by temperature sensor(s) attached to TS2 input. Select **-6** to **+6** for Fahrenheit (**-3.0** to **+3.0** for Celsius). The default setting is **0**.
- **Local Sensor Humidity Trim:** Adjusts local sensor humidity percentage. Select **-9.0** to **+9.0**. The default setting is **0**.
- **TS1 Humidity Trim:** Adjusts humidity percentage sensed by temperature/humidity sensor attached to TS1 input. Select **-9.0** to **+9.0**. The default setting is **0**.
- **TS2 Humidity Trim:** Adjusts humidity percentage sensed by temperature/humidity sensor attached to TS2 input. Select **-9.0** to **+9.0**. The default setting is **0**.

## Humidistat Setup

Select **Humidistat Setup** and then configure these settings:

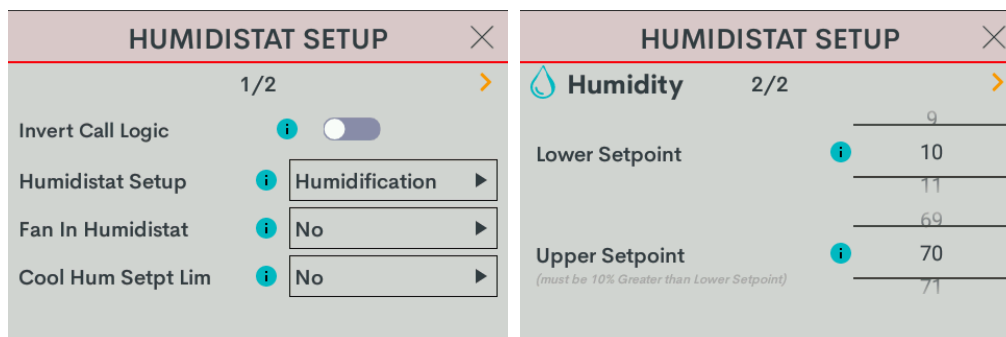

- **Invert Call Logic:** Change the HUM relay control logic for a humidifier or dehumidifier expecting a Normally Closed (NC) input. To invert the call logic, turn on the switch. The default setting is off for a Normally Open (NO) input.

- **Humidistat Setup:** Sets the operating mode of the HUM relay. Select **Humidification** (default), **Dehumidification**, or **Off**.
  - **Humidification:** Calls HUM relay when sensed humidity is below the humidistat setpoint.
  - **Dehumidification:** Calls HUM relay when sensed humidity is above the humidistat setpoint.
  - **Off:** Disable humidistat
- **Fan In Humidistat:** Select **No** (default) or **Yes**.

If **Yes**, the thermostat will make a fan call when a humidistat call is triggered instead of waiting for a heat or cool call to trigger the fan.
- **Cool Humidistat Setpoint Limit:** Limits internal humidistat setpoint to prevent window condensation when it is cold outside (displayed setpoint will not change). Select **No** (default) or **Yes**.
- **Lower Setpoint:** Limits the minimum humidistat setpoint percentage. Select **5 - 80**. The default setting is 10.
- **Upper Setpoint:** Limits the maximum humidistat setpoint percentage. Select **15 - 90**. The default setting is 70.

**NOTE:** The **Upper Setpoint** must be 10% higher than the **Lower Setpoint**.

# Radiant Floor Only (Floor Warming)

Go to **Settings > Installer Settings > System Configuration** to open the **SYSTEM CONFIGURATION** screen.

Use the **System Type**, **System Performance**, **Radiant Floor**, **User Controls**, **Humidistat Setup**, and **Sensor Setup** options to configure the thermostat to work with the connected HVAC system.

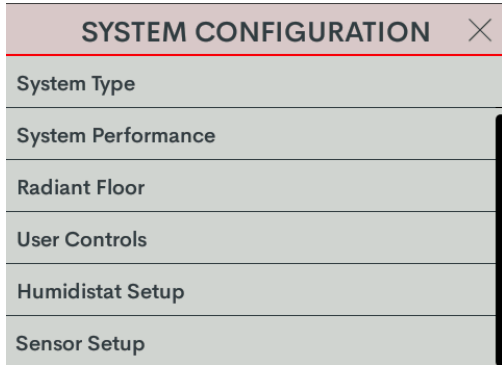

## Radiant Floor

Select **Radiant Floor** and then configure these settings:

**NOTE:** When setting **Radiant Floor** to **Space Heat** or **Floor Warm/Space Heat**, the Radiant Floor will be used as the first stage of heat and any Heat Stages setup under **SYSTEM TYPE** will be additional stages of heat.

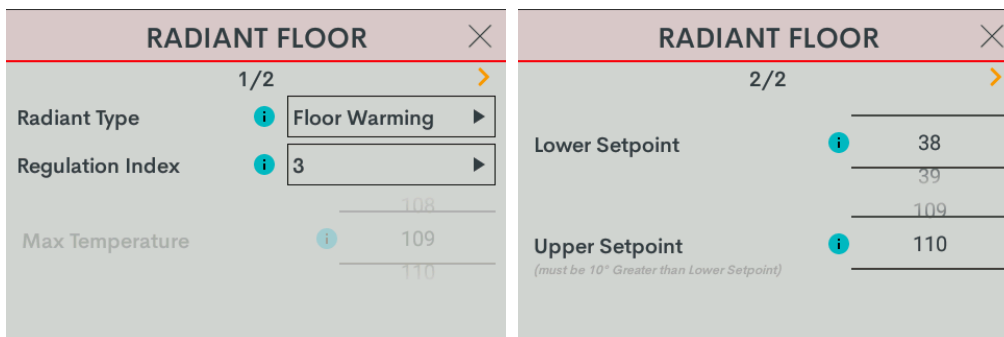

- **Radiant Type:** Select **Floor Warming**.
- **Regulation Index:** Select **1, 2, 3** (default), **4, 5**, or **6**.

For example, to adjust Floor Warming system cycling characteristics, select 1 for a narrow temperature regulation or 6 for a wide temperature regulation.

**NOTE:** The **Regulation Index** option is not available when Space Heating is selected.

- **Max Temperature:** Used to prevent the floor from becoming too hot during long heat calls. Select **50 - 110** (Fahrenheit) or **10 - 43** (Celsius). The default setting is **110** for Fahrenheit and **43** for Celsius.

**NOTE:** The **Max Temperature** option is not available when Floor Warming is selected.

- **Lower Setpoint:** Limits minimum floor warming setpoint. Select **38 - 100** for Fahrenheit (**3 - 38** for Celsius). Default setting: 38 for Fahrenheit (3 for Celsius).
- **Upper Setpoint:** Limits maximum floor warming setpoint. Select **48 - 110** for Fahrenheit (**8 - 43** for Celsius). Default setting: 110 for Fahrenheit (43 for Celsius).

**NOTE:** The **Upper Setpoint** must be 10° higher than the **Lower Setpoint**.

## System Type

Select **System Type** and then configure these settings:

The image shows two side-by-side screenshots of the 'SYSTEM TYPE' configuration interface. Each screen has a title bar with 'SYSTEM TYPE' and a close button (X). The left screen is labeled '1/2' and shows the following settings: System Type (None), Fan In Heat (No), Heat Stages (1), and Cool Stages (1). The right screen is labeled '2/2' and shows the following settings: Fan Speeds (Low, Med, High), Fan Speed Staging (No), Compressor Stages (1), and Aux Heat Stages (1). Each setting has an information icon (i) and a right-pointing arrow (▶).

**System Type:** Select **None**.

**NOTE:** When System Type is set to **None**, the following SYSTEM CONTROL settings cannot be accessed: Fan In Heat, Heat Stages, Cool Stages, Heat Pump Compressor Stages, and Heat Pump Auxiliary Stages.

# User Controls

Select **User Controls** and then configure these settings:

USER CONTROLS

1/5

Auto Setpoint Dual

Setpoint Units 1F

Temp Display Offset 0.0

- **Setpoint Units:** Defines the temperature scale and setpoint incrementation for the thermostat and sensors. Select **1F** (default), **1C**, or **0.5C**.
- **Temp Display Offset:** Adjusts an offset between the space temperature displayed and the temperature sensed. Select **-6** to **+6** for Fahrenheit or **-3.0** - **+3.0** for Celsius. The default setting is **0**.

**NOTE:** When System Type is set to **None**, the **Auto Setpoint**, **Heat Lower Setpoint**, **Heat Upper Setpoint**, **Cool Lower Setpoint**, **Cool Upper Setpoint**, **Auto Lower Setpoint**, **Auto Upper Setpoint**, and **Auto Deadband** options are not available.

# Sensor Setup

Select **Sensor Setup** and then configure these settings:

**NOTE:** Requires a slab remote sensor (CHV-RSS, sold separately).

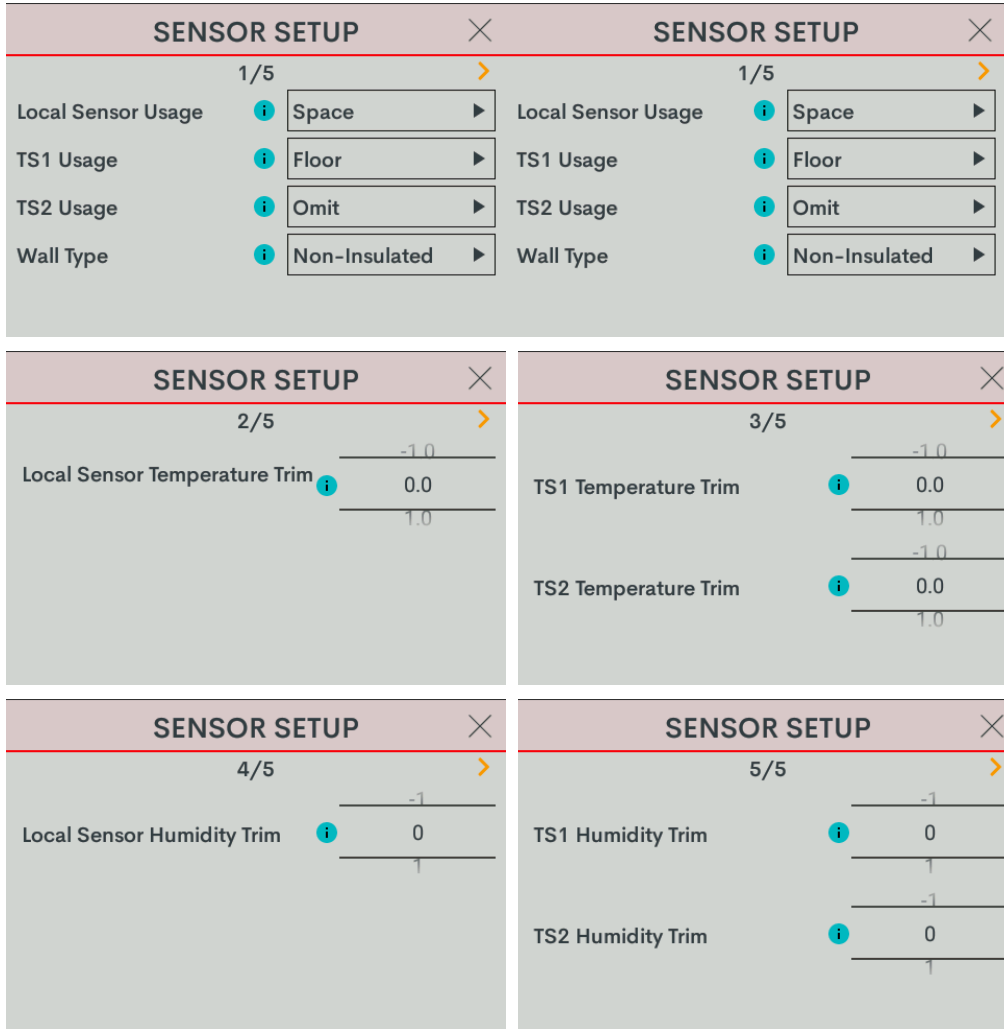

- **Local Sensor Usage:** Defines how the local sensor is used by the thermostat. Select **Omit** or **Space**.
  - **Omit:** Omits channel from thermostat operation

**NOTE:** Sensor temperature and humidity can be output to the network even if Omit is selected.

- **Space:** Adds channel to space temperature/humidity average

- **TS1 Usage:** Defines how remote sensor channel 1 is used by the thermostat.
  - **Omit:** (Default) Omits channel from thermostat operation
  - **Space:** Adds channel to space temperature/humidity average
  - **Outdoor:** Adds channel to outdoor temperature/humidity average
  - **Floor:** Adds channel to slab (floor) temperature average
- **TS2 Usage:** Defines how remote sensor channel 2 is used by the thermostat.
  - **Omit:** (Default) Omits channel from thermostat operation
  - **Space:** Adds channel to space temperature/humidity average
  - **Outdoor:** Adds channel to outdoor temperature/humidity average
  - **Floor:** Adds channel to slab (floor) temperature average
- **Wall Type:** Defines the wall type that the thermostat is installed into for accurate temperature readings. Select **Non-Insulated** (hollow) or **Insulated**.
- **Local Sensor Temperature Trim:** Adjusts local sensor temperature measurement. Select **-6** to **+6** for Fahrenheit (**-3.0** to **+3.0** for Celsius). The default setting is **0**.
- **TS1 Temperature Trim:** Adjusts temperature sensed by temperature sensor(s) attached to TS1 input. Select **-6** to **+6** for Fahrenheit (**-3.0** to **+3.0** for Celsius). The default setting is **0**.
- **TS2 Temperature Trim:** Adjusts temperature sensed by temperature sensor(s) attached to TS2 input. Select **-6** to **+6** for Fahrenheit (**-3.0** to **+3.0** for Celsius). The default setting is **0**.
- **Local Sensor Humidity Trim:** Adjusts local sensor humidity percentage. Select **-9.0** to **+9.0**. The default setting is **0**.
- **TS1 Humidity Trim:** Adjusts humidity percentage sensed by temperature/humidity sensor attached to TS1 input. Select **-9.0** to **+9.0**. The default setting is **0**.
- **TS2 Humidity Trim:** Adjusts humidity percentage sensed by temperature/humidity sensor attached to TS2 input. Select **-9.0** to **+9.0**. The default setting is **0**.

## Humidistat Setup

Select **Humidistat Setup** and then configure these settings:

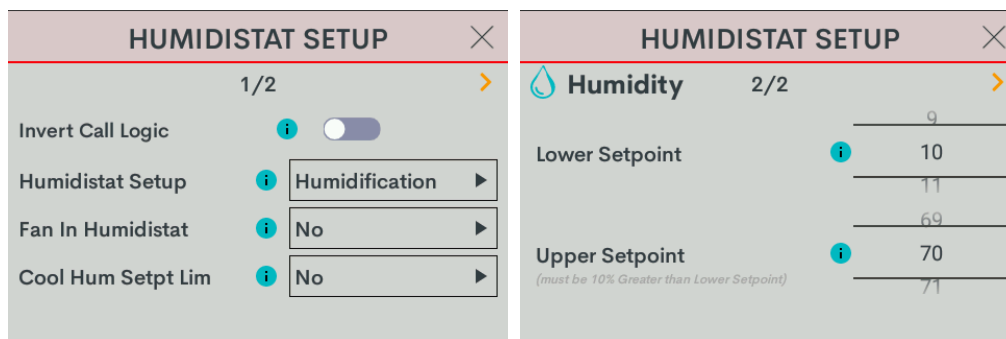

- **Invert Call Logic:** Change the HUM relay control logic for a humidifier or dehumidifier expecting a Normally Closed (NC) input. To invert the call logic, turn on the switch. The default setting is off for a Normally Open (NO) input.

- **Humidistat Setup:** Sets the operating mode of the HUM relay. Select **Humidification** (default), **Dehumidification**, or **Off**.
  - **Humidification:** Calls HUM relay when sensed humidity is below the humidistat setpoint.
  - **Dehumidification:** Calls HUM relay when sensed humidity is above the humidistat setpoint.
  - **Off:** Disable humidistat
- **Fan In Humidistat:** Select **No** (default) or **Yes**.

If **Yes**, the thermostat will make a fan call when a humidistat call is triggered instead of waiting for a heat or cool call to trigger the fan.
- **Cool Humidistat Setpoint Limit:** Limits internal humidistat setpoint to prevent window condensation when it is cold outside (displayed setpoint will not change). Select **No** (default) or **Yes**.
- **Lower Setpoint:** Limits the minimum humidistat setpoint percentage. Select **5 - 80**. The default setting is 10.
- **Upper Setpoint:** Limits the maximum humidistat setpoint percentage. Select **15 - 90**. The default setting is 70.

**NOTE:** The **Upper Setpoint** must be 10% higher than the **Lower Setpoint**.

# Radiant Floor Only (Space Heating)

Go to **Settings > Installer Settings > System Configuration** to open the **SYSTEM CONFIGURATION** screen.

Use the **System Type**, **System Performance**, **Radiant Floor**, **User Controls**, **Humidistat Setup**, and **Sensor Setup** options to configure the thermostat to work with the connected HVAC system.

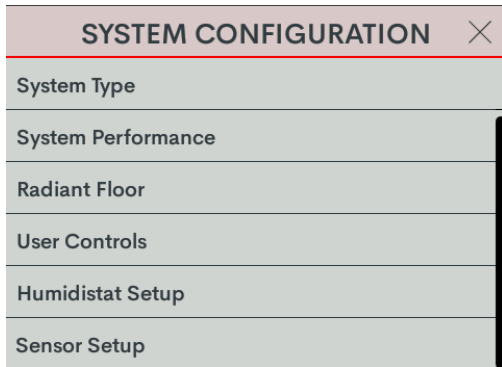

## Radiant Floor

Select **Radiant Floor** and then configure these settings:

**NOTE:** When setting **Radiant Floor** to **Space Heat** or **Floor Warm/Space Heat**, the Radiant Floor will be used as the first stage of heat and any Heat Stages setup under **SYSTEM TYPE** will be additional stages of heat.

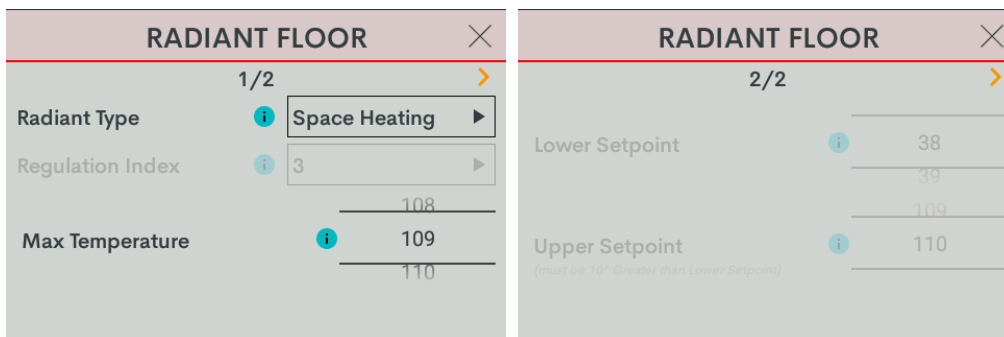

- **Radiant Type:** Select **Space Heating**.
- **Regulation Index:** Select **1, 2, 3** (default), **4, 5**, or **6**.

For example, to adjust Floor Warming system cycling characteristics, select 1 for a narrow temperature regulation or 6 for a wide temperature regulation.

**NOTE:** The **Regulation Index** option is not available when Space Heating is selected.

- **Max Temperature:** Used to prevent the floor from becoming too hot during long heat calls. Select **50 - 110** (Fahrenheit) or **10 - 43** (Celsius). The default setting is **110** for Fahrenheit and **43** for Celsius.

**NOTE:** The **Max Temperature** option is not available when Floor Warming is selected.

**NOTE:** These settings cannot be accessed for Space Heating.

## System Type

Select **System Type** and then configure these settings:

SYSTEM TYPE		×
1/2		>
System Type	<i>i</i> None	▶
Fan In Heat	<i>i</i> No	▶
Heat Stages	<i>i</i> 1	▶
Cool Stages	<i>i</i> 1	▶

SYSTEM TYPE		×
2/2		>
Fan Speeds	<i>i</i> Low, Med, High	▶
Fan Speed Staging	<i>i</i> No	▶
Compressor Stages	<i>i</i> 1	▶
Aux Heat Stages	<i>i</i> 1	▶

**System Type:** Select **None**.

**NOTE:** When System Type is set to **None**, the following SYSTEM CONTROL settings cannot be accessed: Fan In Heat, Heat Stages, Cool Stages, Heat Pump Compressor Stages, and Heat Pump Auxiliary Stages.

# User Controls

Select **User Controls** and then configure these settings:

USER CONTROLS

1/5

Auto Setpoint Dual

Setpoint Units 1F

Temp Display Offset 0.0

- **Setpoint Units:** Defines the temperature scale and setpoint incrementation for the thermostat and sensors. Select **1F** (default), **1C**, or **0.5C**.
- **Temp Display Offset:** Adjusts an offset between the space temperature displayed and the temperature sensed. Select **-6** to **+6** for Fahrenheit or **-3.0** - **+3.0** for Celsius. The default setting is **0**.

**NOTE:** When System Type is set to **None**, the **Auto Setpoint**, **Heat Lower Setpoint**, **Heat Upper Setpoint**, **Cool Lower Setpoint**, **Cool Upper Setpoint**, **Auto Lower Setpoint**, **Auto Upper Setpoint**, and **Auto Deadband** options are not available.

# Sensor Setup

Select **Sensor Setup** and then configure these settings:

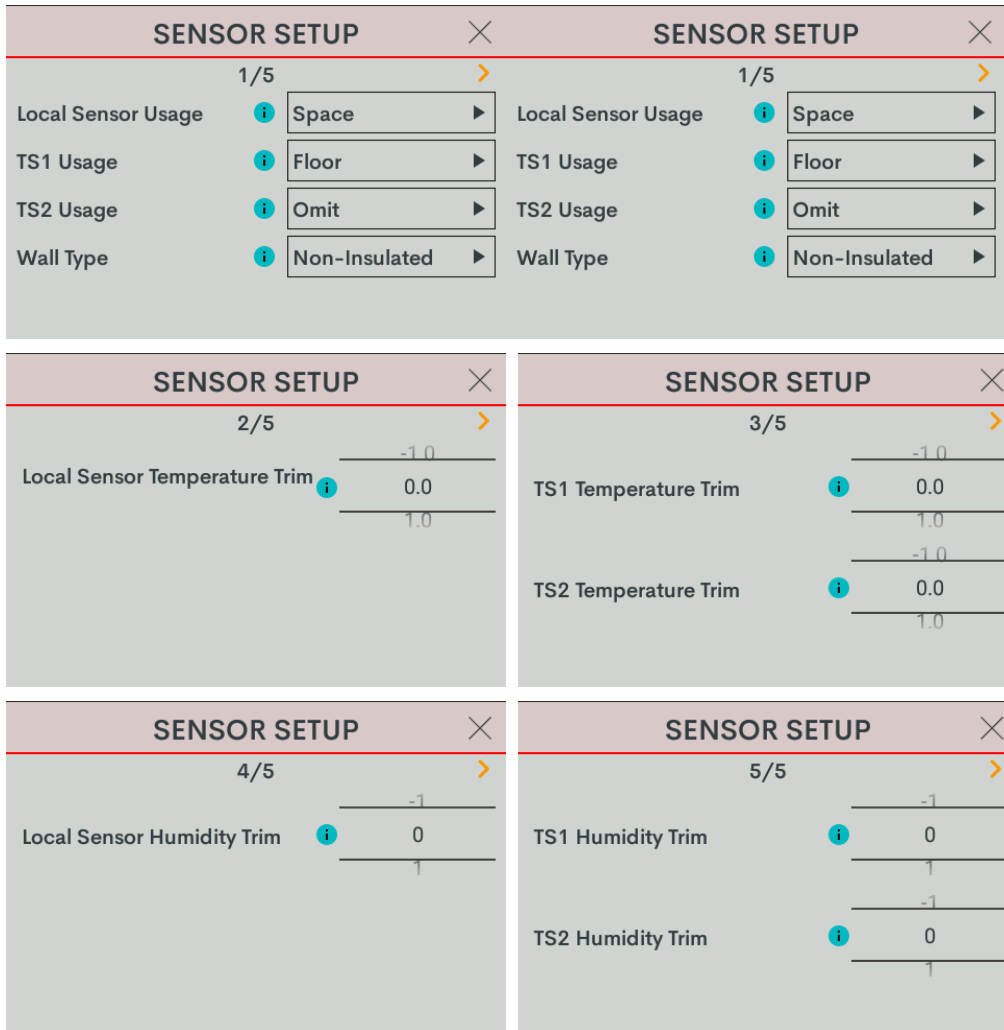

- **Local Sensor Usage:** Defines how the local sensor is used by the thermostat. Select **Omit** or **Space**.

- **Omit:** Omits channel from thermostat operation

**NOTE:** Sensor temperature and humidity can be output to the network even if Omit is selected.

- **Space:** Adds channel to space temperature/humidity average

- **TS1 Usage:** Defines how remote sensor channel 1 is used by the thermostat.
  - **Omit:** (Default) Omits channel from thermostat operation
  - **Space:** Adds channel to space temperature/humidity average
  - **Outdoor:** Adds channel to outdoor temperature/humidity average
  - **Floor:** Adds channel to slab (floor) temperature average
- **TS2 Usage:** Defines how remote sensor channel 2 is used by the thermostat.
  - **Omit:** (Default) Omits channel from thermostat operation
  - **Space:** Adds channel to space temperature/humidity average
  - **Outdoor:** Adds channel to outdoor temperature/humidity average
  - **Floor:** Adds channel to slab (floor) temperature average
- **Wall Type:** Defines the wall type that the thermostat is installed into for accurate temperature readings. Select **Non-Insulated** (hollow) or **Insulated**.
- **Local Sensor Temperature Trim:** Adjusts local sensor temperature measurement. Select **-6** to **+6** for Fahrenheit (**-3.0** to **+3.0** for Celsius). The default setting is **0**.
- **TS1 Temperature Trim:** Adjusts temperature sensed by temperature sensor(s) attached to TS1 input. Select **-6** to **+6** for Fahrenheit (**-3.0** to **+3.0** for Celsius). The default setting is **0**.
- **TS2 Temperature Trim:** Adjusts temperature sensed by temperature sensor(s) attached to TS2 input. Select **-6** to **+6** for Fahrenheit (**-3.0** to **+3.0** for Celsius). The default setting is **0**.
- **Local Sensor Humidity Trim:** Adjusts local sensor humidity percentage. Select **-9.0** to **+9.0**. The default setting is **0**.
- **TS1 Humidity Trim:** Adjusts humidity percentage sensed by temperature/humidity sensor attached to TS1 input. Select **-9.0** to **+9.0**. The default setting is **0**.
- **TS2 Humidity Trim:** Adjusts humidity percentage sensed by temperature/humidity sensor attached to TS2 input. Select **-9.0** to **+9.0**. The default setting is **0**.

## Humidistat Setup

Select **Humidistat Setup** and then configure these settings:

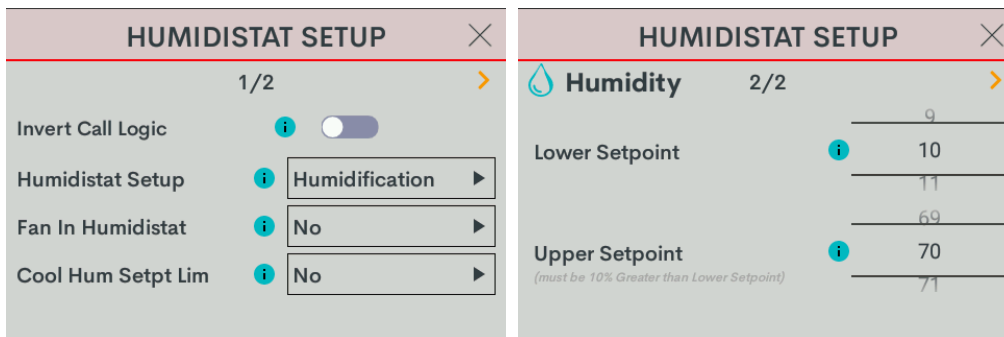

- **Invert Call Logic:** Change the HUM relay control logic for a humidifier or dehumidifier expecting a Normally Closed (NC) input. To invert the call logic, turn on the switch. The default setting is off for a Normally Open (NO) input.

- **Humidistat Setup:** Sets the operating mode of the HUM relay. Select **Humidification** (default), **Dehumidification**, or **Off**.
  - **Humidification:** Calls HUM relay when sensed humidity is below the humidistat setpoint.
  - **Dehumidification:** Calls HUM relay when sensed humidity is above the humidistat setpoint.
  - **Off:** Disable humidistat
- **Fan In Humidistat:** Select **No** (default) or **Yes**.

If **Yes**, the thermostat will make a fan call when a humidistat call is triggered instead of waiting for a heat or cool call to trigger the fan.
- **Cool Humidistat Setpoint Limit:** Limits internal humidistat setpoint to prevent window condensation when it is cold outside (displayed setpoint will not change). Select **No** (default) or **Yes**.
- **Lower Setpoint:** Limits the minimum humidistat setpoint percentage. Select **5 - 80**. The default setting is 10.
- **Upper Setpoint:** Limits the maximum humidistat setpoint percentage. Select **15 - 90**. The default setting is 70.

**NOTE:** The **Upper Setpoint** must be 10% higher than the **Lower Setpoint**.

# Radiant Floor Only (Floor Warming/Space Heating)

Go to **Settings > Installer Settings > System Configuration** to open the **SYSTEM CONFIGURATION** screen.

Use the **System Type**, **System Performance**, **Radiant Floor**, **User Controls**, **Humidistat Setup**, and **Sensor Setup** options to configure the thermostat to work with the connected HVAC system.

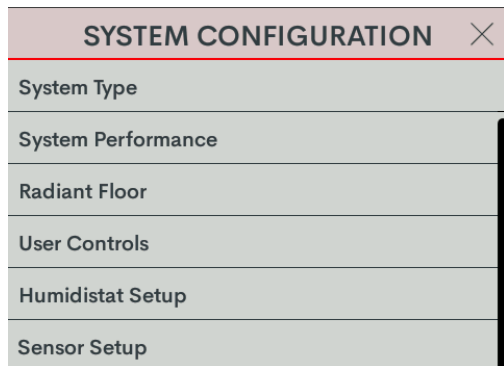

## Radiant Floor

Select **Radiant Floor** and then configure these settings:

**NOTE:** When setting **Radiant Floor** to **Space Heat** or **Floor Warm/Space Heat**, the Radiant Floor will be used as the first stage of heat and any Heat Stages setup under **SYSTEM TYPE** will be additional stages of heat.

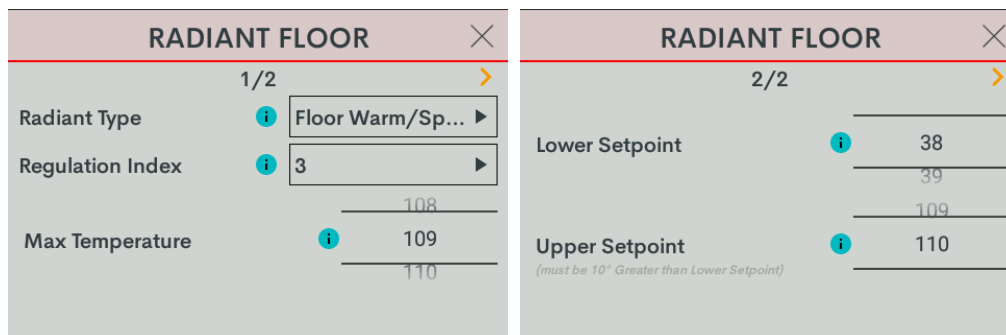

- **Radiant Type:** Select **Floor Warm/Space Heat**.

- **Regulation Index:** Select **1, 2, 3** (default), **4, 5**, or **6**.

For example, to adjust Floor Warming system cycling characteristics, select 1 for a narrow temperature regulation or 6 for a wide temperature regulation.

**NOTE:** The **Regulation Index** option is not available when Space Heating is selected.

- **Max Temperature:** Used to prevent the floor from becoming too hot during long heat calls. Select **50 - 110** (Fahrenheit) or **10 - 43** (Celsius). The default setting is **110** for Fahrenheit and **43** for Celsius.

**NOTE:** The **Max Temperature** option is not available when Floor Warming is selected.

- **Lower Setpoint:** Limits minimum floor warming setpoint. Select **38 - 100** for Fahrenheit (**3 - 38** for Celsius). Default setting: 38 for Fahrenheit (3 for Celsius).
- **Upper Setpoint:** Limits maximum floor warming setpoint. Select **48 - 110** for Fahrenheit (**8 - 43** for Celsius). Default setting: 110 for Fahrenheit (43 for Celsius).

**NOTE:** The **Upper Setpoint** must be 10° higher than the **Lower Setpoint**.

## System Type

Select **System Type** and then configure these settings:

The image shows two screenshots of the SYSTEM TYPE configuration interface. The first screenshot shows the 'SYSTEM TYPE' menu with 'None' selected. The second screenshot shows the 'SYSTEM TYPE' menu with 'None' selected and the 'SYSTEM CONTROL' settings menu open, showing 'Fan In Heat', 'Heat Stages', 'Cool Stages', 'Fan Speeds', 'Fan Speed Staging', 'Compressor Stages', and 'Aux Heat Stages'.

**System Type:** Select **None**

**NOTE:** When System Type is set to **None**, the following SYSTEM CONTROL settings cannot be accessed: Fan In Heat, Heat Stages, Cool Stages, Heat Pump Compressor Stages, and Heat Pump Auxiliary Stages.

# User Controls

Select **User Controls** and then configure these settings:

USER CONTROLS

1/5

Auto Setpoint Dual

Setpoint Units 1F

Temp Display Offset 0.0

- **Setpoint Units:** Defines the temperature scale and setpoint incrementation for the thermostat and sensors. Select **1F** (default), **1C**, or **0.5C**.
- **Temp Display Offset:** Adjusts an offset between the space temperature displayed and the temperature sensed. Select **-6** to **+6** for Fahrenheit or **-3.0** - **+3.0** for Celsius. The default setting is **0**.

**NOTE:** When System Type is set to **None**, the **Auto Setpoint**, **Heat Lower Setpoint**, **Heat Upper Setpoint**, **Cool Lower Setpoint**, **Cool Upper Setpoint**, **Auto Lower Setpoint**, **Auto Upper Setpoint**, and **Auto Deadband** options are not available.

# Sensor Setup

Select **Sensor Setup** and then configure these settings:

**NOTE:** Requires a slab remote sensor (CHV-RSS, sold separately).

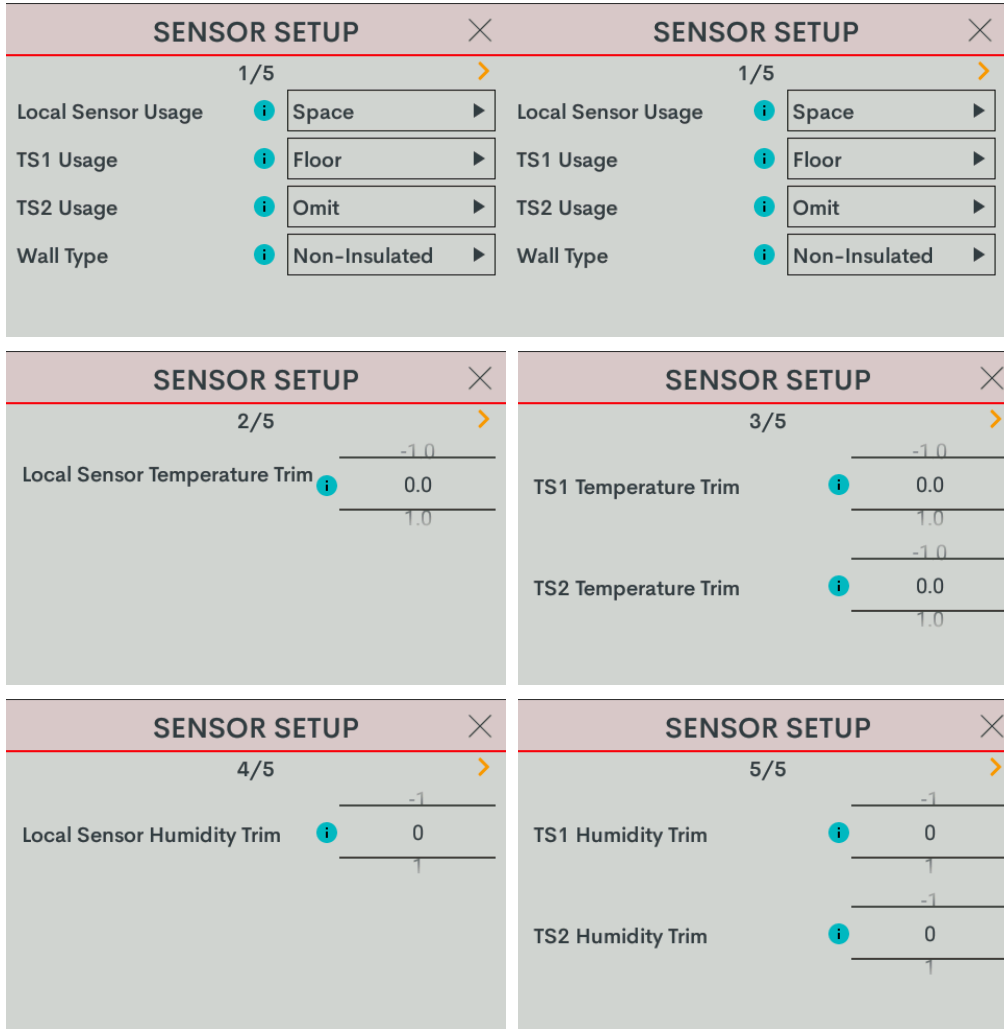

- **Local Sensor Usage:** Defines how the local sensor is used by the thermostat. Select **Omit** or **Space**.
  - **Omit:** Omits channel from thermostat operation

**NOTE:** Sensor temperature and humidity can be output to the network even if Omit is selected.

- **Space:** Adds channel to space temperature/humidity average

- **TS1 Usage:** Defines how remote sensor channel 1 is used by the thermostat.
  - **Omit:** (Default) Omits channel from thermostat operation
  - **Space:** Adds channel to space temperature/humidity average
  - **Outdoor:** Adds channel to outdoor temperature/humidity average
  - **Floor:** Adds channel to slab (floor) temperature average
- **TS2 Usage:** Defines how remote sensor channel 2 is used by the thermostat.
  - **Omit:** (Default) Omits channel from thermostat operation
  - **Space:** Adds channel to space temperature/humidity average
  - **Outdoor:** Adds channel to outdoor temperature/humidity average
  - **Floor:** Adds channel to slab (floor) temperature average
- **Wall Type:** Defines the wall type that the thermostat is installed into for accurate temperature readings. Select **Non-Insulated** (hollow) or **Insulated**.
- **Local Sensor Temperature Trim:** Adjusts local sensor temperature measurement. Select **-6** to **+6** for Fahrenheit (**-3.0** to **+3.0** for Celsius). The default setting is **0**.
- **TS1 Temperature Trim:** Adjusts temperature sensed by temperature sensor(s) attached to TS1 input. Select **-6** to **+6** for Fahrenheit (**-3.0** to **+3.0** for Celsius). The default setting is **0**.
- **TS2 Temperature Trim:** Adjusts temperature sensed by temperature sensor(s) attached to TS2 input. Select **-6** to **+6** for Fahrenheit (**-3.0** to **+3.0** for Celsius). The default setting is **0**.
- **Local Sensor Humidity Trim:** Adjusts local sensor humidity percentage. Select **-9.0** to **+9.0**. The default setting is **0**.
- **TS1 Humidity Trim:** Adjusts humidity percentage sensed by temperature/humidity sensor attached to TS1 input. Select **-9.0** to **+9.0**. The default setting is **0**.
- **TS2 Humidity Trim:** Adjusts humidity percentage sensed by temperature/humidity sensor attached to TS2 input. Select **-9.0** to **+9.0**. The default setting is **0**.

## Humidistat Setup

Select **Humidistat Setup** and then configure these settings:

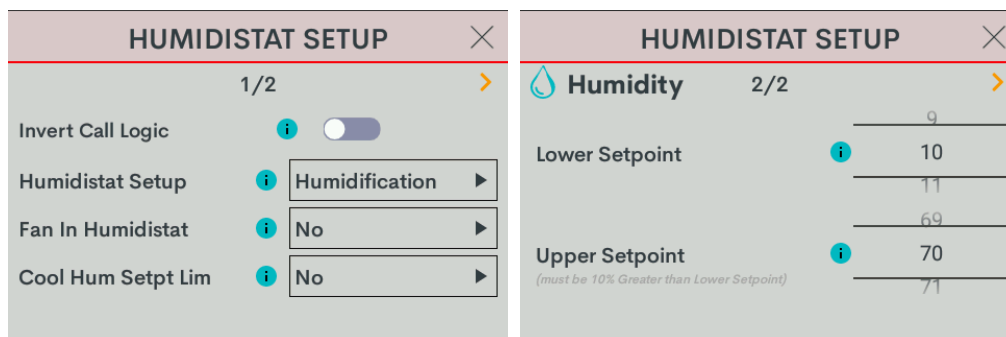

- **Invert Call Logic:** Change the HUM relay control logic for a humidifier or dehumidifier expecting a Normally Closed (NC) input. To invert the call logic, turn on the switch. The default setting is off for a Normally Open (NO) input.

- **Humidistat Setup:** Sets the operating mode of the HUM relay. Select **Humidification** (default), **Dehumidification**, or **Off**.
  - **Humidification:** Calls HUM relay when sensed humidity is below the humidistat setpoint.
  - **Dehumidification:** Calls HUM relay when sensed humidity is above the humidistat setpoint.
  - **Off:** Disable humidistat
- **Fan In Humidistat:** Select **No** (default) or **Yes**.

If **Yes**, the thermostat will make a fan call when a humidistat call is triggered instead of waiting for a heat or cool call to trigger the fan.
- **Cool Humidistat Setpoint Limit:** Limits internal humidistat setpoint to prevent window condensation when it is cold outside (displayed setpoint will not change). Select **No** (default) or **Yes**.
- **Lower Setpoint:** Limits the minimum humidistat setpoint percentage. Select **5 - 80**. The default setting is 10.
- **Upper Setpoint:** Limits the maximum humidistat setpoint percentage. Select **15 - 90**. The default setting is 70.

**NOTE:** The **Upper Setpoint** must be 10% higher than the **Lower Setpoint**.

# 2 Stage Heat (Stage 1 Radiant Floor)/1 Stage Cool

Go to **Settings > Installer Settings > System Configuration** to open the **SYSTEM CONFIGURATION** screen.

Use the **System Type, System Performance, Radiant Floor, User Controls, Humidistat Setup, and Sensor Setup** options to configure the thermostat to work with the connected HVAC system.

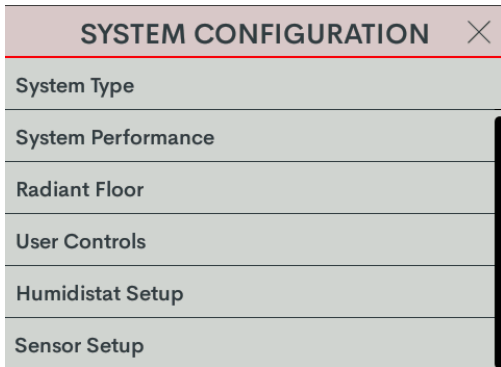

## Radiant Floor

Select **Radiant Floor** and then configure these settings:

**NOTE:** When setting **Radiant Floor** to **Space Heat** or **Floor Warm/Space Heat**, the Radiant Floor will be used as the first stage of heat and any Heat Stages setup under **SYSTEM TYPE** will be additional stages of heat.

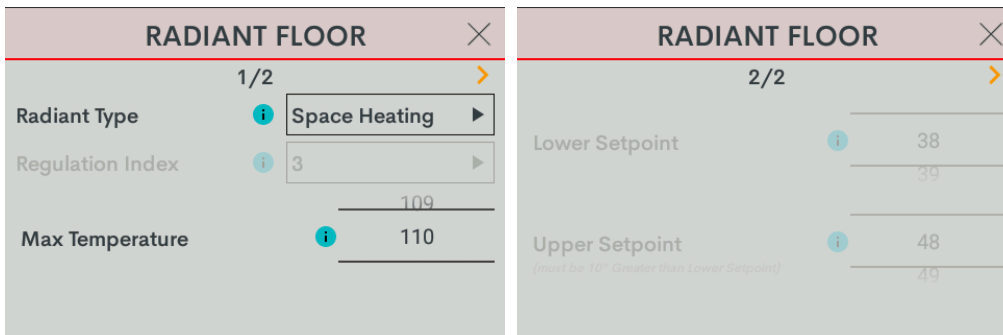

- **Radiant Type:** Select **Space Heat**

- **Regulation Index:** Select **1, 2, 3** (default), **4, 5**, or **6**.

For example, to adjust Floor Warming system cycling characteristics, select 1 for a narrow temperature regulation or 6 for a wide temperature regulation.

**NOTE:** The **Regulation Index** option is not available when Space Heating is selected.

- **Max Temperature:** Used to prevent the floor from becoming too hot during long heat calls. Select **50 - 110** (Fahrenheit) or **10 - 43** (Celsius). The default setting is **110** for Fahrenheit and **43** for Celsius.

**NOTE:** The **Max Temperature** option is not available when Floor Warming is selected.

**NOTE:** These settings cannot be accessed for Space Heating.

## System Type

Select **System Type** and then configure these settings:

The image shows two screenshots of the 'SYSTEM TYPE' configuration interface. The first screenshot shows the 'SYSTEM TYPE' screen with 'Heat/Cool' selected. The second screenshot shows the 'SYSTEM TYPE' screen with 'Fan In Heat' set to 'No', 'Heat Stages' set to '1', and 'Cool Stages' set to '1'.

- System Type: Select **Heat/Cool**

**NOTE:** There are Heat Only and Cool Only options for a Heat Only or Cool Only system type.

- **Fan In Heat:** Select **Yes** or **No** (default).
  - **Yes:** Fan called for second stage (W).
  - **No:** Disable fan call operation for heat calls.

**Heat Stages:** Number of heat-only stages present. Select **1**.

**Cool Stages:** Number of cool-only (air conditioning) stages present. Select **1**.

# System Performance

Select **System Performance** and then configure these settings:

The image displays three sequential screenshots of the 'SYSTEM PERFORMANCE' configuration interface. Each screenshot shows a different set of settings, indicated by a progress indicator (1/3, 2/3, 3/3) and a right-pointing arrow. Each setting includes an information icon (i) and a right-pointing arrow.

- Screenshot 1 (1/3):** Heat Anticipator (3), Cool Anticipator (3), Interstage Diff (2.0).
- Screenshot 2 (2/3):** Accum. Staging Index (3), H.Pump Balance Point (N/A).
- Screenshot 3 (3/3):** Short Cycle Timeout (180 sec.), Aux Heat Balance Point (N/A).

- **Heat Anticipator:** Select **1, 2, 3** (default), **4, 5**, or **6**.  
For example, to adjust space heating system cycling characteristics, select **1** for more frequent cycles and faster responses or **6** for less frequent cycles and slower responses.
- **Cool Anticipator:** Select **1, 2, 3** (default), **4, 5**, or **6**.  
For example, to adjust cooling system cycling characteristics, select **1** for more frequent cycles and faster responses or **6** for less frequent cycles and slower responses.
- **Interstage Differential:** The proportional temperature error to trigger the next stage. Select **0.5 - 8.0** for Fahrenheit or **0.2 - 4.5** for Celsius. The default setting is **2.0** for Fahrenheit and **1.0** for Celsius.

**Accumulated Staging Index:** Triggers the next stage to meet demand in instances where the previous stage cannot reach the Interstage Differential or achieve the desired setpoint. Select **1, 2, 3** (default), **4, 5**, or **6**.

For example, select **1** for a faster trigger to the next stage or **5** for a slower trigger to the next stage. Setting **6** disables this feature altogether.

**Short Cycle Timeout:** The minimum off time between system calls. Select **30 seconds, 60 seconds**, or **180 seconds** (default).

# User Controls

Select **User Controls** and then configure these settings:

The image displays five screenshots of the 'USER CONTROLS' menu in a thermostat interface. Each screenshot shows a different page of settings, indicated by a page number (1/5, 2/5, 3/5, 4/5, 5/5) and a right-pointing arrow. The settings are as follows:

- Page 1/5:** Auto Setpoint (Dual), Setpoint Units (1F), Temp Display Offset (0.0).
- Page 2/5 (Heat):** Lower Setpoint (38), Upper Setpoint (89).
- Page 3/5 (Cool):** Lower Setpoint (59), Upper Setpoint (99).
- Page 4/5 (Auto):** Lower Setpoint (59), Upper Setpoint (99).
- Page 5/5:** Auto Deadband (2.0).

## NOTES:

- In Heat Only and Cool Only systems, the **Auto Setpoint** option is not available.
- In Cool Only systems, the **Heat Lower Setpoint** and **Heat Upper Setpoint** options are not available.
- In Heat Only systems, the **Cool Lower Setpoint** and **Cool Upper Setpoint** options are not available.
- In Heat Only or Cool Only systems or when **Auto Setpoint** is set to **Dual** or **Disable**, the **Auto Lower Setpoint** and **Auto Upper Setpoint** options are not available.
- In Heat Only or Cool Only systems or when **Auto Setpoint** is set to **Disable**, the **Auto Deadband** option is not available.

- **Auto Setpoint:** Defines how Auto mode operates. Select **Dual** (default) to use individual heat and cool setpoints, **Single** to use one setpoint for both heat and cool, or **Disabled** to turn off Auto mode.
- **Setpoint Units:** Defines the temperature scale and setpoint incrementation for the thermostat and sensors. Select **1F** (default), **1C**, or **0.5C**.
- **Temp Display Offset:** Adjusts an offset between the space temperature displayed and the temperature sensed. Select **-6** to **+6** for Fahrenheit or **-3.0** - **+3.0** for Celsius. The default setting is **0**.
- **Heat Lower Setpoint:** Limits the minimum heat setpoint the end user can set. Select **38 - 79** (Fahrenheit) or **3 - 27** (Celsius). The default setting is 38 (Fahrenheit) or 3 (Celsius)
- **Heat Upper Setpoint:** Limits the maximum heat setpoint the end user can set. The **Upper Setpoint** must be at least 10° (Fahrenheit) or 5° (Celsius) higher than the **Lower Setpoint**. Select **48 - 89** for (Fahrenheit) or **8 - 32** (Celsius). The default setting is 89 (Fahrenheit) or 32 (Celsius)
- **Cool Lower Setpoint:** Limits the minimum cool setpoint the end user can set. Select **38 - 89** (Fahrenheit) or **3 - 32** (Celsius). The default setting is 59 (Fahrenheit) or 15 (Celsius).
- **Cool Upper Setpoint:** Limits the maximum cool setpoint the end user can set. The **Upper Setpoint** must be at least 10° (Fahrenheit) or 5° (Celsius) higher than the **Lower Setpoint**. Select **48 - 99** for (Fahrenheit) or **8 - 37** (Celsius). The default setting is 99 (Fahrenheit) or 37 (Celsius).
- **Auto Lower Setpoint:** Limits the minimum auto setpoint the end user can set. Select **38 - 89** (Fahrenheit) or **3 - 32** (Celsius). The default setting is 59 (Fahrenheit) or 15 (Celsius).
- **Auto Upper Setpoint:** Limits the maximum auto setpoint the end user can set. The **Upper Setpoint** must be at least 10° (Fahrenheit) or 5° (Celsius) higher than the **Lower Setpoint**. Select **48 - 99** for (Fahrenheit) or **8 - 37** (Celsius). The default setting is 99 (Fahrenheit) or 37 (Celsius).
- **Auto Deadband:** This sets the separation between the heat and cool setpoints in Auto mode. In Dual Mode, this is the minimum separation allowed. Select **2.0** (default), **3.0**, **4.0**, **5.0**, or **6.0** for Fahrenheit or **1.0** (default), **2.0**, or **3.0** for Celsius.

# Sensor Setup

Select **Sensor Setup** and then configure these settings:

**NOTE:** Requires a slab remote sensor (CHV-RSS, sold separately).

SENSOR SETUP		SENSOR SETUP	
1/5		1/5	
Local Sensor Usage	<input type="text" value="Space"/>	Local Sensor Usage	<input type="text" value="Space"/>
TS1 Usage	<input type="text" value="Floor"/>	TS1 Usage	<input type="text" value="Floor"/>
TS2 Usage	<input type="text" value="Outdoor"/>	TS2 Usage	<input type="text" value="Omit"/>
Wall Type	<input type="text" value="Non-Insulated"/>	Wall Type	<input type="text" value="Non-Insulated"/>

SENSOR SETUP	
1/5	
Local Sensor Usage	<input type="text" value="Space"/>
TS1 Usage	<input type="text" value="Floor"/>
TS2 Usage	<input type="text" value="Omit"/>
Wall Type	<input type="text" value="Non-Insulated"/>

SENSOR SETUP	
2/5	
Local Sensor Temperature Trim	<input type="text" value="0.0"/>

SENSOR SETUP	
3/5	
TS1 Temperature Trim	<input type="text" value="0.0"/>
TS2 Temperature Trim	<input type="text" value="0.0"/>

SENSOR SETUP	
4/5	
Local Sensor Humidity Trim	<input type="text" value="0"/>

SENSOR SETUP	
5/5	
TS1 Humidity Trim	<input type="text" value="0"/>
TS2 Humidity Trim	<input type="text" value="0"/>

- **Local Sensor Usage:** Defines how the local sensor is used by the thermostat. Select **Omit** or **Space**.

- **Omit:** Omits channel from thermostat operation

**NOTE:** Sensor temperature and humidity can be output to the network even if Omit is selected.

- **Space:** Adds channel to space temperature/humidity average

- **TS1 Usage:** Defines how remote sensor channel 1 is used by the thermostat.
  - **Omit:** (Default) Omits channel from thermostat operation
  - **Space:** Adds channel to space temperature/humidity average
  - **Outdoor:** Adds channel to outdoor temperature/humidity average
  - **Floor:** Adds channel to slab (floor) temperature average
- **TS2 Usage:** Defines how remote sensor channel 2 is used by the thermostat.
  - **Omit:** (Default) Omits channel from thermostat operation
  - **Space:** Adds channel to space temperature/humidity average
  - **Outdoor:** Adds channel to outdoor temperature/humidity average
  - **Floor:** Adds channel to slab (floor) temperature average
- **Wall Type:** Defines the wall type that the thermostat is installed into for accurate temperature readings. Select **Non-Insulated** (hollow) or **Insulated**.
- **Local Sensor Temperature Trim:** Adjusts local sensor temperature measurement. Select **-6** to **+6** for Fahrenheit (**-3.0** to **+3.0** for Celsius). The default setting is **0**.
- **TS1 Temperature Trim:** Adjusts temperature sensed by temperature sensor(s) attached to TS1 input. Select **-6** to **+6** for Fahrenheit (**-3.0** to **+3.0** for Celsius). The default setting is **0**.
- **TS2 Temperature Trim:** Adjusts temperature sensed by temperature sensor(s) attached to TS2 input. Select **-6** to **+6** for Fahrenheit (**-3.0** to **+3.0** for Celsius). The default setting is **0**.
- **Local Sensor Humidity Trim:** Adjusts local sensor humidity percentage. Select **-9.0** to **+9.0**. The default setting is **0**.
- **TS1 Humidity Trim:** Adjusts humidity percentage sensed by temperature/humidity sensor attached to TS1 input. Select **-9.0** to **+9.0**. The default setting is **0**.
- **TS2 Humidity Trim:** Adjusts humidity percentage sensed by temperature/humidity sensor attached to TS2 input. Select **-9.0** to **+9.0**. The default setting is **0**.

## Humidstat Setup

Select **Humidstat Setup** and then configure these settings:

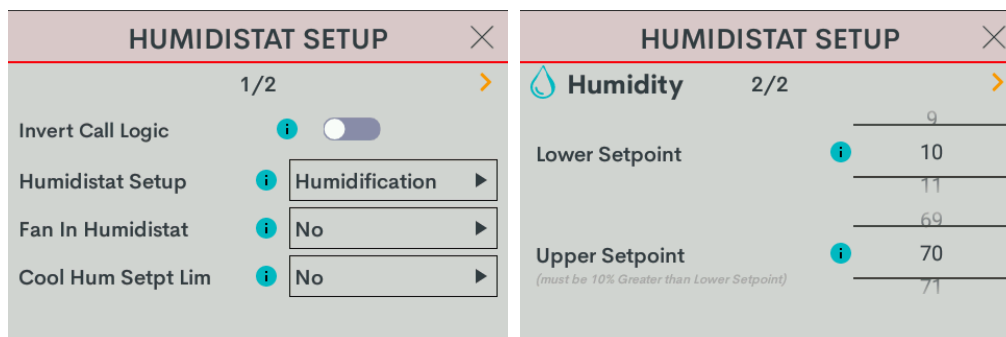

- **Invert Call Logic:** Change the HUM relay control logic for a humidifier or dehumidifier expecting a Normally Closed (NC) input. To invert the call logic, turn on the switch. The default setting is off for a Normally Open (NO) input.

- **Humidistat Setup:** Sets the operating mode of the HUM relay. Select **Humidification** (default), **Dehumidification**, or **Off**.
  - **Humidification:** Calls HUM relay when sensed humidity is below the humidistat setpoint.
  - **Dehumidification:** Calls HUM relay when sensed humidity is above the humidistat setpoint.
  - **Off:** Disable humidistat
- **Fan In Humidistat:** Select **No** (default) or **Yes**.

If **Yes**, the thermostat will make a fan call when a humidistat call is triggered instead of waiting for a heat or cool call to trigger the fan.
- **Cool Humidistat Setpoint Limit:** Limits internal humidistat setpoint to prevent window condensation when it is cold outside (displayed setpoint will not change). Select **No** (default) or **Yes**.
- **Lower Setpoint:** Limits the minimum humidistat setpoint percentage. Select **5 - 80**. The default setting is 10.
- **Upper Setpoint:** Limits the maximum humidistat setpoint percentage. Select **15 - 90**. The default setting is 70.

**NOTE:** The **Upper Setpoint** must be 10% higher than the **Lower Setpoint**.

# 2 Stage Heat (Stage 1 Radiant Floor)/1 Stage Cool Heat Pump with 1 Stage Aux Heat

Go to **Settings > Installer Settings > System Configuration** to open the **SYSTEM CONFIGURATION** screen.

Use the **System Type**, **System Performance**, **Radiant Floor**, **User Controls**, **Humidistat Setup**, and **Sensor Setup** options to configure the thermostat to work with the connected HVAC system.

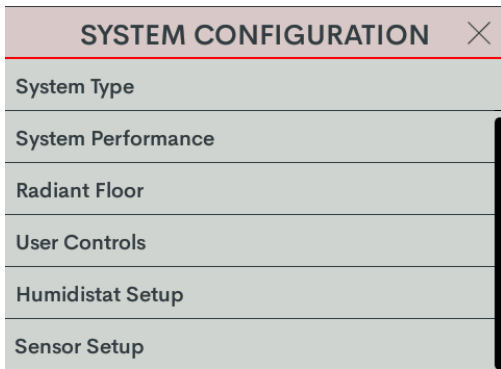

## Radiant Floor

Select **Radiant Floor** and then configure these settings:

**NOTE:** When setting **Radiant Floor** to **Space Heat** or **Floor Warm/Space Heat**, the Radiant Floor will be used as the first stage of heat and any Heat Stages setup under **SYSTEM TYPE** will be additional stages of heat.

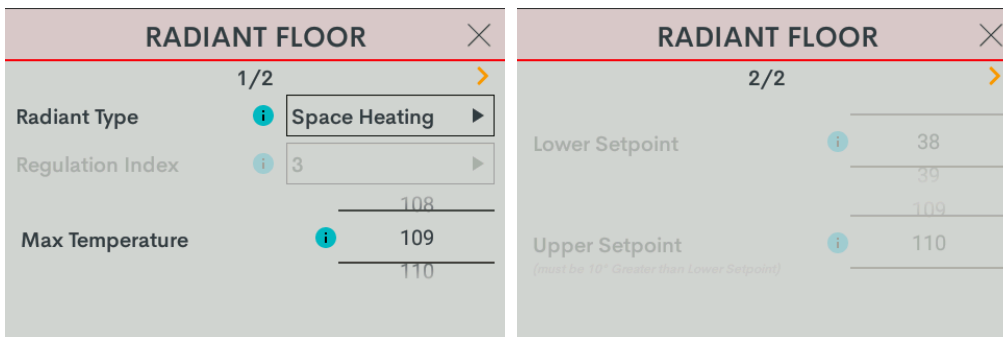

- **Radiant Type:** Select **Space Heating**.

- **Regulation Index:** Select **1, 2, 3** (default), **4, 5**, or **6**.

For example, to adjust Floor Warming system cycling characteristics, select 1 for a narrow temperature regulation or 6 for a wide temperature regulation.

**NOTE:** The **Regulation Index** option is not available when Space Heating is selected.

- **Max Temperature:** Used to prevent the floor from becoming too hot during long heat calls. Select **50 - 110** (Fahrenheit) or **10 - 43** (Celsius). The default setting is **110** for Fahrenheit and **43** for Celsius.

**NOTE:** The **Max Temperature** option is not available when Floor Warming is selected.

**NOTE:** These settings cannot be accessed for Space Heating.

## System Type

Select **System Type** and then configure these settings:

The image shows two screenshots of the 'SYSTEM TYPE' configuration interface. The first screenshot shows the 'SYSTEM TYPE' screen with settings for System Type (Heatpump w/...), Fan In Heat (No), Heat Stages (1), and Cool Stages (1). The second screenshot shows the 'SYSTEM TYPE' screen with settings for Fan Speeds (Low, Med, High), Fan Speed Staging (No), Compressor Stages (1), and Aux Heat Stages (1).

- **System Type:** Select **Heatpump w/ Aux**
- **Fan In Heat:** Select **Yes** or **No** (default).
  - **Yes:** Fan called for second stage (W).
  - **No:** Disable fan call operation for heat calls.

**NOTE:** With Radiant Floor set to Space heat, the Heat Pump Compressor Stages does not need to be set.

- **Heat Pump Compressor Stages:** Number of heat pump compressor stages present. Choose **1**.
- **Heat Pump Auxiliary Stages:** Number of Auxiliary Heat stages present. Choose **1**.

# System Performance

Select **System Performance** and then configure these settings:

The image displays three sequential screenshots of the 'SYSTEM PERFORMANCE' configuration window. Each window has a title bar with 'SYSTEM PERFORMANCE' and a close button (X). The first window, labeled '1/3', shows three settings: 'Heat Anticipator' with a value of 3, 'Cool Anticipator' with a value of 3, and 'Interstage Diff' with a value of 2.0. The second window, labeled '2/3', shows 'Accum. Staging Index' with a value of 3 and 'H.Pump Balance Point' with a value of N/A. The third window, labeled '3/3', shows 'Short Cycle Timeout' with a value of 180 sec. and 'Aux Heat Balance Point' with a value of N/A. Each setting includes an information icon (i) and a right-pointing arrow.

- **Heat Anticipator:** Select **1, 2, 3** (default), **4, 5**, or **6**.  
For example, to adjust space heating system cycling characteristics, select **1** for more frequent cycles and faster responses or **6** for less frequent cycles and slower responses.
- **Cool Anticipator:** Select **1, 2, 3** (default), **4, 5**, or **6**.  
For example, to adjust cooling system cycling characteristics, select **1** for more frequent cycles and faster responses or **6** for less frequent cycles and slower responses.
- **Interstage Differential:** The proportional temperature error to trigger the next stage. Select **0.5 - 8.0** for Fahrenheit or **0.2 - 4.5** for Celsius. The default setting is **2.0** for Fahrenheit and **1.0** for Celsius.
- **Accumulated Staging Index:** Triggers the next stage to meet demand in instances where the previous stage cannot reach the Interstage Differential or achieve the desired setpoint. Select **1, 2, 3** (default), **4, 5**, or **6**.  
For example, select **1** for a faster trigger to the next stage or **5** for a slower trigger to the next stage. Setting **6** disables this feature altogether.
- **Heat Pump Balance Point:** Minimum outdoor temperature at which the heat pump runs (requires an outdoor temperature source). Select **N/A** or **0 - 90** for Fahrenheit (**-18 - 31** for Celsius). Default setting: **N/A**.
- **Short Cycle Timeout:** The minimum off time between system calls. Select **30 seconds, 60 seconds, or 180 seconds** (default).

- **Auxiliary Heat Balance Point:** Maximum outdoor temperature at which Auxiliary heat system supplements the heat pump (requires an outdoor temperature sensor). Select **N/A** (default) or **0 - 90** for Fahrenheit (**-18 - 31** for Celsius).

**NOTES:** Auxiliary Heat Balance Point:

- Must be at least 1° higher than the Heat Pump Balance Point.
- Cannot be accessed for Dual Fuel systems.

# User Controls

Select **User Controls** and then configure these settings:

The image displays five screenshots of the 'USER CONTROLS' menu, arranged in three rows. Each screenshot shows a different configuration step:

- Top Left:** '1/5' step. 'Auto Setpoint' is set to 'Dual'. 'Setpoint Units' is set to '1F'. 'Temp Display Offset' is set to '0.0'.
- Top Right:** '2/5' step. 'Heat' mode is selected. 'Lower Setpoint' is 38, 'Upper Setpoint' is 89. A note states: '(must be 10° Greater than Lower Setpoint)'. Intermediate values 39 and 88 are shown.
- Middle Left:** '3/5' step. 'Cool' mode is selected. 'Lower Setpoint' is 59, 'Upper Setpoint' is 99. A note states: '(must be 10° Greater than Lower Setpoint)'. Intermediate values 58, 60, and 98 are shown.
- Middle Right:** '4/5' step. 'Auto' mode is selected. 'Lower Setpoint' is 59, 'Upper Setpoint' is 99. A note states: '(must be 10° Greater than Lower Setpoint)'. Intermediate values 58, 60, and 98 are shown.
- Bottom:** '5/5' step. 'Auto Deadband' is set to '2.0'. Intermediate values 3.0 are shown.

## NOTES:

- In Heat Only and Cool Only systems, the **Auto Setpoint** option is not available.
- In Cool Only systems, the **Heat Lower Setpoint** and **Heat Upper Setpoint** options are not available.
- In Heat Only systems, the **Cool Lower Setpoint** and **Cool Upper Setpoint** options are not available.
- In Heat Only or Cool Only systems or when **Auto Setpoint** is set to **Dual** or **Disable**, the **Auto Lower Setpoint** and **Auto Upper Setpoint** options are not available.
- In Heat Only or Cool Only systems or when **Auto Setpoint** is set to **Disable**, the **Auto Deadband** option is not available.

- **Auto Setpoint:** Defines how Auto mode operates. Select **Dual** (default) to use individual heat and cool setpoints, **Single** to use one setpoint for both heat and cool, or **Disabled** to turn off Auto mode.
- **Setpoint Units:** Defines the temperature scale and setpoint incrementation for the thermostat and sensors. Select **1F** (default), **1C**, or **0.5C**.
- **Temp Display Offset:** Adjusts an offset between the space temperature displayed and the temperature sensed. Select **-6** to **+6** for Fahrenheit or **-3.0** - **+3.0** for Celsius. The default setting is **0**.
- **Heat Lower Setpoint:** Limits the minimum heat setpoint the end user can set. Select **38 - 79** (Fahrenheit) or **3 - 27** (Celsius). The default setting is 38 (Fahrenheit) or 3 (Celsius)
- **Heat Upper Setpoint:** Limits the maximum heat setpoint the end user can set. The **Upper Setpoint** must be at least 10° (Fahrenheit) or 5° (Celsius) higher than the **Lower Setpoint**. Select **48 - 89** for (Fahrenheit) or **8 - 32** (Celsius). The default setting is 89 (Fahrenheit) or 32 (Celsius)
- **Cool Lower Setpoint:** Limits the minimum cool setpoint the end user can set. Select **38 - 89** (Fahrenheit) or **3 - 32** (Celsius). The default setting is 59 (Fahrenheit) or 15 (Celsius).
- **Cool Upper Setpoint:** Limits the maximum cool setpoint the end user can set. The **Upper Setpoint** must be at least 10° (Fahrenheit) or 5° (Celsius) higher than the **Lower Setpoint**. Select **48 - 99** for (Fahrenheit) or **8 - 37** (Celsius). The default setting is 99 (Fahrenheit) or 37 (Celsius).
- **Auto Lower Setpoint:** Limits the minimum auto setpoint the end user can set. Select **38 - 89** (Fahrenheit) or **3 - 32** (Celsius). The default setting is 59 (Fahrenheit) or 15 (Celsius).
- **Auto Upper Setpoint:** Limits the maximum auto setpoint the end user can set. The **Upper Setpoint** must be at least 10° (Fahrenheit) or 5° (Celsius) higher than the **Lower Setpoint**. Select **48 - 99** for (Fahrenheit) or **8 - 37** (Celsius). The default setting is 99 (Fahrenheit) or 37 (Celsius).
- **Auto Deadband:** This sets the separation between the heat and cool setpoints in Auto mode. In Dual Mode, this is the minimum separation allowed. Select **2.0** (default), **3.0**, **4.0**, **5.0**, or **6.0** for Fahrenheit or **1.0** (default), **2.0**, or **3.0** for Celsius.

# Sensor Setup

Select **Sensor Setup** and then configure these settings:

**NOTE:** Requires a slab remote sensor (CHV-RSS, sold separately).

SENSOR SETUP		SENSOR SETUP	
1/5		1/5	
Local Sensor Usage	<input type="text" value="Space"/>	Local Sensor Usage	<input type="text" value="Space"/>
TS1 Usage	<input type="text" value="Floor"/>	TS1 Usage	<input type="text" value="Floor"/>
TS2 Usage	<input type="text" value="Outdoor"/>	TS2 Usage	<input type="text" value="Omit"/>
Wall Type	<input type="text" value="Non-Insulated"/>	Wall Type	<input type="text" value="Non-Insulated"/>

SENSOR SETUP	
1/5	
Local Sensor Usage	<input type="text" value="Space"/>
TS1 Usage	<input type="text" value="Floor"/>
TS2 Usage	<input type="text" value="Omit"/>
Wall Type	<input type="text" value="Non-Insulated"/>

SENSOR SETUP	
2/5	
Local Sensor Temperature Trim	<input type="text" value="0.0"/>

SENSOR SETUP	
3/5	
TS1 Temperature Trim	<input type="text" value="0.0"/>
TS2 Temperature Trim	<input type="text" value="0.0"/>

SENSOR SETUP	
4/5	
Local Sensor Humidity Trim	<input type="text" value="0"/>

SENSOR SETUP	
5/5	
TS1 Humidity Trim	<input type="text" value="0"/>
TS2 Humidity Trim	<input type="text" value="0"/>

- **Local Sensor Usage:** Defines how the local sensor is used by the thermostat. Select **Omit** or **Space**.

- **Omit:** Omits channel from thermostat operation

**NOTE:** Sensor temperature and humidity can be output to the network even if Omit is selected.

- **Space:** Adds channel to space temperature/humidity average

- **TS1 Usage:** Defines how remote sensor channel 1 is used by the thermostat.
  - **Omit:** (Default) Omits channel from thermostat operation
  - **Space:** Adds channel to space temperature/humidity average
  - **Outdoor:** Adds channel to outdoor temperature/humidity average
  - **Floor:** Adds channel to slab (floor) temperature average
- **TS2 Usage:** Defines how remote sensor channel 2 is used by the thermostat.
  - **Omit:** (Default) Omits channel from thermostat operation
  - **Space:** Adds channel to space temperature/humidity average
  - **Outdoor:** Adds channel to outdoor temperature/humidity average
  - **Floor:** Adds channel to slab (floor) temperature average
- **Wall Type:** Defines the wall type that the thermostat is installed into for accurate temperature readings. Select **Non-Insulated** (hollow) or **Insulated**.
- **Local Sensor Temperature Trim:** Adjusts local sensor temperature measurement. Select **-6** to **+6** for Fahrenheit (**-3.0** to **+3.0** for Celsius). The default setting is **0**.
- **TS1 Temperature Trim:** Adjusts temperature sensed by temperature sensor(s) attached to TS1 input. Select **-6** to **+6** for Fahrenheit (**-3.0** to **+3.0** for Celsius). The default setting is **0**.
- **TS2 Temperature Trim:** Adjusts temperature sensed by temperature sensor(s) attached to TS2 input. Select **-6** to **+6** for Fahrenheit (**-3.0** to **+3.0** for Celsius). The default setting is **0**.
- **Local Sensor Humidity Trim:** Adjusts local sensor humidity percentage. Select **-9.0** to **+9.0**. The default setting is **0**.
- **TS1 Humidity Trim:** Adjusts humidity percentage sensed by temperature/humidity sensor attached to TS1 input. Select **-9.0** to **+9.0**. The default setting is **0**.
- **TS2 Humidity Trim:** Adjusts humidity percentage sensed by temperature/humidity sensor attached to TS2 input. Select **-9.0** to **+9.0**. The default setting is **0**.

## Humidistat Setup

Select **Humidistat Setup** and then configure these settings:

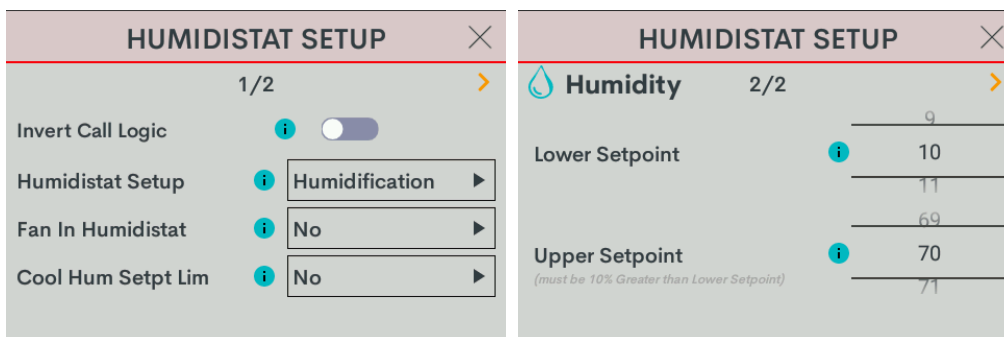

- **Invert Call Logic:** Change the HUM relay control logic for a humidifier or dehumidifier expecting a Normally Closed (NC) input. To invert the call logic, turn on the switch. The default setting is off for a Normally Open (NO) input.

- **Humidistat Setup:** Sets the operating mode of the HUM relay. Select **Humidification** (default), **Dehumidification**, or **Off**.
  - **Humidification:** Calls HUM relay when sensed humidity is below the humidistat setpoint.
  - **Dehumidification:** Calls HUM relay when sensed humidity is above the humidistat setpoint.
  - **Off:** Disable humidistat
- **Fan In Humidistat:** Select **No** (default) or **Yes**.

If **Yes**, the thermostat will make a fan call when a humidistat call is triggered instead of waiting for a heat or cool call to trigger the fan.
- **Cool Humidistat Setpoint Limit:** Limits internal humidistat setpoint to prevent window condensation when it is cold outside (displayed setpoint will not change). Select **No** (default) or **Yes**.
- **Lower Setpoint:** Limits the minimum humidistat setpoint percentage. Select **5 - 80**. The default setting is 10.
- **Upper Setpoint:** Limits the maximum humidistat setpoint percentage. Select **15 - 90**. The default setting is 70.

**NOTE:** The **Upper Setpoint** must be 10% higher than the **Lower Setpoint**.

# 2 Stage Heat (Stage 1 Radiant Floor Warming/Space Heating)/1 Stage Cool

Go to **Settings > Installer Settings > System Configuration** to open the **SYSTEM CONFIGURATION** screen.

Use the **System Type**, **System Performance**, **Radiant Floor**, **User Controls**, **Humidistat Setup**, and **Sensor Setup** options to configure the thermostat to work with the connected HVAC system.

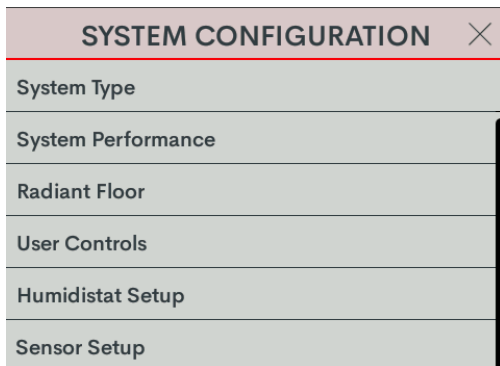

## Radiant Floor

Select **Radiant Floor** and then configure these settings:

**NOTE:** When setting **Radiant Floor** to **Space Heat** or **Floor Warm/Space Heat**, the Radiant Floor will be used as the first stage of heat and any Heat Stages setup under **SYSTEM TYPE** will be additional stages of heat.

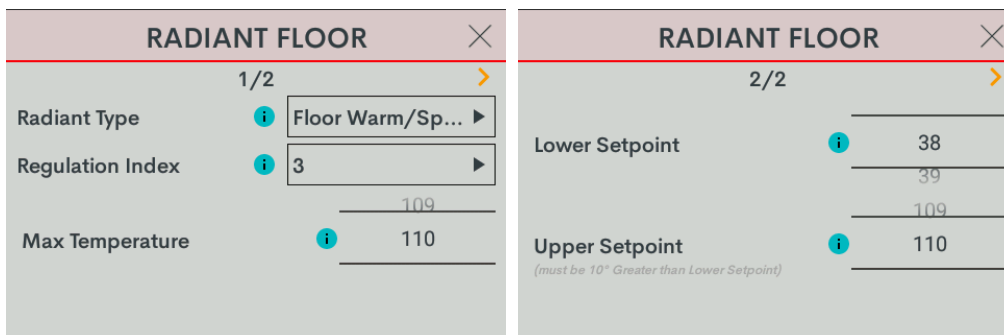

- **Radiant Type:** Select **Floor Warm/Space Heat**.

- **Regulation Index:** Select **1, 2, 3** (default), **4, 5**, or **6**.

For example, to adjust Floor Warming system cycling characteristics, select 1 for a narrow temperature regulation or 6 for a wide temperature regulation.

**NOTE:** The **Regulation Index** option is not available when Space Heating is selected.

- **Max Temperature:** Used to prevent the floor from becoming too hot during long heat calls. Select **50 - 110** (Fahrenheit) or **10 - 43** (Celsius). The default setting is **110** for Fahrenheit and **43** for Celsius.

**NOTE:** The **Max Temperature** option is not available when Floor Warming is selected.

- **Lower Setpoint:** Limits minimum floor warming setpoint. Select **38 - 100** for Fahrenheit (**3 - 38** for Celsius). Default setting: 38 for Fahrenheit (3 for Celsius).
- **Upper Setpoint:** Limits maximum floor warming setpoint. Select **48 - 110** for Fahrenheit (**8 - 43** for Celsius). Default setting: 110 for Fahrenheit (43 for Celsius).

**NOTE:** The **Upper Setpoint** must be 10° higher than the **Lower Setpoint**.

## System Type

Select **System Type** and then configure these settings:

- **System Type:** Select **Heat/Cool**.

**NOTE:** There are Heat Only and Cool Only options for a Heat Only or Cool Only system type.

- **Fan In Heat:** Select **Yes** or **No** (default).
  - **Yes:** Fan called for second stage (W).
  - **No:** Disable fan call operation for heat calls.
- **Heat Stages:** Number of heat-only stages present. Select **1**.

**Cool Stages:** Number of cool-only (air conditioning) stages present. Select **1**.

# System Performance

Select **System Performance** and then configure these settings:

The image displays three sequential screenshots of the 'SYSTEM PERFORMANCE' configuration window. Each window has a title bar with 'SYSTEM PERFORMANCE' and a close button (X). The first window, labeled '1/3', shows three settings: 'Heat Anticipator' with a value of 3, 'Cool Anticipator' with a value of 3, and 'Interstage Diff' with a value of 2.0. The second window, labeled '2/3', shows 'Accum. Staging Index' with a value of 3 and 'H.Pump Balance Point' with a value of N/A. The third window, labeled '3/3', shows 'Short Cycle Timeout' with a value of 180 sec. and 'Aux Heat Balance Point' with a value of N/A. Each setting includes an information icon (i) and a right-pointing arrow.

- **Heat Anticipator:** Select **1, 2, 3** (default), **4, 5**, or **6**.  
For example, to adjust space heating system cycling characteristics, select **1** for more frequent cycles and faster responses or **6** for less frequent cycles and slower responses.
- **Cool Anticipator:** Select **1, 2, 3** (default), **4, 5**, or **6**.  
For example, to adjust cooling system cycling characteristics, select **1** for more frequent cycles and faster responses or **6** for less frequent cycles and slower responses.
- **Interstage Differential:** The proportional temperature error to trigger the next stage. Select **0.5 - 8.0** for Fahrenheit or **0.2 - 4.5** for Celsius. The default setting is **2.0** for Fahrenheit and **1.0** for Celsius.
- **Accumulated Staging Index:** Triggers the next stage to meet demand in instances where the previous stage cannot reach the Interstage Differential or achieve the desired setpoint. Select **1, 2, 3** (default), **4, 5**, or **6**.  
For example, select **1** for a faster trigger to the next stage or **5** for a slower trigger to the next stage. Setting **6** disables this feature altogether.
- **Short Cycle Timeout:** The minimum off time between system calls. Select **30 seconds, 60 seconds, or 180 seconds** (default).

# User Controls

Select **User Controls** and then configure these settings:

The image displays five screenshots of the 'USER CONTROLS' menu, arranged in three rows. Each screenshot shows a different configuration step:

- Screenshot 1 (Top Left):** Shows the '1/5' step. 'Auto Setpoint' is set to 'Dual', 'Setpoint Units' to '1F', and 'Temp Display Offset' to '0.0'.
- Screenshot 2 (Top Right):** Shows the '2/5' step for 'Heat'. 'Lower Setpoint' is 38 and 'Upper Setpoint' is 89. A note states '(must be 10° Greater than Lower Setpoint)'.
- Screenshot 3 (Middle Left):** Shows the '3/5' step for 'Cool'. 'Lower Setpoint' is 59 and 'Upper Setpoint' is 99. A note states '(must be 10° Greater than Lower Setpoint)'.
- Screenshot 4 (Middle Right):** Shows the '4/5' step for 'Auto'. 'Lower Setpoint' is 59 and 'Upper Setpoint' is 99. A note states '(must be 10° Greater than Lower Setpoint)'.
- Screenshot 5 (Bottom):** Shows the '5/5' step for 'Auto Deadband' set to '2.0'.

## NOTES:

- In Heat Only and Cool Only systems, the **Auto Setpoint** option is not available.
- In Cool Only systems, the **Heat Lower Setpoint** and **Heat Upper Setpoint** options are not available.
- In Heat Only systems, the **Cool Lower Setpoint** and **Cool Upper Setpoint** options are not available.
- In Heat Only or Cool Only systems or when **Auto Setpoint** is set to **Dual** or **Disable**, the **Auto Lower Setpoint** and **Auto Upper Setpoint** options are not available.
- In Heat Only or Cool Only systems or when **Auto Setpoint** is set to **Disable**, the **Auto Deadband** option is not available.

- **Auto Setpoint:** Defines how Auto mode operates. Select **Dual** (default) to use individual heat and cool setpoints, **Single** to use one setpoint for both heat and cool, or **Disabled** to turn off Auto mode.
- **Setpoint Units:** Defines the temperature scale and setpoint incrementation for the thermostat and sensors. Select **1F** (default), **1C**, or **0.5C**.
- **Temp Display Offset:** Adjusts an offset between the space temperature displayed and the temperature sensed. Select **-6** to **+6** for Fahrenheit or **-3.0** - **+3.0** for Celsius. The default setting is **0**.
- **Heat Lower Setpoint:** Limits the minimum heat setpoint the end user can set. Select **38 - 79** (Fahrenheit) or **3 - 27** (Celsius). The default setting is 38 (Fahrenheit) or 3 (Celsius)
- **Heat Upper Setpoint:** Limits the maximum heat setpoint the end user can set. The **Upper Setpoint** must be at least 10° (Fahrenheit) or 5° (Celsius) higher than the **Lower Setpoint**. Select **48 - 89** for (Fahrenheit) or **8 - 32** (Celsius). The default setting is 89 (Fahrenheit) or 32 (Celsius)
- **Cool Lower Setpoint:** Limits the minimum cool setpoint the end user can set. Select **38 - 89** (Fahrenheit) or **3 - 32** (Celsius). The default setting is 59 (Fahrenheit) or 15 (Celsius).
- **Cool Upper Setpoint:** Limits the maximum cool setpoint the end user can set. The **Upper Setpoint** must be at least 10° (Fahrenheit) or 5° (Celsius) higher than the **Lower Setpoint**. Select **48 - 99** for (Fahrenheit) or **8 - 37** (Celsius). The default setting is 99 (Fahrenheit) or 37 (Celsius).
- **Auto Lower Setpoint:** Limits the minimum auto setpoint the end user can set. Select **38 - 89** (Fahrenheit) or **3 - 32** (Celsius). The default setting is 59 (Fahrenheit) or 15 (Celsius).
- **Auto Upper Setpoint:** Limits the maximum auto setpoint the end user can set. The **Upper Setpoint** must be at least 10° (Fahrenheit) or 5° (Celsius) higher than the **Lower Setpoint**. Select **48 - 99** for (Fahrenheit) or **8 - 37** (Celsius). The default setting is 99 (Fahrenheit) or 37 (Celsius).
- **Auto Deadband:** This sets the separation between the heat and cool setpoints in Auto mode. In Dual Mode, this is the minimum separation allowed. Select **2.0** (default), **3.0**, **4.0**, **5.0**, or **6.0** for Fahrenheit or **1.0** (default), **2.0**, or **3.0** for Celsius.

# Sensor Setup

Select **Sensor Setup** and then configure these settings:

**NOTE:** Requires a slab remote sensor (CHV-RSS, sold separately).

SENSOR SETUP		SENSOR SETUP	
1/5		1/5	
Local Sensor Usage	<i>i</i> Space	Local Sensor Usage	<i>i</i> Space
TS1 Usage	<i>i</i> Floor	TS1 Usage	<i>i</i> Floor
TS2 Usage	<i>i</i> Outdoor	TS2 Usage	<i>i</i> Omit
Wall Type	<i>i</i> Non-Insulated	Wall Type	<i>i</i> Non-Insulated

SENSOR SETUP	
1/5	
Local Sensor Usage	<i>i</i> Space
TS1 Usage	<i>i</i> Floor
TS2 Usage	<i>i</i> Omit
Wall Type	<i>i</i> Non-Insulated

SENSOR SETUP	
2/5	
Local Sensor Temperature Trim	<i>i</i> $\frac{-1.0}{0.0}{1.0}$

SENSOR SETUP	
3/5	
TS1 Temperature Trim	<i>i</i> $\frac{-1.0}{0.0}{1.0}$
TS2 Temperature Trim	<i>i</i> $\frac{-1.0}{0.0}{1.0}$

SENSOR SETUP	
4/5	
Local Sensor Humidity Trim	<i>i</i> $\frac{-1}{0}{1}$

SENSOR SETUP	
5/5	
TS1 Humidity Trim	<i>i</i> $\frac{-1}{0}{1}$
TS2 Humidity Trim	<i>i</i> $\frac{-1}{0}{1}$

- **Local Sensor Usage:** Defines how the local sensor is used by the thermostat. Select **Omit** or **Space**.

- **Omit:** Omits channel from thermostat operation

**NOTE:** Sensor temperature and humidity can be output to the network even if Omit is selected.

- **Space:** Adds channel to space temperature/humidity average

- **TS1 Usage:** Defines how remote sensor channel 1 is used by the thermostat.
  - **Omit:** (Default) Omits channel from thermostat operation
  - **Space:** Adds channel to space temperature/humidity average
  - **Outdoor:** Adds channel to outdoor temperature/humidity average
  - **Floor:** Adds channel to slab (floor) temperature average
- **TS2 Usage:** Defines how remote sensor channel 2 is used by the thermostat.
  - **Omit:** (Default) Omits channel from thermostat operation
  - **Space:** Adds channel to space temperature/humidity average
  - **Outdoor:** Adds channel to outdoor temperature/humidity average
  - **Floor:** Adds channel to slab (floor) temperature average
- **Wall Type:** Defines the wall type that the thermostat is installed into for accurate temperature readings. Select **Non-Insulated** (hollow) or **Insulated**.
- **Local Sensor Temperature Trim:** Adjusts local sensor temperature measurement. Select **-6** to **+6** for Fahrenheit (**-3.0** to **+3.0** for Celsius). The default setting is **0**.
- **TS1 Temperature Trim:** Adjusts temperature sensed by temperature sensor(s) attached to TS1 input. Select **-6** to **+6** for Fahrenheit (**-3.0** to **+3.0** for Celsius). The default setting is **0**.
- **TS2 Temperature Trim:** Adjusts temperature sensed by temperature sensor(s) attached to TS2 input. Select **-6** to **+6** for Fahrenheit (**-3.0** to **+3.0** for Celsius). The default setting is **0**.
- **Local Sensor Humidity Trim:** Adjusts local sensor humidity percentage. Select **-9.0** to **+9.0**. The default setting is **0**.
- **TS1 Humidity Trim:** Adjusts humidity percentage sensed by temperature/humidity sensor attached to TS1 input. Select **-9.0** to **+9.0**. The default setting is **0**.
- **TS2 Humidity Trim:** Adjusts humidity percentage sensed by temperature/humidity sensor attached to TS2 input. Select **-9.0** to **+9.0**. The default setting is **0**.

## Humidistat Setup

Select **Humidistat Setup** and then configure these settings:

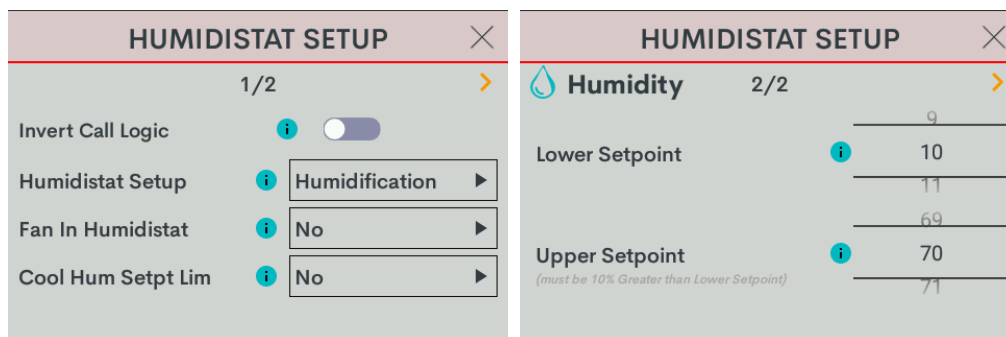

- **Invert Call Logic:** Change the HUM relay control logic for a humidifier or dehumidifier expecting a Normally Closed (NC) input. To invert the call logic, turn on the switch. The default setting is off for a Normally Open (NO) input.

- **Humidistat Setup:** Sets the operating mode of the HUM relay. Select **Humidification** (default), **Dehumidification**, or **Off**.
  - **Humidification:** Calls HUM relay when sensed humidity is below the humidistat setpoint.
  - **Dehumidification:** Calls HUM relay when sensed humidity is above the humidistat setpoint.
  - **Off:** Disable humidistat
- **Fan In Humidistat:** Select **No** (default) or **Yes**.

If **Yes**, the thermostat will make a fan call when a humidistat call is triggered instead of waiting for a heat or cool call to trigger the fan.
- **Cool Humidistat Setpoint Limit:** Limits internal humidistat setpoint to prevent window condensation when it is cold outside (displayed setpoint will not change). Select **No** (default) or **Yes**.
- **Lower Setpoint:** Limits the minimum humidistat setpoint percentage. Select **5 - 80**. The default setting is 10.
- **Upper Setpoint:** Limits the maximum humidistat setpoint percentage. Select **15 - 90**. The default setting is 70.

**NOTE:** The **Upper Setpoint** must be 10% higher than the **Lower Setpoint**.

# 2 Stage Heat (Stage 1 Radiant Floor Warming/Space Heating)/1 Stage Cool Heat Pump with 1 Stage Aux Heat

Go to **Settings > Installer Settings > System Configuration** to open the **SYSTEM CONFIGURATION** screen.

Use the **System Type**, **System Performance**, **Radiant Floor**, **User Controls**, **Humidistat Setup**, and **Sensor Setup** options to configure the thermostat to work with the connected HVAC system.

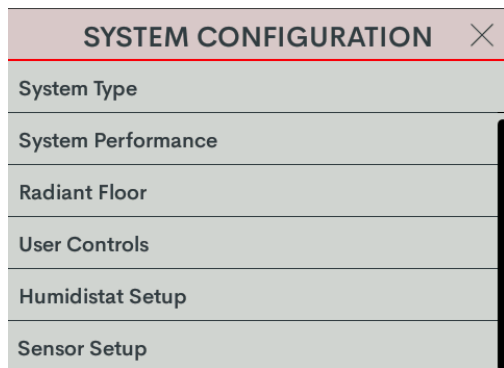

## Radiant Floor

Select **Radiant Floor** and then configure these settings:

**NOTE:** When setting **Radiant Floor** to **Space Heat** or **Floor Warm/Space Heat**, the Radiant Floor will be used as the first stage of heat and any Heat Stages setup under **SYSTEM TYPE** will be additional stages of heat.

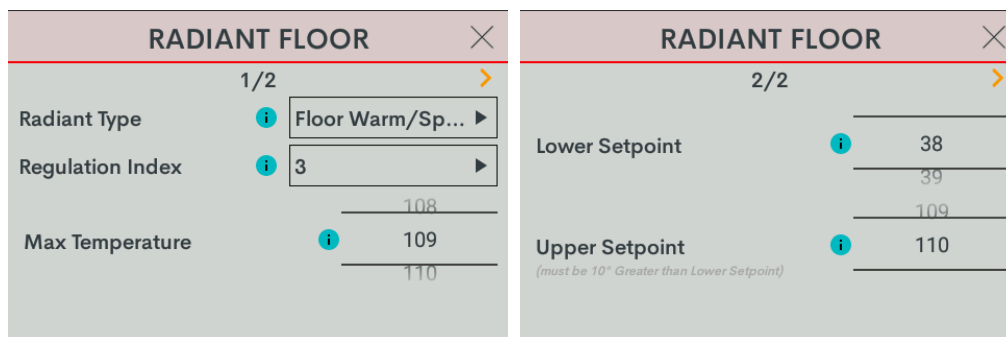

- **Radiant Type:** Select **Floor Warm/Space Heat**.

- **Regulation Index:** Select **1, 2, 3** (default), **4, 5**, or **6**.

For example, to adjust Floor Warming system cycling characteristics, select 1 for a narrow temperature regulation or 6 for a wide temperature regulation.

**NOTE:** The **Regulation Index** option is not available when Space Heating is selected.

- **Max Temperature:** Used to prevent the floor from becoming too hot during long heat calls. Select **50 - 110** (Fahrenheit) or **10 - 43** (Celsius). The default setting is **110** for Fahrenheit and **43** for Celsius.

**NOTE:** The **Max Temperature** option is not available when Floor Warming is selected.

- **Lower Setpoint:** Limits minimum floor warming setpoint. Select **38 - 100** for Fahrenheit (**3 - 38** for Celsius). Default setting: 38 for Fahrenheit (3 for Celsius).
- **Upper Setpoint:** Limits maximum floor warming setpoint. Select **48 - 110** for Fahrenheit (**8 - 43** for Celsius). Default setting: 110 for Fahrenheit (43 for Celsius).

**NOTE:** The **Upper Setpoint** must be 10° higher than the **Lower Setpoint**.

## System Type

Select **System Type** and then configure these settings:

- **System Type:** Select **Heatpump w/ Aux**.
- **Fan In Heat:** Select **Yes** or **No** (default).
  - **Yes:** Fan called for second stage (W).
  - **No:** Disable fan call operation for heat calls.

**NOTE:** With Radiant Floor set to Space heat, the Heat Pump Compressor Stages does not need to be set.

- **Heat Pump Compressor Stages:** Number of heat pump compressor stages present. Choose **1**.
- **Heat Pump Auxiliary Stages:** Number of Auxiliary Heat stages present. Choose **1**.

# System Performance

Select **System Performance** and then configure these settings:

The image displays three sequential screenshots of the 'SYSTEM PERFORMANCE' configuration interface. Each screenshot shows a different set of settings with a progress indicator at the top right.

- Screenshot 1 (1/3):** Shows 'Heat Anticipator' set to 3, 'Cool Anticipator' set to 3, and 'Interstage Diff' set to 2.0.
- Screenshot 2 (2/3):** Shows 'Accum. Staging Index' set to 3 and 'H.Pump Balance Point' set to N/A.
- Screenshot 3 (3/3):** Shows 'Short Cycle Timeout' set to 180 sec. and 'Aux Heat Balance Point' set to N/A.

- **Heat Anticipator:** Select **1, 2, 3** (default), **4, 5**, or **6**.  
For example, to adjust space heating system cycling characteristics, select **1** for more frequent cycles and faster responses or **6** for less frequent cycles and slower responses.
- **Cool Anticipator:** Select **1, 2, 3** (default), **4, 5**, or **6**.  
For example, to adjust cooling system cycling characteristics, select **1** for more frequent cycles and faster responses or **6** for less frequent cycles and slower responses.
- **Interstage Differential:** The proportional temperature error to trigger the next stage. Select **0.5 - 8.0** for Fahrenheit or **0.2 - 4.5** for Celsius. The default setting is **2.0** for Fahrenheit and **1.0** for Celsius.
- **Accumulated Staging Index:** Triggers the next stage to meet demand in instances where the previous stage cannot reach the Interstage Differential or achieve the desired setpoint. Select **1, 2, 3** (default), **4, 5**, or **6**.  
For example, select **1** for a faster trigger to the next stage or **5** for a slower trigger to the next stage. Setting **6** disables this feature altogether.
- **Heat Pump Balance Point:** Minimum outdoor temperature at which the heat pump runs (requires an outdoor temperature source). Select **N/A** or **0 - 90** for Fahrenheit (**-18 - 31** for Celsius). Default setting: **N/A**.
- **Short Cycle Timeout:** The minimum off time between system calls. Select **30 seconds, 60 seconds, or 180 seconds** (default).

- **Auxiliary Heat Balance Point:** Maximum outdoor temperature at which Auxiliary heat system supplements the heat pump (requires an outdoor temperature sensor). Select **N/A** (default) or **0 - 90** for Fahrenheit (**-18 - 31** for Celsius).

**NOTES:** Auxiliary Heat Balance Point:

- Must be at least 1° higher than the Heat Pump Balance Point.
- Cannot be accessed for Dual Fuel systems.

# User Controls

Select **User Controls** and then configure these settings:

The image displays five screenshots of the 'USER CONTROLS' menu, arranged in three rows. Each screenshot shows a different configuration step:

- Top Left:** '1/5' step. Shows 'Auto Setpoint' set to 'Dual', 'Setpoint Units' set to '1F', and 'Temp Display Offset' set to '0.0'.
- Top Right:** '2/5' step. Shows 'Heat' mode with 'Lower Setpoint' at 38 and 'Upper Setpoint' at 89. A note below the upper setpoint reads '(must be 10° Greater than Lower Setpoint)'.
- Middle Left:** '3/5' step. Shows 'Cool' mode with 'Lower Setpoint' at 59 and 'Upper Setpoint' at 99. A note below the upper setpoint reads '(must be 10° Greater than Lower Setpoint)'.
- Middle Right:** '4/5' step. Shows 'Auto' mode with 'Lower Setpoint' at 59 and 'Upper Setpoint' at 99. A note below the upper setpoint reads '(must be 10° Greater than Lower Setpoint)'.
- Bottom:** '5/5' step. Shows 'Auto Deadband' set to '2.0'.

## NOTES:

- In Heat Only and Cool Only systems, the **Auto Setpoint** option is not available.
- In Cool Only systems, the **Heat Lower Setpoint** and **Heat Upper Setpoint** options are not available.
- In Heat Only systems, the **Cool Lower Setpoint** and **Cool Upper Setpoint** options are not available.
- In Heat Only or Cool Only systems or when **Auto Setpoint** is set to **Dual** or **Disable**, the **Auto Lower Setpoint** and **Auto Upper Setpoint** options are not available.
- In Heat Only or Cool Only systems or when **Auto Setpoint** is set to **Disable**, the **Auto Deadband** option is not available.

- **Auto Setpoint:** Defines how Auto mode operates. Select **Dual** (default) to use individual heat and cool setpoints, **Single** to use one setpoint for both heat and cool, or **Disabled** to turn off Auto mode.
- **Setpoint Units:** Defines the temperature scale and setpoint incrementation for the thermostat and sensors. Select **1F** (default), **1C**, or **0.5C**.
- **Temp Display Offset:** Adjusts an offset between the space temperature displayed and the temperature sensed. Select **-6** to **+6** for Fahrenheit or **-3.0** - **+3.0** for Celsius. The default setting is **0**.
- **Heat Lower Setpoint:** Limits the minimum heat setpoint the end user can set. Select **38 - 79** (Fahrenheit) or **3 - 27** (Celsius). The default setting is 38 (Fahrenheit) or 3 (Celsius)
- **Heat Upper Setpoint:** Limits the maximum heat setpoint the end user can set. The **Upper Setpoint** must be at least 10° (Fahrenheit) or 5° (Celsius) higher than the **Lower Setpoint**. Select **48 - 89** for (Fahrenheit) or **8 - 32** (Celsius). The default setting is 89 (Fahrenheit) or 32 (Celsius)
- **Cool Lower Setpoint:** Limits the minimum cool setpoint the end user can set. Select **38 - 89** (Fahrenheit) or **3 - 32** (Celsius). The default setting is 59 (Fahrenheit) or 15 (Celsius).
- **Cool Upper Setpoint:** Limits the maximum cool setpoint the end user can set. The **Upper Setpoint** must be at least 10° (Fahrenheit) or 5° (Celsius) higher than the **Lower Setpoint**. Select **48 - 99** for (Fahrenheit) or **8 - 37** (Celsius). The default setting is 99 (Fahrenheit) or 37 (Celsius).
- **Auto Lower Setpoint:** Limits the minimum auto setpoint the end user can set. Select **38 - 89** (Fahrenheit) or **3 - 32** (Celsius). The default setting is 59 (Fahrenheit) or 15 (Celsius).
- **Auto Upper Setpoint:** Limits the maximum auto setpoint the end user can set. The **Upper Setpoint** must be at least 10° (Fahrenheit) or 5° (Celsius) higher than the **Lower Setpoint**. Select **48 - 99** for (Fahrenheit) or **8 - 37** (Celsius). The default setting is 99 (Fahrenheit) or 37 (Celsius).
- **Auto Deadband:** This sets the separation between the heat and cool setpoints in Auto mode. In Dual Mode, this is the minimum separation allowed. Select **2.0** (default), **3.0**, **4.0**, **5.0**, or **6.0** for Fahrenheit or **1.0** (default), **2.0**, or **3.0** for Celsius.

# Sensor Setup

Select **Sensor Setup** and then configure these settings:

**NOTE:** Requires a slab remote sensor (CHV-RSS, sold separately).

SENSOR SETUP		SENSOR SETUP	
1/5		1/5	
Local Sensor Usage	<input type="text" value="Space"/>	Local Sensor Usage	<input type="text" value="Space"/>
TS1 Usage	<input type="text" value="Floor"/>	TS1 Usage	<input type="text" value="Floor"/>
TS2 Usage	<input type="text" value="Outdoor"/>	TS2 Usage	<input type="text" value="Omit"/>
Wall Type	<input type="text" value="Non-Insulated"/>	Wall Type	<input type="text" value="Non-Insulated"/>

SENSOR SETUP	
1/5	
Local Sensor Usage	<input type="text" value="Space"/>
TS1 Usage	<input type="text" value="Floor"/>
TS2 Usage	<input type="text" value="Omit"/>
Wall Type	<input type="text" value="Non-Insulated"/>

SENSOR SETUP	
2/5	
Local Sensor Temperature Trim	<input type="text" value="0.0"/>

SENSOR SETUP	
3/5	
TS1 Temperature Trim	<input type="text" value="0.0"/>
TS2 Temperature Trim	<input type="text" value="0.0"/>

SENSOR SETUP	
4/5	
Local Sensor Humidity Trim	<input type="text" value="0"/>

SENSOR SETUP	
5/5	
TS1 Humidity Trim	<input type="text" value="0"/>
TS2 Humidity Trim	<input type="text" value="0"/>

- **Local Sensor Usage:** Defines how the local sensor is used by the thermostat. Select **Omit** or **Space**.

- **Omit:** Omits channel from thermostat operation

**NOTE:** Sensor temperature and humidity can be output to the network even if Omit is selected.

- **Space:** Adds channel to space temperature/humidity average

- **TS1 Usage:** Defines how remote sensor channel 1 is used by the thermostat.
  - **Omit:** (Default) Omits channel from thermostat operation
  - **Space:** Adds channel to space temperature/humidity average
  - **Outdoor:** Adds channel to outdoor temperature/humidity average
  - **Floor:** Adds channel to slab (floor) temperature average
- **TS2 Usage:** Defines how remote sensor channel 2 is used by the thermostat.
  - **Omit:** (Default) Omits channel from thermostat operation
  - **Space:** Adds channel to space temperature/humidity average
  - **Outdoor:** Adds channel to outdoor temperature/humidity average
  - **Floor:** Adds channel to slab (floor) temperature average
- **Wall Type:** Defines the wall type that the thermostat is installed into for accurate temperature readings. Select **Non-Insulated** (hollow) or **Insulated**.
- **Local Sensor Temperature Trim:** Adjusts local sensor temperature measurement. Select **-6** to **+6** for Fahrenheit (**-3.0** to **+3.0** for Celsius). The default setting is **0**.
- **TS1 Temperature Trim:** Adjusts temperature sensed by temperature sensor(s) attached to TS1 input. Select **-6** to **+6** for Fahrenheit (**-3.0** to **+3.0** for Celsius). The default setting is **0**.
- **TS2 Temperature Trim:** Adjusts temperature sensed by temperature sensor(s) attached to TS2 input. Select **-6** to **+6** for Fahrenheit (**-3.0** to **+3.0** for Celsius). The default setting is **0**.
- **Local Sensor Humidity Trim:** Adjusts local sensor humidity percentage. Select **-9.0** to **+9.0**. The default setting is **0**.
- **TS1 Humidity Trim:** Adjusts humidity percentage sensed by temperature/humidity sensor attached to TS1 input. Select **-9.0** to **+9.0**. The default setting is **0**.
- **TS2 Humidity Trim:** Adjusts humidity percentage sensed by temperature/humidity sensor attached to TS2 input. Select **-9.0** to **+9.0**. The default setting is **0**.

## Humidistat Setup

Select **Humidistat Setup** and then configure these settings:

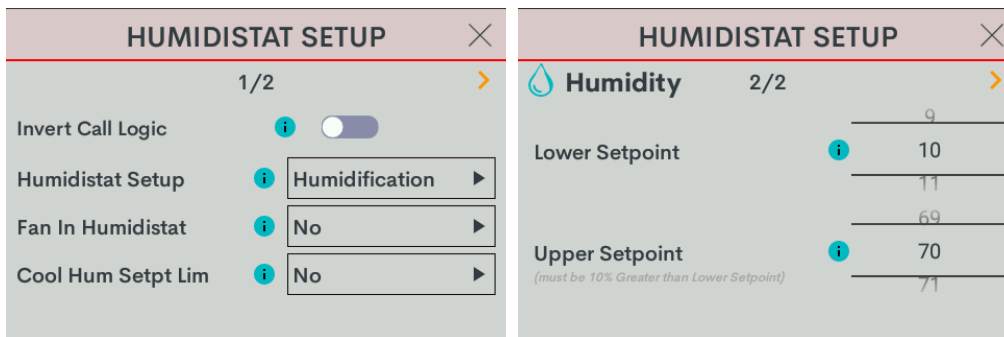

- **Invert Call Logic:** Change the HUM relay control logic for a humidifier or dehumidifier expecting a Normally Closed (NC) input. To invert the call logic, turn on the switch. The default setting is off for a Normally Open (NO) input.

- **Humidistat Setup:** Sets the operating mode of the HUM relay. Select **Humidification** (default), **Dehumidification**, or **Off**.
  - **Humidification:** Calls HUM relay when sensed humidity is below the humidistat setpoint.
  - **Dehumidification:** Calls HUM relay when sensed humidity is above the humidistat setpoint.
  - **Off:** Disable humidistat
- **Fan In Humidistat:** Select **No** (default) or **Yes**.

If **Yes**, the thermostat will make a fan call when a humidistat call is triggered instead of waiting for a heat or cool call to trigger the fan.
- **Cool Humidistat Setpoint Limit:** Limits internal humidistat setpoint to prevent window condensation when it is cold outside (displayed setpoint will not change). Select **No** (default) or **Yes**.
- **Lower Setpoint:** Limits the minimum humidistat setpoint percentage. Select **5 - 80**. The default setting is 10.
- **Upper Setpoint:** Limits the maximum humidistat setpoint percentage. Select **15 - 90**. The default setting is 70.

**NOTE:** The **Upper Setpoint** must be 10% higher than the **Lower Setpoint**.

# 2-Pipe FCU with 1 or 2 Stage Heat/Cool, with optional Radiant Floor Stage, optional Floor Warming, and optional Aux Heat Stage

The configuration below can function as a 2 pipe (single Hot/Cold supply/return pipe) multi-speed (up to 3 speed) fan coil unit with manual or auto heat/cool changeover and optional auxiliary heat.

Go to **Settings > Installer Settings > System Configuration** to open the **SYSTEM CONFIGURATION** screen.

Use the **System Type**, **System Performance**, **Radiant Floor**, **User Controls**, **Humidistat Setup**, and **Sensor Setup** options to configure the thermostat to work with the connected HVAC system.

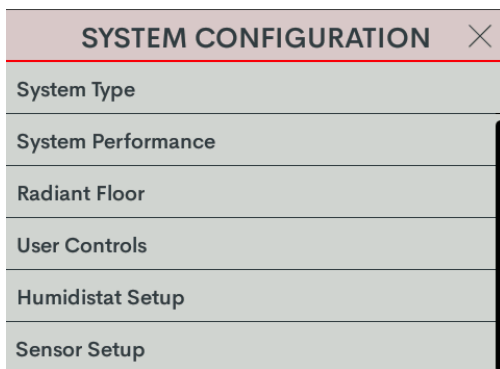

# System Type

Select **System Type** and then configure these settings:

SYSTEM TYPE	
System Type	FCU 2-Pipe He... ▶
Fan In Heat	No ▶
Heat Stages	1 ▶
Cool Stages	1 ▶

SYSTEM TYPE	
Fan Speeds	Low, Med, High ▶
Fan Speed Staging	Yes ▶
Compressor Stages	1 ▶
Aux Heat Stages	0 ▶

**NOTE:** When FCU 2-Pipe Heat/Cool is selected, the **Compressor Stages** option is not available.

- **System Type:** Select **FCU 2-Pipe Heat/Cool**.
- **Fan In Heat:** Call for fan during an AUX heat call. Available only when **Aux Heat Stages** is set to **1**. To call for fan during an AUX heat call, select **Yes**.
- **Heat Stages:** Number of heat-only stages present. Select **1**.
- **Cool Stages:** Number of cool-only (air conditioning) stages present. Select **1**.
- **Fan Speeds:** The number of fan speeds in the system. Select **Low, Med, High** (default), **Low, Med**, or **Low**.
- **Fan Speed Staging:** To adjust the fan speed based on system demand, select **Yes** (default). If the fan speed is fixed and adjusted manually, select **No**.
- **Aux Heat Stages:** The number of auxiliary (Aux) heat stages in the system. To define the number of Aux Heat Stages, select **0** (default) or **1**. If set to **1**, use the **Fan in Heat** option to configure the fan.

# System Performance

Select **System Performance** and then configure these settings:

## NOTES:

- When FCU 2-Pipe Heat/Cool is selected, the **Heat Pump Balance Point** and **Aux Heat Balance Point** options are not available.
- If **Aux Heat Stages** is set to **0**, **Radiant Floor** is set to **None** or **Floor Warming**, and **Heat Stages** and **Cool Stages** are set to **1**, the **Interstage Differential** and **Accumulated Staging Index** options are not available.

The image displays three sequential screenshots of the 'SYSTEM PERFORMANCE' settings menu. Each screenshot shows a different page of settings, indicated by a progress indicator (1/3, 2/3, 3/3) and a right-pointing arrow. The settings are as follows:

- Page 1 (1/3):** Heat Anticipator (3), Cool Anticipator (3), Interstage Diff (2.0).
- Page 2 (2/3):** Accum. Staging Index (3), H.Pump Balance Point (N/A).
- Page 3 (3/3):** Short Cycle Timeout (180 sec.), Aux Heat Balance Point (N/A).

- **Heat Anticipator:** Select **1, 2, 3** (default), **4, 5**, or **6**.  
For example, to adjust space heating system cycling characteristics, select **1** for more frequent cycles and faster responses or **6** for less frequent cycles and slower responses.
- **Cool Anticipator:** Select **1, 2, 3** (default), **4, 5**, or **6**.  
For example, to adjust cooling system cycling characteristics, select **1** for more frequent cycles and faster responses or **6** for less frequent cycles and slower responses.
- **Interstage Differential:** The proportional temperature error to trigger the next stage. Select **0.5 - 8.0** for Fahrenheit or **0.2 - 4.5** for Celsius. The default setting is **2.0** for Fahrenheit and **1.0** for Celsius.

- **Accumulated Staging Index:** Triggers the next stage to meet demand in instances where the previous stage cannot reach the Interstage Differential or achieve the desired setpoint. Select **1, 2, 3** (default), **4, 5**, or **6**.  
For example, select **1** for a faster trigger to the next stage or **5** for a slower trigger to the next stage. Setting **6** disables this feature altogether.
- **Short Cycle Timeout:** The minimum off time between system calls. Select **30 seconds, 60 seconds,** or **180 seconds** (default).

## Radiant Floor

Select **Radiant Floor** and then configure these settings:

**NOTE:** When setting **Radiant Floor** to **Space Heat** or **Floor Warm/Space Heat**, the Radiant Floor will be used as the first stage of heat and any Heat Stages setup under **SYSTEM TYPE** will be additional stages of heat.

- **Radiant Type:** Select **Floor Warm/Space Heat**.
  - **None:** No Radiant Floor present
  - **Floor Warming:** Radiant Floor temperature maintained at Radiant Floor Setpoint when used for Floor Warming. Radiant Floor heat call on W2
  - **Space Heating:** Radiant Floor used as space heat stage with definable Max Temperature. Radiant Floor heat call on W2.
  - **Floor Warming/Space Heating:** Radiant Floor is available for use as a floor warming stage and as a space heating stage. When operating as a floor warming stage, the floor temperature will be the same as the Radiant Floor Setpoint or higher. When operating as a space heating stage, the floor temperature is limited by the Radiant Floor Max Temperature. Radiant Floor heat call made on W2.
- **Regulation Index:** Select **1, 2, 3** (default), **4, 5**, or **6**.  
For example, to adjust Floor Warming system cycling characteristics, select **1** for a narrow temperature regulation or **6** for a wide temperature regulation.

**NOTE:** The **Regulation Index** option is not available when Space Heating is selected.

- **Max Temperature:** Used to prevent the floor from becoming too hot during long heat calls. Select **50 - 110** (Fahrenheit) or **10 - 43** (Celsius). The default setting is **110** for Fahrenheit and **43** for Celsius.

**NOTE:** The **Max Temperature** option is not available when Floor Warming is selected.

## User Controls

Select **User Controls** and then configure these settings:

**NOTE:** When **FCU 2-Pipe Heat/Cool** is selected and no changeover sensor is assigned, the **Auto Setpoint** and **Auto Deadband** options are not available.

The image displays five screenshots of the 'USER CONTROLS' menu, each showing a different mode and its associated settings. Each screen has a close button (X) in the top right corner.

- 1/5:** General settings.
  - Auto Setpoint: Dual
  - Setpoint Units: 1F
  - Temp Display Offset: 0.0
- 2/5 (Heat):** Heat mode settings.
  - Lower Setpoint: 38
  - Upper Setpoint: 89 (must be 10° Greater than Lower Setpoint)
- 3/5 (Cool):** Cool mode settings.
  - Lower Setpoint: 59
  - Upper Setpoint: 99 (must be 10° Greater than Lower Setpoint)
- 4/5 (Auto):** Auto mode settings.
  - Lower Setpoint: 59
  - Upper Setpoint: 99 (must be 10° Greater than Lower Setpoint)
- 5/5:** Auto Deadband settings.
  - Auto Deadband: 2.0

- **Auto Setpoint:** Defines how Auto mode operates. Select **Dual** (default) to use individual heat and cool setpoints, **Single** to use one setpoint for both heat and cool, or **Disabled** to turn off Auto mode.

- **Setpoint Units:** Defines the temperature scale and setpoint incrementation for the thermostat and sensors. Select **1F** (default), **1C**, or **0.5C**.
- **Temp Display Offset:** Adjusts an offset between the space temperature displayed and the temperature sensed. Select **-6** to **+6** for Fahrenheit (**-3.0** - **+3.0** for Celsius). The default setting is **0**.
- **Heat Lower Setpoint:** Limits the minimum heat setpoint the end user can set. Select **38 - 79** (Fahrenheit) or **3 - 27** (Celsius). The default setting is 38 (Fahrenheit) or 3 (Celsius)
- **Heat Upper Setpoint:** Limits the maximum heat setpoint the end user can set. The **Upper Setpoint** must be at least 10° (Fahrenheit) or 5° (Celsius) higher than the **Lower Setpoint**. Select **48 - 89** for (Fahrenheit) or **8 - 32** (Celsius). The default setting is 89 (Fahrenheit) or 32 (Celsius)
- **Cool Lower Setpoint:** Limits the minimum cool setpoint the end user can set. Select **38 - 89** (Fahrenheit) or **3 - 32** (Celsius). The default setting is 59 (Fahrenheit) or 15 (Celsius).
- **Cool Upper Setpoint:** Limits the maximum cool setpoint the end user can set. The **Upper Setpoint** must be at least 10° (Fahrenheit) or 5° (Celsius) higher than the **Lower Setpoint**. Select **48 - 99** for (Fahrenheit) or **8 - 37** (Celsius). The default setting is 99 (Fahrenheit) or 37 (Celsius).
- **Auto Lower Setpoint:** Limits the minimum auto setpoint the end user can set. Select **38 - 89** (Fahrenheit) or **3 - 32** (Celsius). The default setting is 59 (Fahrenheit) or 15 (Celsius).
- **Auto Upper Setpoint:** Limits the maximum auto setpoint the end user can set. The **Upper Setpoint** must be at least 10° (Fahrenheit) or 5° (Celsius) higher than the **Lower Setpoint**. Select **48 - 99** for (Fahrenheit) or **8 - 37** (Celsius). The default setting is 99 (Fahrenheit) or 37 (Celsius).
- **Auto Deadband:** This sets the separation between the heat and cool setpoints in Auto mode. In Dual Mode, this is the minimum separation allowed. Select **2.0** (default), **3.0**, **4.0**, **5.0**, or **6.0** for Fahrenheit or **1.0** (default), **2.0**, or **3.0** for Celsius.

## Humidistat Setup

Select **Humidistat Setup** and then configure these settings:

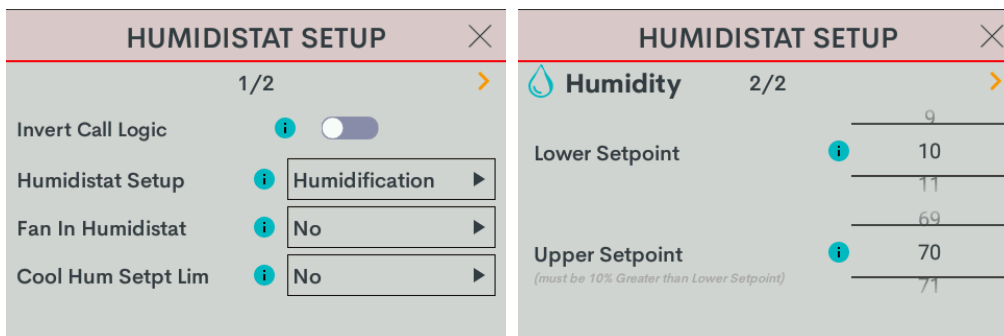

- **Invert Call Logic:** Change the HUM relay control logic for a humidifier or dehumidifier expecting a Normally Closed (NC) input. To invert the call logic, turn on the switch. The default setting is off for a Normally Open (NO) input.

- **Humidistat Setup:** Sets the operating mode of the HUM relay. Select **Humidification** (default), **Dehumidification**, or **Off**.
  - **Humidification:** Calls HUM relay when sensed humidity is below the humidistat setpoint.
  - **Dehumidification:** Calls HUM relay when sensed humidity is above the humidistat setpoint.
  - **Off:** Disable humidistat
- **Fan In Humidistat:** Select **No** (default) or **Yes**.

If **Yes**, the thermostat will make a fan call when a humidistat call is triggered instead of waiting for a heat or cool call to trigger the fan.
- **Cool Humidistat Setpoint Limit:** Limits internal humidistat setpoint to prevent window condensation when it is cold outside (displayed setpoint will not change). Select **No** (default) or **Yes**.
- **Lower Setpoint:** Limits the minimum humidistat setpoint percentage. Select **5 - 80**. The default setting is 10.
- **Upper Setpoint:** Limits the maximum humidistat setpoint percentage. Select **15 - 90**. The default setting is 70.

**NOTE:** The **Upper Setpoint** must be 10% higher than the **Lower Setpoint**.

# Sensor Setup

Select **Sensor Setup** and then configure these settings:

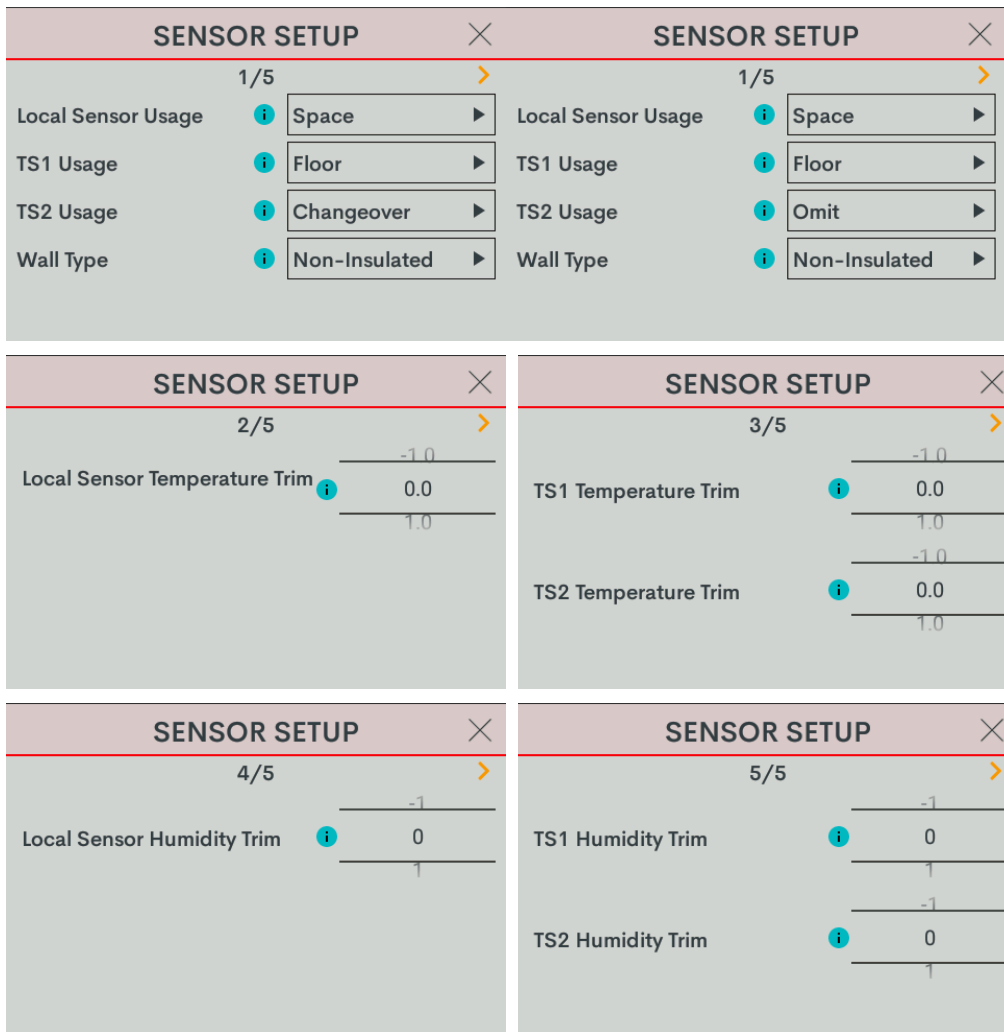

- **Local Sensor Usage:** Defines how the local sensor is used by the thermostat. Select **Omit** or **Space**.

- **Omit:** Omits channel from thermostat operation

**NOTE:** Sensor temperature and humidity can be output to the network even if Omit is selected.

- **Space:** Adds channel to space temperature/humidity average

- **TS1 Usage:** Defines how remote sensor channel 1 is used by the thermostat.
  - **Omit:** (Default) Omits channel from thermostat operation
  - **Space:** Adds channel to space temperature/humidity average
  - **Outdoor:** Adds channel to outdoor temperature/humidity average
  - **Floor:** Adds channel to slab (floor) temperature average
  - **Changeover:** Used to determine if the thermostat should be operating in Heat or Cool mode. The changeover sensor should be placed on the feed pipe. Only one sensor (TS1 or TS2) can be designated as the changeover sensor. The changeover option is only available for the **FCU 2-Pipe Heat/Cool** system type.
- **TS2 Usage:** Defines how remote sensor channel 2 is used by the thermostat.
  - **Omit:** (Default) Omits channel from thermostat operation
  - **Space:** Adds channel to space temperature/humidity average
  - **Outdoor:** Adds channel to outdoor temperature/humidity average
  - **Floor:** Adds channel to slab (floor) temperature average
  - **Changeover:** Used to determine if the thermostat should be operating in Heat or Cool mode. The changeover sensor should be placed on the feed pipe. Only one sensor (TS1 or TS2) can be designated as the changeover sensor. The changeover option is only available for the **FCU 2-Pipe Heat/Cool** system type.
- **Wall Type:** Defines the wall type that the thermostat is installed into for accurate temperature readings. Select **Non-Insulated** (hollow) or **Insulated**.
- **Local Sensor Temperature Trim:** Adjusts local sensor temperature measurement. Select **-6** to **+6** for Fahrenheit (**-3.0** to **+3.0** for Celsius). The default setting is **0**.
- **TS1 Temperature Trim:** Adjusts temperature sensed by temperature sensor(s) attached to TS1 input. Select **-6** to **+6** for Fahrenheit (**-3.0** to **+3.0** for Celsius). The default setting is **0**.
- **TS2 Temperature Trim:** Adjusts temperature sensed by temperature sensor(s) attached to TS2 input. Select **-6** to **+6** for Fahrenheit (**-3.0** to **+3.0** for Celsius). The default setting is **0**.
- **Local Sensor Humidity Trim:** Adjusts local sensor humidity percentage. Select **-9.0** to **+9.0**. The default setting is **0**.
- **TS1 Humidity Trim:** Adjusts humidity percentage sensed by temperature/humidity sensor attached to TS1 input. Select **-9.0** to **+9.0**. The default setting is **0**.
- **TS2 Humidity Trim:** Adjusts humidity percentage sensed by temperature/humidity sensor attached to TS2 input. Select **-9.0** to **+9.0**. The default setting is **0**.

# 2-Pipe FCU with 1 or 2 Stage Heat, with optional Radiant Floor Stage, optional Floor Warming, and optional Aux Heat Stage

The configuration below can function as a 2 pipe (supply/return ) heat only, multi-speed (up to 3 speed) fan coil unit with optional auxiliary heat.

Go to **Settings > Installer Settings > System Configuration** to open the **SYSTEM CONFIGURATION** screen.

Use the **System Type**, **System Performance**, **Radiant Floor**, **User Controls**, **Humidistat Setup**, and **Sensor Setup** options to configure the thermostat to work with the connected HVAC system.

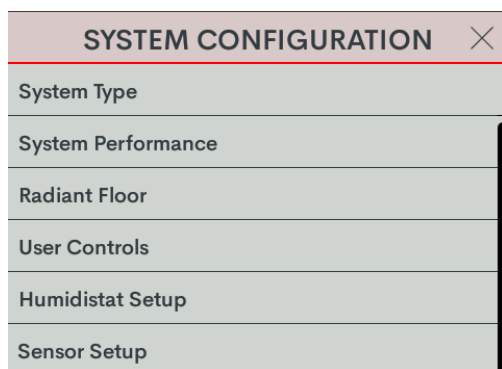

# System Type

Select **System Type** and then configure these settings:

SYSTEM TYPE	
System Type	FCU 2-Pipe Heat
Fan In Heat	No
Heat Stages	1
Cool Stages	1

SYSTEM TYPE	
Fan Speeds	Low, Med, High
Fan Speed Staging	Yes
Compressor Stages	1
Aux Heat Stages	0

**NOTE:** When **FCU 2-Pipe Heat** is selected, the **Cool Stages** and **Compressor Stages** options are not available.

- **System Type:** Select **FCU 2-Pipe Heat**.
- **Fan In Heat:** Call for fan during an AUX heat call. Available only when **Aux Heat Stages** is set to **1**. To call for fan during an AUX heat call, select **Yes**.
- **Heat Stages:** Number of heat-only stages present. Select **1**.
- **Fan Speeds:** The number of fan speeds in the system. Select **Low, Med, High** (default), **Low, Med**, or **Low**.
- **Fan Speed Staging:** To adjust the fan speed based on system demand, select **Yes** (default). If the fan speed is fixed and adjusted manually, select **No**.
- **Aux Heat Stages:** The number of auxiliary (Aux) heat stages in the system. To define the number of Aux Heat Stages, select **0** (default) or **1**. If set to **1**, use the **Fan in Heat** option to configure the fan.

# System Performance

Select **System Performance** and then configure these settings:

**NOTE:** When FCU 2-Pipe Heat is selected, the **Cool Anticipator**, **H. Pump Balance Point** and **Aux Heat Balance Point** options are not available.

The image displays three sequential screenshots of the 'SYSTEM PERFORMANCE' configuration interface. Each screenshot shows a different step in the configuration process, indicated by a progress indicator (1/3, 2/3, 3/3) and a right-pointing arrow. The settings are as follows:

- Screenshot 1 (1/3):** Heat Anticipator: 3; Cool Anticipator: 3; Interstage Diff: 2.0.
- Screenshot 2 (2/3):** Accum. Staging Index: 3; H.Pump Balance Point: N/A.
- Screenshot 3 (3/3):** Short Cycle Timeout: 180 sec.; Aux Heat Balance Point: N/A.

- **Heat Anticipator:** Select **1, 2, 3** (default), **4, 5**, or **6**.  
For example, to adjust space heating system cycling characteristics, select **1** for more frequent cycles and faster responses or **6** for less frequent cycles and slower responses.
- **Interstage Differential:** The proportional temperature error to trigger the next stage. Select **0.5 - 8.0** for Fahrenheit or **0.2 - 4.5** for Celsius. The default setting is **2.0** for Fahrenheit and **1.0** for Celsius.
- **Accumulated Staging Index:** Triggers the next stage to meet demand in instances where the previous stage cannot reach the Interstage Differential or achieve the desired setpoint. Select **1, 2, 3** (default), **4, 5**, or **6**.  
For example, select **1** for a faster trigger to the next stage or **5** for a slower trigger to the next stage. Setting **6** disables this feature altogether.
- **Short Cycle Timeout:** The minimum off time between system calls. Select **30 seconds, 60 seconds, or 180 seconds** (default).

# Radiant Floor

Select **Radiant Floor** and then configure these settings:

**NOTE:** When setting **Radiant Floor** to **Space Heat** or **Floor Warm/Space Heat**, the Radiant Floor will be used as the first stage of heat and any Heat Stages setup under **SYSTEM TYPE** will be additional stages of heat.

RADIANT FLOOR 1/2		RADIANT FLOOR 2/2	
Radiant Type	Floor Warm/Sp...	Lower Setpoint	38
Regulation Index	3		39
	108		109
Max Temperature	109	Upper Setpoint	110
	110		(must be 10° Greater than Lower Setpoint)

- **Radiant Type:** Select **Floor Warm/Space Heat**

- **None:** No Radiant Floor present
- **Floor Warming:** Radiant Floor temperature maintained at Radiant Floor Setpoint when used for Floor Warming. Radiant Floor heat call on W2
- **Space Heating:** Radiant Floor used as space heat stage with definable Max Temperature. Radiant Floor heat call on W2.
- **Floor Warming/Space Heating:** Radiant Floor is available for use as a floor warming stage and as a space heating stage. When operating as a floor warming stage, the floor temperature will be the same as the Radiant Floor Setpoint or higher. When operating as a space heating stage, the floor temperature is limited by the Radiant Floor Max Temperature. Radiant Floor heat call made on W2.

- **Regulation Index:** Select **1, 2, 3** (default), **4, 5**, or **6**.

For example, to adjust Floor Warming system cycling characteristics, select 1 for a narrow temperature regulation or 6 for a wide temperature regulation.

**NOTE:** The **Regulation Index** option is not available when Space Heating is selected.

- **Max Temperature:** Used to prevent the floor from becoming too hot during long heat calls. Select **50 - 110** (Fahrenheit) or **10 - 43** (Celsius). The default setting is **110** for Fahrenheit and **43** for Celsius.

**NOTE:** The **Max Temperature** option is not available when Floor Warming is selected.

# User Controls

Select **User Controls** and then configure these settings:

**NOTE:** If **System Type** is set to **FCU 2-Pipe Heat**, the **Auto Setpoint**, **Auto Deadband**, **Auto Lower Setpoint**, **Auto Upper Setpoint**, **Heat Lower Setpoint**, and **Heat Upper Setpoint** options are not available.

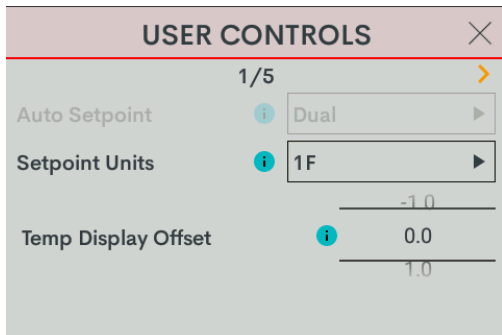

- **Setpoint Units:** Defines the temperature scale and setpoint incrementation for the thermostat and sensors. Select **1F** (default), **1C**, or **0.5C**.
- **Temp Display Offset:** Adjusts an offset between the space temperature displayed and the temperature sensed. Select **-6** to **+6** for Fahrenheit (**-3.0** - **+3.0** for Celsius). The default setting is **0**.

# Humidistat Setup

Select **Humidistat Setup** and then configure these settings:

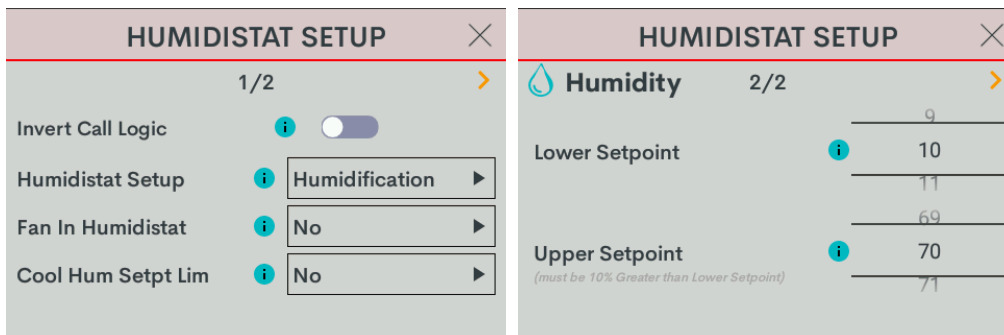

- **Invert Call Logic:** Change the HUM relay control logic for a humidifier or dehumidifier expecting a Normally Closed (NC) input. To invert the call logic, turn on the switch. The default setting is off for a Normally Open (NO) input.

- **Humidistat Setup:** Sets the operating mode of the HUM relay. Select **Humidification** (default), **Dehumidification**, or **Off**.
  - **Humidification:** Calls HUM relay when sensed humidity is below the humidistat setpoint.
  - **Dehumidification:** Calls HUM relay when sensed humidity is above the humidistat setpoint.
  - **Off:** Disable humidistat
- **Fan In Humidistat:** Select **No** (default) or **Yes**.

If **Yes**, the thermostat will make a fan call when a humidistat call is triggered instead of waiting for a heat or cool call to trigger the fan.
- **Cool Humidistat Setpoint Limit:** Limits internal humidistat setpoint to prevent window condensation when it is cold outside (displayed setpoint will not change). Select **No** (default) or **Yes**.
- **Lower Setpoint:** Limits the minimum humidistat setpoint percentage. Select **5 - 80**. The default setting is 10.
- **Upper Setpoint:** Limits the maximum humidistat setpoint percentage. Select **15 - 90**. The default setting is 70.

**NOTE:** The **Upper Setpoint** must be 10% higher than the **Lower Setpoint**.

# Sensor Setup

Select **Sensor Setup** and then configure these settings:

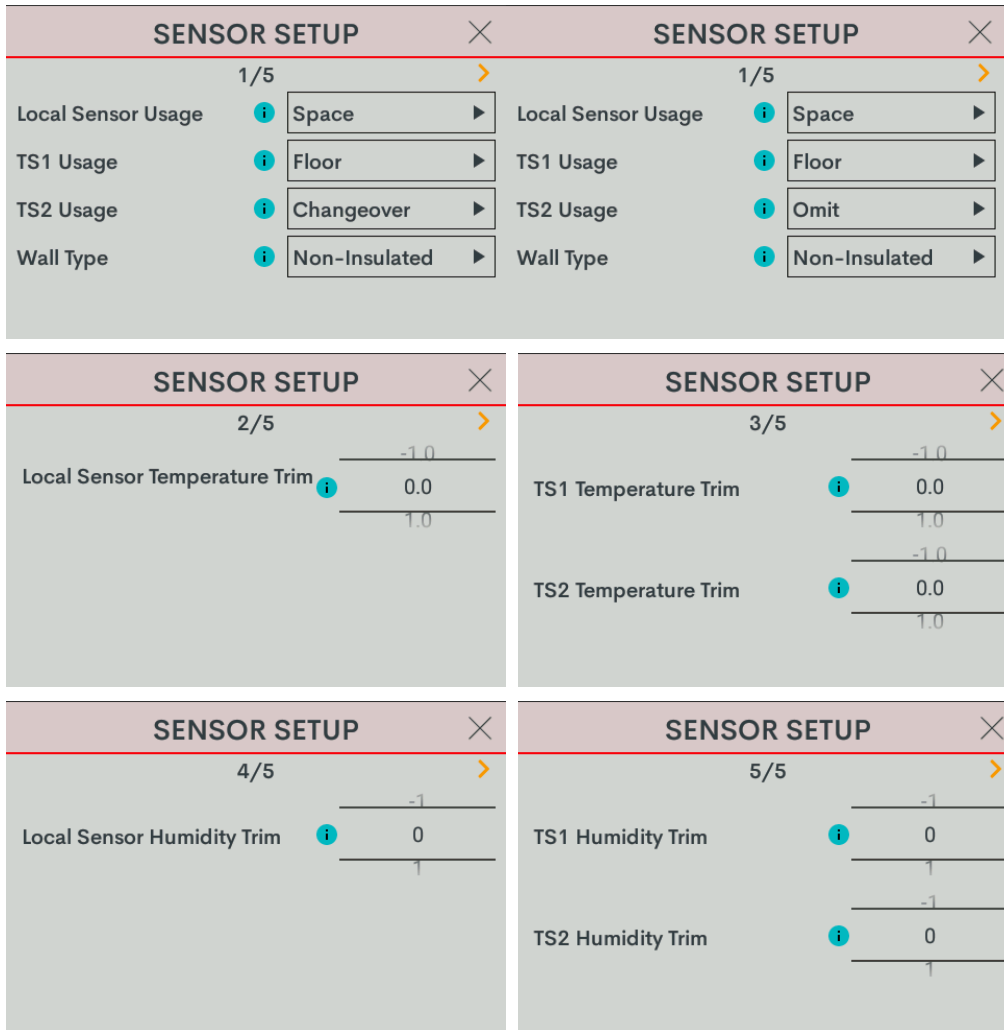

- **Local Sensor Usage:** Defines how the local sensor is used by the thermostat. Select **Omit** or **Space**.

- **Omit:** Omits channel from thermostat operation

**NOTE:** Sensor temperature and humidity can be output to the network even if Omit is selected.

- **Space:** Adds channel to space temperature/humidity average

- **TS1 Usage:** Defines how remote sensor channel 1 is used by the thermostat.
  - **Omit:** (Default) Omits channel from thermostat operation
  - **Space:** Adds channel to space temperature/humidity average
  - **Outdoor:** Adds channel to outdoor temperature/humidity average
  - **Floor:** Adds channel to slab (floor) temperature average
  - **Changeover:** Used to determine if the thermostat should be operating in Heat or Cool mode. The changeover sensor should be placed on the feed pipe. Only one sensor (TS1 or TS2) can be designated as the changeover sensor. The changeover option is only available for the **FCU 2-Pipe Heat/Cool** system type.
- **TS2 Usage:** Defines how remote sensor channel 2 is used by the thermostat.
  - **Omit:** (Default) Omits channel from thermostat operation
  - **Space:** Adds channel to space temperature/humidity average
  - **Outdoor:** Adds channel to outdoor temperature/humidity average
  - **Floor:** Adds channel to slab (floor) temperature average
  - **Changeover:** Used to determine if the thermostat should be operating in Heat or Cool mode. The changeover sensor should be placed on the feed pipe. Only one sensor (TS1 or TS2) can be designated as the changeover sensor. The changeover option is only available for the **FCU 2-Pipe Heat/Cool** system type.
- **Wall Type:** Defines the wall type that the thermostat is installed into for accurate temperature readings. Select **Non-Insulated** (hollow) or **Insulated**.
- **Local Sensor Temperature Trim:** Adjusts local sensor temperature measurement. Select **-6** to **+6** for Fahrenheit (**-3.0** to **+3.0** for Celsius). The default setting is **0**.
- **TS1 Temperature Trim:** Adjusts temperature sensed by temperature sensor(s) attached to TS1 input. Select **-6** to **+6** for Fahrenheit (**-3.0** to **+3.0** for Celsius). The default setting is **0**.
- **TS2 Temperature Trim:** Adjusts temperature sensed by temperature sensor(s) attached to TS2 input. Select **-6** to **+6** for Fahrenheit (**-3.0** to **+3.0** for Celsius). The default setting is **0**.
- **Local Sensor Humidity Trim:** Adjusts local sensor humidity percentage. Select **-9.0** to **+9.0**. The default setting is **0**.
- **TS1 Humidity Trim:** Adjusts humidity percentage sensed by temperature/humidity sensor attached to TS1 input. Select **-9.0** to **+9.0**. The default setting is **0**.
- **TS2 Humidity Trim:** Adjusts humidity percentage sensed by temperature/humidity sensor attached to TS2 input. Select **-9.0** to **+9.0**. The default setting is **0**.

# 2-Pipe FCU with 1 or 2 Stage Cool, with optional Radiant Floor Stage, optional Floor Warming, and optional Aux Heat Stage

The configuration below can function as a 2 pipe (supply/return ) cool only, multi-speed (up to 3 speed) fan coil unit with optional auxiliary heat.

Go to **Settings > Installer Settings > System Configuration** to open the **SYSTEM CONFIGURATION** screen.

Use the **System Type**, **System Performance**, **Radiant Floor**, **User Controls**, **Humidistat Setup**, and **Sensor Setup** options to configure the thermostat to work with the connected HVAC system.

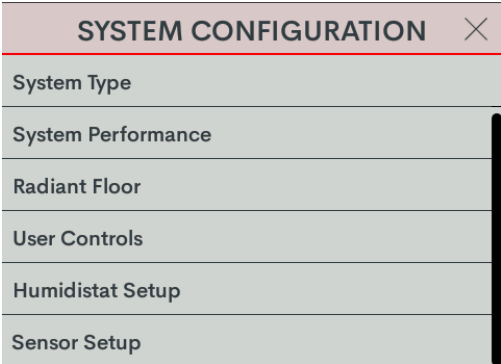

# System Type

Select **System Type** and then configure these settings:

SYSTEM TYPE	
1/2	>
System Type	FCU 2-Pipe Cool
Fan In Heat	Yes
Heat Stages	1
Cool Stages	1

SYSTEM TYPE	
2/2	>
Fan Speeds	Low, Med, High
Fan Speed Staging	Yes
Compressor Stages	1
Aux Heat Stages	0

**NOTE:** When **FCU 2-Pipe Cool** is selected, the **Fan In Heat**, **Heat Stages**, and **Compressor Stages** options are not available.

- **System Type:** Select **FCU 2-Pipe Cool**.
- **Fan In Heat:** Call for fan during an AUX heat call. Available only when **Aux Heat Stages** is set to **1**. To call for fan during an AUX heat call, select **Yes**.
- **Cool Stages:** Number of cool-only (air conditioning) stages present. Select **1**.
- **Fan Speeds:** The number of fan speeds in the system. Select **Low, Med, High** (default), **Low, Med**, or **Low**.
- **Fan Speed Staging:** To adjust the fan speed based on system demand, select **Yes** (default). If the fan speed is fixed and adjusted manually, select **No**.
- **Aux Heat Stages:** The number of auxiliary heat stages in the system. If using auxiliary heat, select **1**; otherwise select **0** (default).

# System Performance

Select **System Performance** and then configure these settings:

## NOTES:

- When FCU 2-Pipe Cool is selected, the **Heat Pump Balance Point** and **Aux Heat Balance Point** options are not available.
- If **Aux Heat Stages** is set to **0**, **Radiant Floor** is set to **None** or **Floor Warming**, and **Cool Stages** is set to **1**, the **Interstage Differential** and **Accumulated Staging Index** options are not available.

The image displays three sequential screenshots of the 'SYSTEM PERFORMANCE' configuration window. Each window has a title bar with 'SYSTEM PERFORMANCE' and a close button (X). The first window shows settings for '1/3' with 'Heat Anticipator' set to 3, 'Cool Anticipator' set to 3, and 'Interstage Diff' set to 2.0. The second window shows settings for '2/3' with 'Accum. Staging Index' set to 3 and 'H.Pump Balance Point' set to N/A. The third window shows settings for '3/3' with 'Short Cycle Timeout' set to 180 sec. and 'Aux Heat Balance Point' set to N/A. Each setting includes an information icon (i) and a right-pointing arrow.

- **Heat Anticipator:** Select **1, 2, 3** (default), **4, 5**, or **6**.  
For example, to adjust space heating system cycling characteristics, select **1** for more frequent cycles and faster responses or **6** for less frequent cycles and slower responses.
- **Cool Anticipator:** Select **1, 2, 3** (default), **4, 5**, or **6**.  
For example, to adjust cooling system cycling characteristics, select **1** for more frequent cycles and faster responses or **6** for less frequent cycles and slower responses.
- **Interstage Differential:** The proportional temperature error to trigger the next stage. Select **0.5 - 8.0** for Fahrenheit or **0.2 - 4.5** for Celsius. The default setting is **2.0** for Fahrenheit and **1.0** for Celsius.

- **Accumulated Staging Index:** Triggers the next stage to meet demand in instances where the previous stage cannot reach the Interstage Differential or achieve the desired setpoint. Select **1, 2, 3** (default), **4, 5**, or **6**.

For example, select **1** for a faster trigger to the next stage or **5** for a slower trigger to the next stage. Setting **6** disables this feature altogether.

- **Short Cycle Timeout:** The minimum off time between system calls. Select **30 seconds, 60 seconds,** or **180 seconds** (default).

## Radiant Floor

Select **Radiant Floor** and then configure these settings:

**NOTE:** When setting **Radiant Floor** to **Space Heat** or **Floor Warm/Space Heat**, the Radiant Floor will be used as the first stage of heat and any Heat Stages setup under **SYSTEM TYPE** will be additional stages of heat.

- **Radiant Type:** Select **Floor Warm/Space Heat**.
  - **None:** No Radiant Floor present
  - **Floor Warming:** Radiant Floor temperature maintained at Radiant Floor Setpoint when used for Floor Warming. Radiant Floor heat call on W2
  - **Space Heating:** Radiant Floor used as space heat stage with definable Max Temperature. Radiant Floor heat call on W2.
  - **Floor Warming/Space Heating:** Radiant Floor is available for use as a floor warming stage and as a space heating stage. When operating as a floor warming stage, the floor temperature will be the same as the Radiant Floor Setpoint or higher. When operating as a space heating stage, the floor temperature is limited by the Radiant Floor Max Temperature. Radiant Floor heat call made on W2.

- **Regulation Index:** Select **1, 2, 3** (default), **4, 5**, or **6**.

For example, to adjust Floor Warming system cycling characteristics, select **1** for a narrow temperature regulation or **6** for a wide temperature regulation.

**NOTE:** The **Regulation Index** option is not available when Space Heating is selected.

- **Max Temperature:** Used to prevent the floor from becoming too hot during long heat calls. Select **50 - 110** (Fahrenheit) or **10 - 43** (Celsius). The default setting is **110** for Fahrenheit and **43** for Celsius.

**NOTE:** The **Max Temperature** option is not available when Floor Warming is selected.

## User Controls

Select **User Controls** and then configure these settings:

**NOTE:** If **Radiant Type** is set to **None** or **Floor Warming** and **Aux Heat** is set to **0**, the **Auto Setpoint**, **Auto Deadband**, **Auto Lower Setpoint**, **Auto Upper Setpoint**, **Heat Lower Setpoint**, and **Heat Upper Setpoint** options are not available.

**USER CONTROLS** ✕

1/5 >

Auto Setpoint ⓘ Dual ▶

Setpoint Units ⓘ 1F ▶

Temp Display Offset ⓘ 0.0

-1.0  
1.0

**USER CONTROLS** ✕

Heat 2/5 >

Lower Setpoint ⓘ 38

39  
88

Upper Setpoint ⓘ 89

(must be 10° Greater than Lower Setpoint)

**USER CONTROLS** ✕

Cool 3/5 >

Lower Setpoint ⓘ 59

58  
60  
98

Upper Setpoint ⓘ 99

(must be 10° Greater than Lower Setpoint)

**USER CONTROLS** ✕

Auto 4/5 >

Lower Setpoint ⓘ 59

58  
60  
98

Upper Setpoint ⓘ 99

(must be 10° Greater than Lower Setpoint)

**USER CONTROLS** ✕

5/5 >

Auto Deadband ⓘ 2.0

3.0

- **Auto Setpoint:** Defines how Auto mode operates. Select **Dual** (default) to use individual heat and cool setpoints, **Single** to use one setpoint for both heat and cool, or **Disabled** to turn off Auto mode.

- **Setpoint Units:** Defines the temperature scale and setpoint incrementation for the thermostat and sensors. Select **1F** (default), **1C**, or **0.5C**.
- **Temp Display Offset:** Adjusts an offset between the space temperature displayed and the temperature sensed. Select **-6** to **+6** for Fahrenheit (**-3.0** - **+3.0** for Celsius). The default setting is 0.
- **Heat Lower Setpoint:** Limits the minimum heat setpoint the end user can set. Select **38 - 79** (Fahrenheit) or **3 - 27** (Celsius). The default setting is 38 (Fahrenheit) or 3 (Celsius)
- **Heat Upper Setpoint:** Limits the maximum heat setpoint the end user can set. The **Upper Setpoint** must be at least 10° (Fahrenheit) or 5° (Celsius) higher than the **Lower Setpoint**. Select **48 - 89** for (Fahrenheit) or **8 - 32** (Celsius). The default setting is 89 (Fahrenheit) or 32 (Celsius)
- **Cool Lower Setpoint:** Limits the minimum cool setpoint the end user can set. Select **38 - 89** (Fahrenheit) or **3 - 32** (Celsius). The default setting is 59 (Fahrenheit) or 15 (Celsius).
- **Cool Upper Setpoint:** Limits the maximum cool setpoint the end user can set. The **Upper Setpoint** must be at least 10° (Fahrenheit) or 5° (Celsius) higher than the **Lower Setpoint**. Select **48 - 99** for (Fahrenheit) or **8 - 37** (Celsius). The default setting is 99 (Fahrenheit) or 37 (Celsius).
- **Auto Lower Setpoint:** Limits the minimum auto setpoint the end user can set. Select **38 - 89** (Fahrenheit) or **3 - 32** (Celsius). The default setting is 59 (Fahrenheit) or 15 (Celsius).
- **Auto Upper Setpoint:** Limits the maximum auto setpoint the end user can set. The **Upper Setpoint** must be at least 10° (Fahrenheit) or 5° (Celsius) higher than the **Lower Setpoint**. Select **48 - 99** for (Fahrenheit) or **8 - 37** (Celsius). The default setting is 99 (Fahrenheit) or 37 (Celsius).
- **Auto Deadband:** This sets the separation between the heat and cool setpoints in Auto mode. In Dual Mode, this is the minimum separation allowed. Select **2.0** (default), **3.0**, **4.0**, **5.0**, or **6.0** for Fahrenheit or **1.0** (default), **2.0**, or **3.0** for Celsius.

## Humidistat Setup

Select **Humidistat Setup** and then configure these settings:

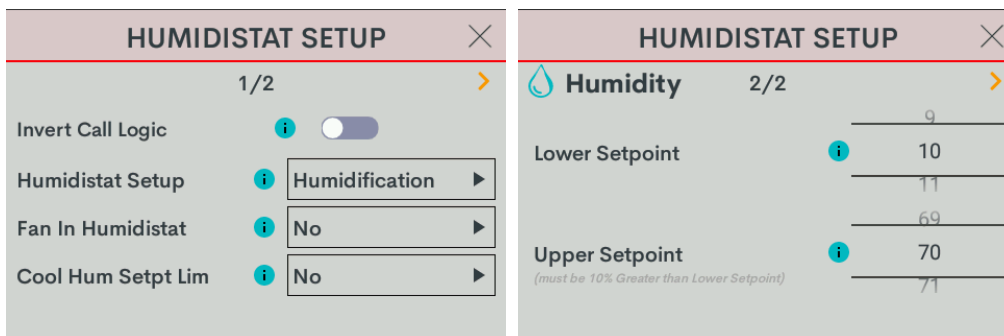

- **Invert Call Logic:** Change the HUM relay control logic for a humidifier or dehumidifier expecting a Normally Closed (NC) input. To invert the call logic, turn on the switch. The default setting is off for a Normally Open (NO) input.

- **Humidistat Setup:** Sets the operating mode of the HUM relay. Select **Humidification** (default), **Dehumidification**, or **Off**.
  - **Humidification:** Calls HUM relay when sensed humidity is below the humidistat setpoint.
  - **Dehumidification:** Calls HUM relay when sensed humidity is above the humidistat setpoint.
  - **Off:** Disable humidistat
- **Fan In Humidistat:** Select **No** (default) or **Yes**.

If **Yes**, the thermostat will make a fan call when a humidistat call is triggered instead of waiting for a heat or cool call to trigger the fan.
- **Cool Humidistat Setpoint Limit:** Limits internal humidistat setpoint to prevent window condensation when it is cold outside (displayed setpoint will not change). Select **No** (default) or **Yes**.
- **Lower Setpoint:** Limits the minimum humidistat setpoint percentage. Select **5 - 80**. The default setting is 10.
- **Upper Setpoint:** Limits the maximum humidistat setpoint percentage. Select **15 - 90**. The default setting is 70.

**NOTE:** The **Upper Setpoint** must be 10% higher than the **Lower Setpoint**.

# Sensor Setup

Select **Sensor Setup** and then configure these settings:

SENSOR SETUP		SENSOR SETUP	
1/5		1/5	
Local Sensor Usage	<input type="text" value="Space"/>	Local Sensor Usage	<input type="text" value="Space"/>
TS1 Usage	<input type="text" value="Floor"/>	TS1 Usage	<input type="text" value="Floor"/>
TS2 Usage	<input type="text" value="Outdoor"/>	TS2 Usage	<input type="text" value="Omit"/>
Wall Type	<input type="text" value="Non-Insulated"/>	Wall Type	<input type="text" value="Non-Insulated"/>

SENSOR SETUP	
1/5	
Local Sensor Usage	<input type="text" value="Space"/>
TS1 Usage	<input type="text" value="Floor"/>
TS2 Usage	<input type="text" value="Omit"/>
Wall Type	<input type="text" value="Non-Insulated"/>

SENSOR SETUP	
2/5	
Local Sensor Temperature Trim	<input type="text" value="0.0"/>

SENSOR SETUP	
3/5	
TS1 Temperature Trim	<input type="text" value="0.0"/>
TS2 Temperature Trim	<input type="text" value="0.0"/>

SENSOR SETUP	
4/5	
Local Sensor Humidity Trim	<input type="text" value="0"/>

SENSOR SETUP	
5/5	
TS1 Humidity Trim	<input type="text" value="0"/>
TS2 Humidity Trim	<input type="text" value="0"/>

- **Local Sensor Usage:** Defines how the local sensor is used by the thermostat. Select **Omit** or **Space**.

- **Omit:** Omits channel from thermostat operation

**NOTE:** Sensor temperature and humidity can be output to the network even if Omit is selected.

- **Space:** Adds channel to space temperature/humidity average

- **TS1 Usage:** Defines how remote sensor channel 1 is used by the thermostat.
  - **Omit:** (Default) Omits channel from thermostat operation
  - **Space:** Adds channel to space temperature/humidity average
  - **Outdoor:** Adds channel to outdoor temperature/humidity average
  - **Floor:** Adds channel to slab (floor) temperature average
- **TS2 Usage:** Defines how remote sensor channel 2 is used by the thermostat.
  - **Omit:** (Default) Omits channel from thermostat operation
  - **Space:** Adds channel to space temperature/humidity average
  - **Outdoor:** Adds channel to outdoor temperature/humidity average
  - **Floor:** Adds channel to slab (floor) temperature average
- **Wall Type:** Defines the wall type that the thermostat is installed into for accurate temperature readings. Select **Non-Insulated** (hollow) or **Insulated**.
- **Local Sensor Temperature Trim:** Adjusts local sensor temperature measurement. Select **-6** to **+6** for Fahrenheit (**-3.0** to **+3.0** for Celsius). The default setting is **0**.
- **TS1 Temperature Trim:** Adjusts temperature sensed by temperature sensor(s) attached to TS1 input. Select **-6** to **+6** for Fahrenheit (**-3.0** to **+3.0** for Celsius). The default setting is **0**.
- **TS2 Temperature Trim:** Adjusts temperature sensed by temperature sensor(s) attached to TS2 input. Select **-6** to **+6** for Fahrenheit (**-3.0** to **+3.0** for Celsius). The default setting is **0**.
- **Local Sensor Humidity Trim:** Adjusts local sensor humidity percentage. Select **-9.0** to **+9.0**. The default setting is **0**.
- **TS1 Humidity Trim:** Adjusts humidity percentage sensed by temperature/humidity sensor attached to TS1 input. Select **-9.0** to **+9.0**. The default setting is **0**.
- **TS2 Humidity Trim:** Adjusts humidity percentage sensed by temperature/humidity sensor attached to TS2 input. Select **-9.0** to **+9.0**. The default setting is **0**.

# 4-Pipe FCU 1 Stage Heat/Cool, with optional Radiant Floor Stage, optional Floor Warming, and optional Aux Heat Stage

The configuration below can function as a 4 pipe (separate Hot/Cold supply/return pipes) multi-speed (up to 3 speed) fan coil unit with optional auxiliary heat.

Go to **Settings > Installer Settings > System Configuration** to open the **SYSTEM CONFIGURATION** screen.

Use the **System Type**, **System Performance**, **Radiant Floor**, **User Controls**, **Humidistat Setup**, and **Sensor Setup** options to configure the thermostat to work with the connected HVAC system.

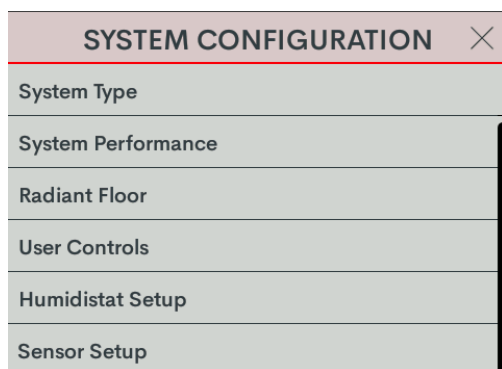

# System Type

Select **System Type** and then configure these settings:

The image shows two screenshots of the 'SYSTEM TYPE' configuration interface. The first screenshot shows the 'SYSTEM TYPE' dropdown set to 'FCU 4-Pipe'. The second screenshot shows the configuration options for 'FCU 4-Pipe'.

Setting	Value
System Type	FCU 4-Pipe
Fan In Heat	No
Heat Stages	1
Cool Stages	1
Fan Speeds	Low, Med, High
Fan Speed Staging	Yes
Compressor Stages	1
Aux Heat Stages	0

**NOTE:** When **FCU 4-Pipe** is selected, the **Heat Stages**, **Cool Stages**, and **Compressor Stages** options are not available.

- **System Type:** Select **FCU 4-Pipe**.
- **Fan In Heat:** Call for fan during an AUX heat call. Available only when **Aux Heat Stages** is set to **1**. To call for fan during an AUX heat call, select **Yes**.
- **Fan Speeds:** The number of fan speeds in the system. Select **Low, Med, High** (default), **Low, Med**, or **Low**.
- **Fan Speed Staging:** To adjust the fan speed based on system demand, select **Yes** (default). If the fan speed is fixed and adjusted manually, select **No**.
- **Aux Heat Stages:** The number of auxiliary heat stages in the system. If using auxiliary heat, select **1**; otherwise select **0** (default).

# System Performance

Select **System Performance** and then configure these settings:

## NOTES:

- When FCU 4-Pipe is selected, the **Heat Pump Balance Point** and **Aux Heat Balance Point** options are not available.
- If **Aux Heat Stages** is set to **0** and **Radiant Floor** is set to **None** or **Floor Warming**, the **Interstage Differential** and **Accumulated Staging Index** options are not available.

The image displays three sequential screenshots of the 'SYSTEM PERFORMANCE' configuration interface. Each screenshot shows a different page of settings, indicated by a page number (1/3, 2/3, 3/3) and a right-pointing arrow. Each setting includes an information icon (i) and a right-pointing arrow.

- Page 1/3:** Heat Anticipator (3), Cool Anticipator (3), Interstage Diff (2.0).
- Page 2/3:** Accum. Staging Index (3), H.Pump Balance Point (N/A).
- Page 3/3:** Short Cycle Timeout (180 sec.), Aux Heat Balance Point (N/A).

- **Heat Anticipator:** Select **1, 2, 3** (default), **4, 5**, or **6**.  
For example, to adjust space heating system cycling characteristics, select **1** for more frequent cycles and faster responses or **6** for less frequent cycles and slower responses.
- **Cool Anticipator:** Select **1, 2, 3** (default), **4, 5**, or **6**.  
For example, to adjust cooling system cycling characteristics, select **1** for more frequent cycles and faster responses or **6** for less frequent cycles and slower responses.
- **Interstage Differential:** The proportional temperature error to trigger the next stage. Select **0.5 - 8.0** for Fahrenheit or **0.2 - 4.5** for Celsius. The default setting is **2.0** for Fahrenheit and **1.0** for Celsius.

- **Accumulated Staging Index:** Triggers the next stage to meet demand in instances where the previous stage cannot reach the Interstage Differential or achieve the desired setpoint. Select **1, 2, 3** (default), **4, 5**, or **6**.

For example, select **1** for a faster trigger to the next stage or **5** for a slower trigger to the next stage. Setting **6** disables this feature altogether.

- **Short Cycle Timeout:** The minimum off time between system calls. Select **30 seconds, 60 seconds,** or **180 seconds** (default).

## Radiant Floor

Select **Radiant Floor** and then configure these settings:

**NOTE:** When setting **Radiant Floor** to **Space Heat** or **Floor Warm/Space Heat**, the Radiant Floor will be used as the first stage of heat and any Heat Stages setup under **SYSTEM TYPE** will be additional stages of heat.

- **Radiant Type:** Select the type of radiant heating.
  - **None:** No Radiant Floor present
  - **Floor Warming:** Radiant Floor temperature maintained at Radiant Floor Setpoint when used for Floor Warming. Radiant Floor heat call on W2
  - **Space Heating:** Radiant Floor used as space heat stage with definable Max Temperature. Radiant Floor heat call on W2.
  - **Floor Warming/Space Heating:** Radiant Floor is available for use as a floor warming stage and as a space heating stage. When operating as a floor warming stage, the floor temperature will be the same as the Radiant Floor Setpoint or higher. When operating as a space heating stage, the floor temperature is limited by the Radiant Floor Max Temperature. Radiant Floor heat call made on W2.
- **Regulation Index:** Select **1, 2, 3** (default), **4, 5**, or **6**.

For example, to adjust Floor Warming system cycling characteristics, select **1** for a narrow temperature regulation or **6** for a wide temperature regulation.

**NOTE:** The **Regulation Index** option is not available when Space Heating is selected.

- **Max Temperature:** Used to prevent the floor from becoming too hot during long heat calls. Select **50 - 110** (Fahrenheit) or **10 - 43** (Celsius). The default setting is **110** for Fahrenheit and **43** for Celsius.

**NOTE:** The **Max Temperature** option is not available when Floor Warming is selected.

## User Controls

Select **User Controls** and then configure these settings:

The image displays five screenshots of the 'USER CONTROLS' menu, arranged in a grid. Each screenshot shows a different page of settings, indicated by a page number (1/5, 2/5, 3/5, 4/5, 5/5) and a right-pointing arrow. The settings are as follows:

- Screenshot 1 (1/5):** Shows 'Auto Setpoint' set to 'Dual', 'Setpoint Units' set to '1F', and 'Temp Display Offset' set to '0.0'.
- Screenshot 2 (2/5):** Shows 'Heat' mode with 'Lower Setpoint' at 38 and 'Upper Setpoint' at 89. A note below the upper setpoint reads '(must be 10° Greater than Lower Setpoint)'.
- Screenshot 3 (3/5):** Shows 'Cool' mode with 'Lower Setpoint' at 59 and 'Upper Setpoint' at 99. A note below the upper setpoint reads '(must be 10° Greater than Lower Setpoint)'.
- Screenshot 4 (4/5):** Shows 'Auto' mode with 'Lower Setpoint' at 59 and 'Upper Setpoint' at 99. A note below the upper setpoint reads '(must be 10° Greater than Lower Setpoint)'.
- Screenshot 5 (5/5):** Shows 'Auto Deadband' set to '2.0'.

- **Auto Setpoint:** Defines how Auto mode operates. Select **Dual** (default) to use individual heat and cool setpoints, **Single** to use one setpoint for both heat and cool, or **Disabled** to turn off Auto mode.
- **Setpoint Units:** Defines the temperature scale and setpoint incrementation for the thermostat and sensors. Select **1F** (default), **1C**, or **0.5C**.

- **Temp Display Offset:** Adjusts an offset between the space temperature displayed and the temperature sensed. Select **-6** to **+6** for Fahrenheit (**-3.0** - **+3.0** for Celsius). The default setting is 0.
- **Heat Lower Setpoint:** Limits the minimum heat setpoint the end user can set. Select **38 - 79** (Fahrenheit) or **3 - 27** (Celsius). The default setting is 38 (Fahrenheit) or 3 (Celsius)
- **Heat Upper Setpoint:** Limits the maximum heat setpoint the end user can set. The **Upper Setpoint** must be at least 10° (Fahrenheit) or 5° (Celsius) higher than the **Lower Setpoint**. Select **48 - 89** for (Fahrenheit) or **8 - 32** (Celsius). The default setting is 89 (Fahrenheit) or 32 (Celsius)
- **Cool Lower Setpoint:** Limits the minimum cool setpoint the end user can set. Select **38 - 89** (Fahrenheit) or **3 - 32** (Celsius). The default setting is 59 (Fahrenheit) or 15 (Celsius).
- **Cool Upper Setpoint:** Limits the maximum cool setpoint the end user can set. The **Upper Setpoint** must be at least 10° (Fahrenheit) or 5° (Celsius) higher than the **Lower Setpoint**. Select **48 - 99** for (Fahrenheit) or **8 - 37** (Celsius). The default setting is 99 (Fahrenheit) or 37 (Celsius).
- **Auto Lower Setpoint:** Limits the minimum auto setpoint the end user can set. Select **38 - 89** (Fahrenheit) or **3 - 32** (Celsius). The default setting is 59 (Fahrenheit) or 15 (Celsius).
- **Auto Upper Setpoint:** Limits the maximum auto setpoint the end user can set. The **Upper Setpoint** must be at least 10° (Fahrenheit) or 5° (Celsius) higher than the **Lower Setpoint**. Select **48 - 99** for (Fahrenheit) or **8 - 37** (Celsius). The default setting is 99 (Fahrenheit) or 37 (Celsius).
- **Auto Deadband:** This sets the separation between the heat and cool setpoints in Auto mode. In Dual Mode, this is the minimum separation allowed. Select **2.0** (default), **3.0**, **4.0**, **5.0**, or **6.0** for Fahrenheit or **1.0** (default), **2.0**, or **3.0** for Celsius.

## Humidistat Setup

Select **Humidistat Setup** and then configure these settings:

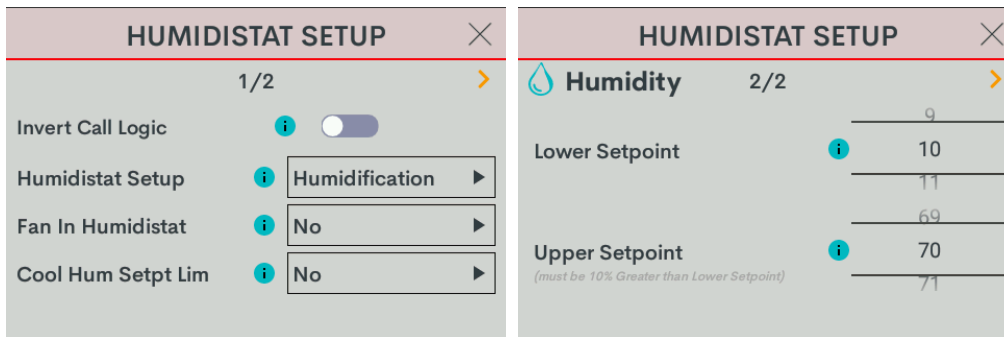

- **Invert Call Logic:** Change the HUM relay control logic for a humidifier or dehumidifier expecting a Normally Closed (NC) input. To invert the call logic, turn on the switch. The default setting is off for a Normally Open (NO) input.

- **Humidistat Setup:** Sets the operating mode of the HUM relay. Select **Humidification** (default), **Dehumidification**, or **Off**.
  - **Humidification:** Calls HUM relay when sensed humidity is below the humidistat setpoint.
  - **Dehumidification:** Calls HUM relay when sensed humidity is above the humidistat setpoint.
  - **Off:** Disable humidistat
- **Fan In Humidistat:** Select **No** (default) or **Yes**.

If **Yes**, the thermostat will make a fan call when a humidistat call is triggered instead of waiting for a heat or cool call to trigger the fan.
- **Cool Humidistat Setpoint Limit:** Limits internal humidistat setpoint to prevent window condensation when it is cold outside (displayed setpoint will not change). Select **No** (default) or **Yes**.
- **Lower Setpoint:** Limits the minimum humidistat setpoint percentage. Select **5 - 80**. The default setting is 10.
- **Upper Setpoint:** Limits the maximum humidistat setpoint percentage. Select **15 - 90**. The default setting is 70.

**NOTE:** The **Upper Setpoint** must be 10% higher than the **Lower Setpoint**.

# Sensor Setup

Select **Sensor Setup** and then configure these settings:

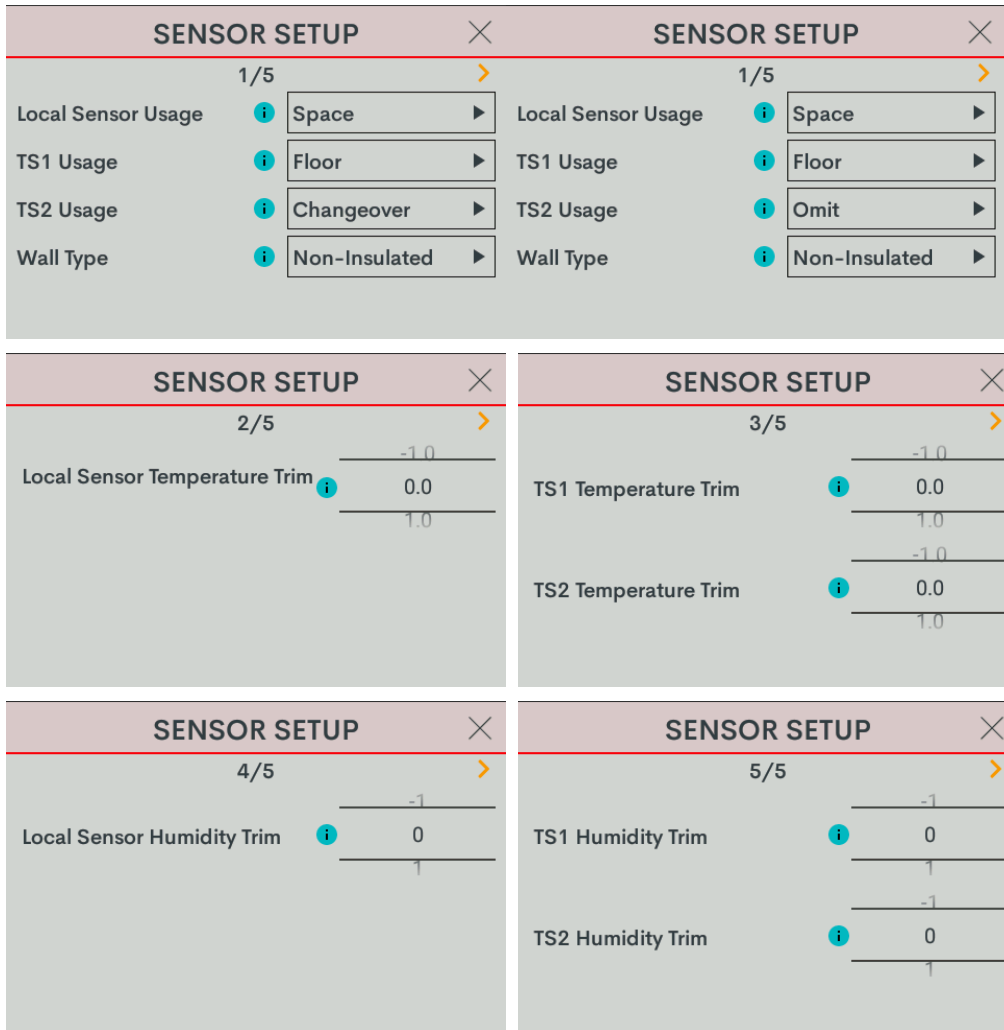

- **Local Sensor Usage:** Defines how the local sensor is used by the thermostat. Select **Omit** or **Space**.

- **Omit:** Omits channel from thermostat operation

**NOTE:** Sensor temperature and humidity can be output to the network even if Omit is selected.

- **Space:** Adds channel to space temperature/humidity average

- **TS1 Usage:** Defines how remote sensor channel 1 is used by the thermostat.
  - **Omit:** (Default) Omits channel from thermostat operation
  - **Space:** Adds channel to space temperature/humidity average
  - **Outdoor:** Adds channel to outdoor temperature/humidity average
  - **Floor:** Adds channel to slab (floor) temperature average
  - **Changeover:** Used to determine if the thermostat should be operating in Heat or Cool mode. The changeover sensor should be placed on the feed pipe. Only one sensor (TS1 or TS2) can be designated as the changeover sensor. The changeover option is only available for the **FCU 2-Pipe Heat/Cool** system type.
- **TS2 Usage:** Defines how remote sensor channel 2 is used by the thermostat.
  - **Omit:** (Default) Omits channel from thermostat operation
  - **Space:** Adds channel to space temperature/humidity average
  - **Outdoor:** Adds channel to outdoor temperature/humidity average
  - **Floor:** Adds channel to slab (floor) temperature average
  - **Changeover:** Used to determine if the thermostat should be operating in Heat or Cool mode. The changeover sensor should be placed on the feed pipe. Only one sensor (TS1 or TS2) can be designated as the changeover sensor. The changeover option is only available for the **FCU 2-Pipe Heat/Cool** system type.
- **Wall Type:** Defines the wall type that the thermostat is installed into for accurate temperature readings. Select **Non-Insulated** (hollow) or **Insulated**.
- **Local Sensor Temperature Trim:** Adjusts local sensor temperature measurement. Select **-6** to **+6** for Fahrenheit (**-3.0** to **+3.0** for Celsius). The default setting is **0**.
- **TS1 Temperature Trim:** Adjusts temperature sensed by temperature sensor(s) attached to TS1 input. Select **-6** to **+6** for Fahrenheit (**-3.0** to **+3.0** for Celsius). The default setting is **0**.
- **TS2 Temperature Trim:** Adjusts temperature sensed by temperature sensor(s) attached to TS2 input. Select **-6** to **+6** for Fahrenheit (**-3.0** to **+3.0** for Celsius). The default setting is **0**.
- **Local Sensor Humidity Trim:** Adjusts local sensor humidity percentage. Select **-9.0** to **+9.0**. The default setting is **0**.
- **TS1 Humidity Trim:** Adjusts humidity percentage sensed by temperature/humidity sensor attached to TS1 input. Select **-9.0** to **+9.0**. The default setting is **0**.
- **TS2 Humidity Trim:** Adjusts humidity percentage sensed by temperature/humidity sensor attached to TS2 input. Select **-9.0** to **+9.0**. The default setting is **0**.

# Operation

The HZ-THSTAT has a 3.5 in. LCD touch screen display used for configuring the thermostat to the HVAC system and monitoring the temperature and humidity.

## Overview

The images below provide a general overview of common user interface elements on the HZ-THSTAT during normal operation.

**NOTE:** The screenshots below show the thermostat with the Wi-Fi® network connected.

### User Interface - Time, Weather, and Navigation Controls

Time and weather automatically update when the thermostat is connected to a Wi-Fi network.

Tap the weather icon to display the current outdoor weather and the ten-day forecast.

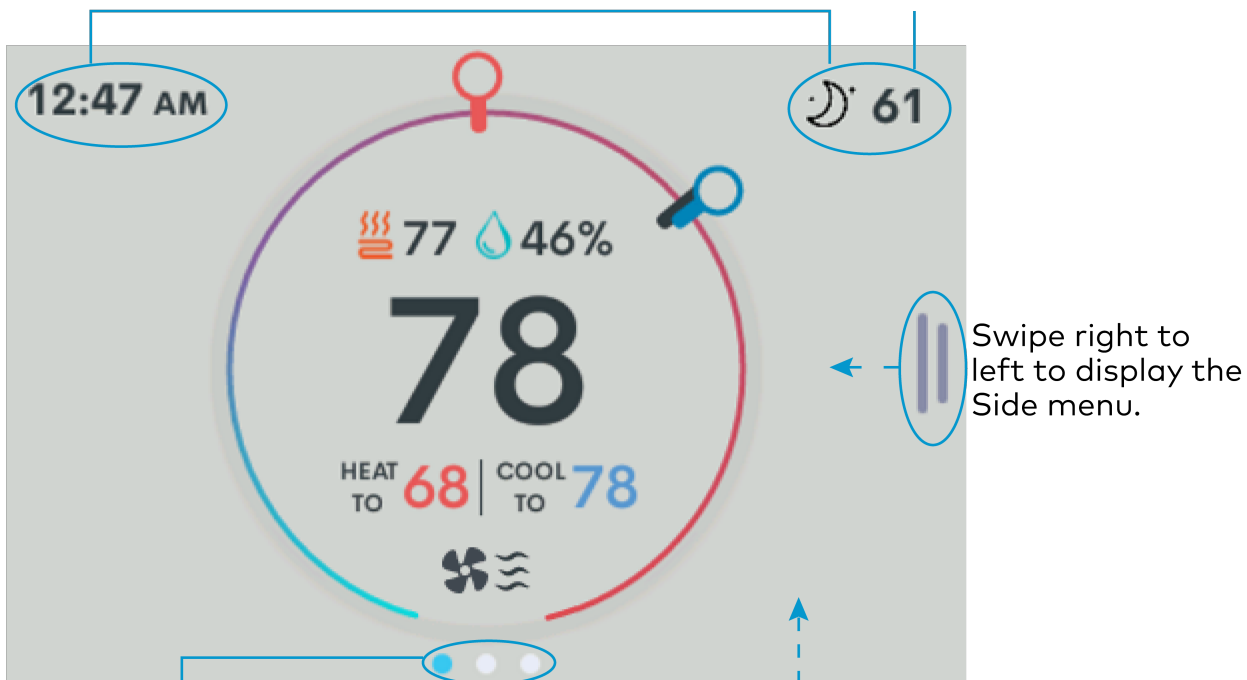

Swipe right to left to display the next page. More pages are added depending on the thermostat's configuration.

Swipe bottom to top to display the Brightness slider and access the setup screens.

### User Interface - System Controls

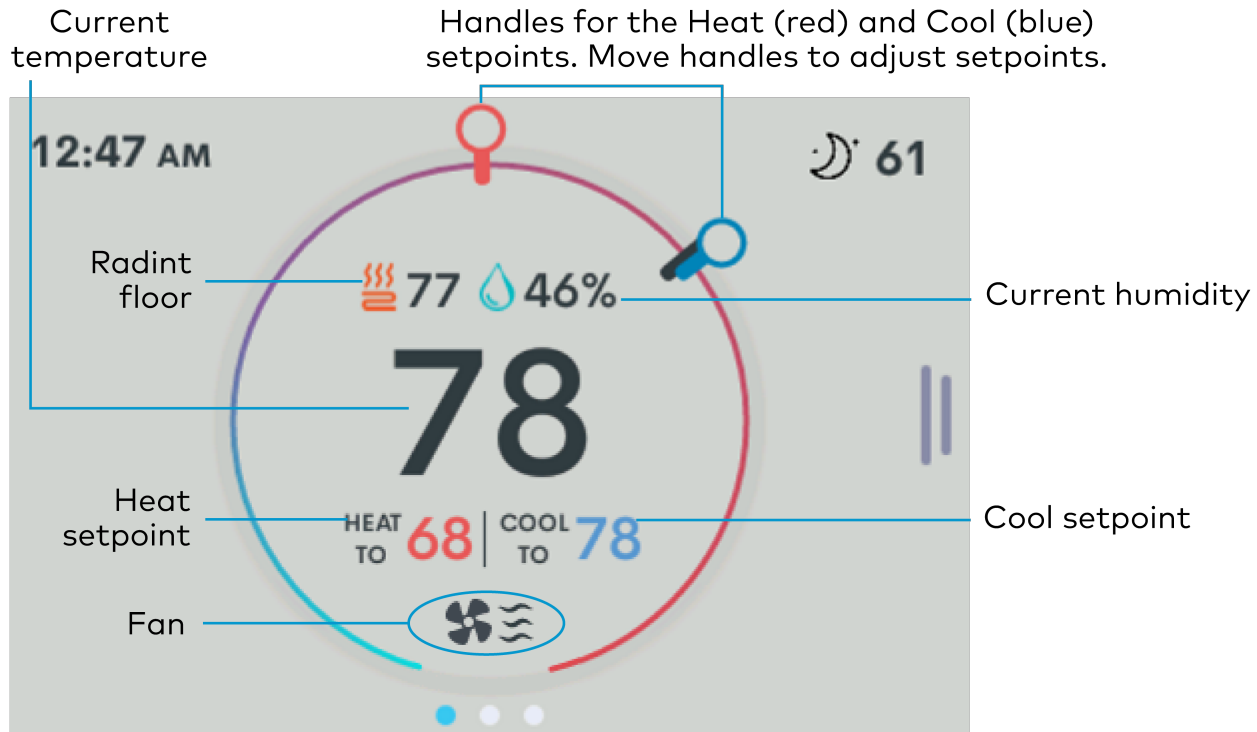

### User Interface - Error Icons

Radiant Floor is configured but no slab sensor is set up or a slab sensor is set up and is not connect-

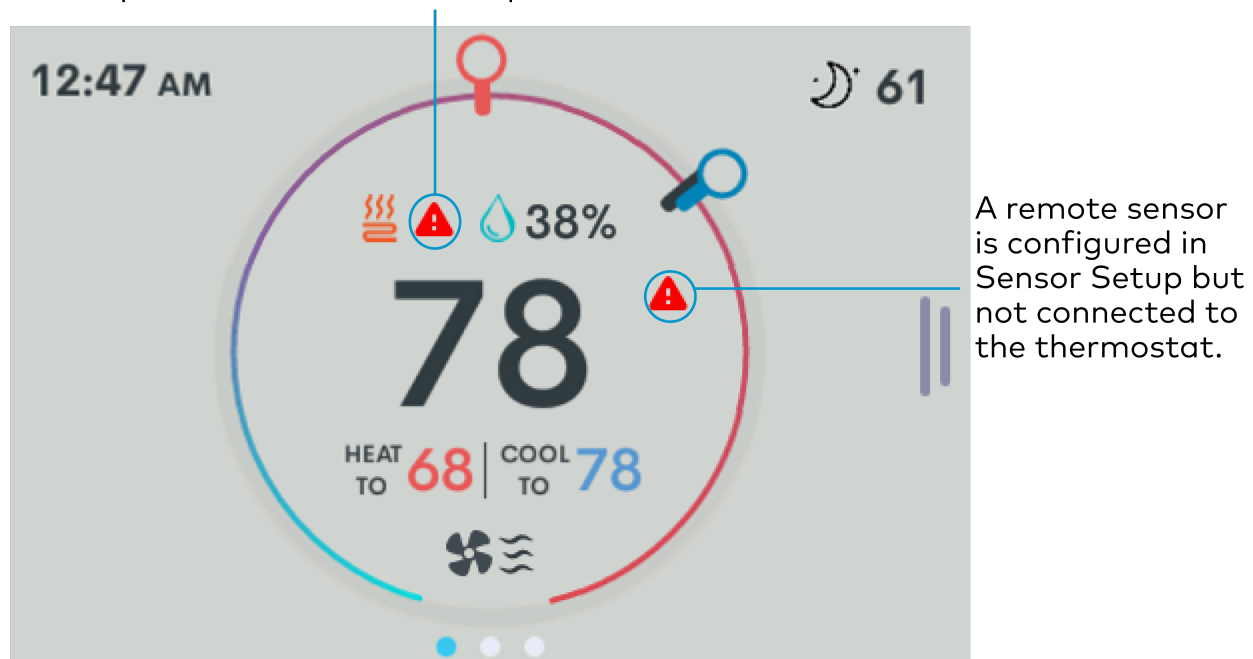

### User Interface - Short Cycle Message

When the thermostat makes a call during the Short Cycle time out, the "Please Wait" message is displayed.

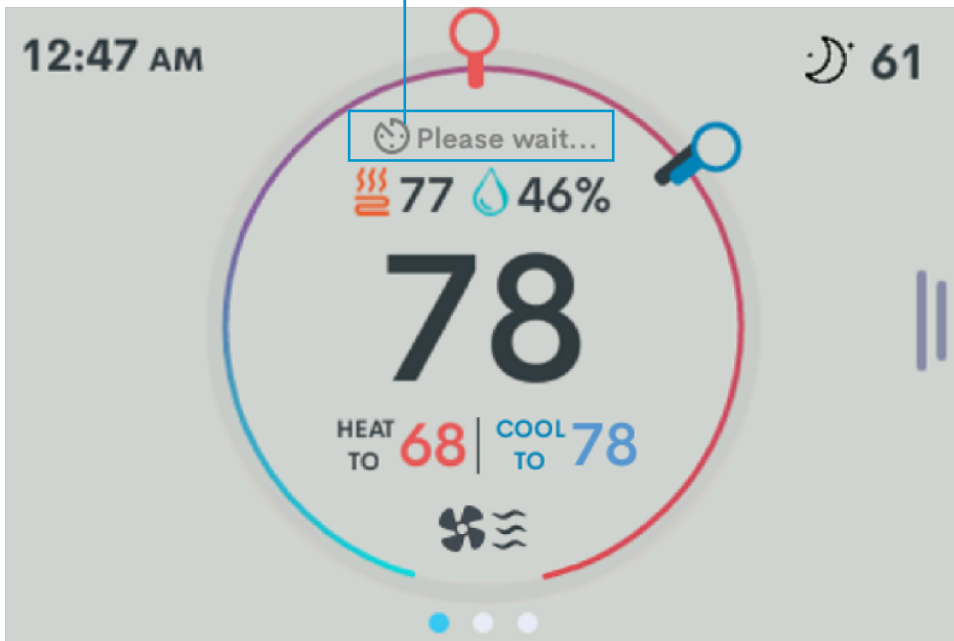

### User Interface - Wireless Disconnected

When the Wi-Fi network is not connected or not working, a line appears through the wireless symbol.

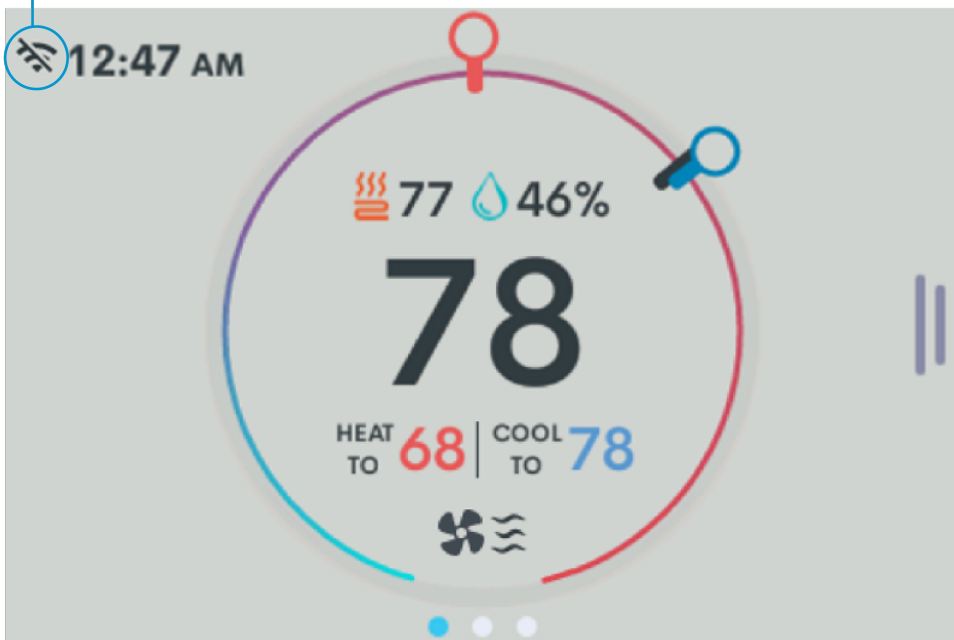

The images above represent the UI of a white (-W) thermostat in day mode. The Almond (-A) and Black (-B) thermostats have Almond and Dark themes, respectively.

In night mode, White and Almond thermostats switch to a dark theme and appear as shown below.

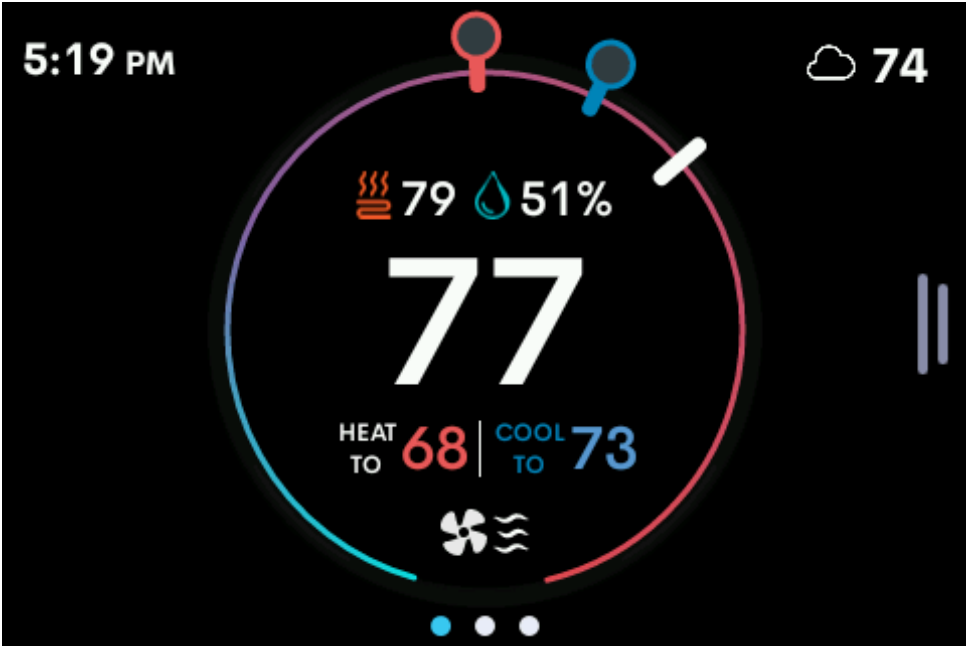

# Lightbar and Up and Down Buttons

Use the Up/Down buttons to change the heat and cool setpoints and to access the Installer Settings.

In Dual Setpoint mode, the thermostat attempts to assume which setpoint the user is adjusting when pressing the up or down button. To adjust a different setpoint, use the setpoint handle on the touch screen to assign the setpoint, or tap a setpoint handle to select it and then use the up and down buttons to assign the setpoint.

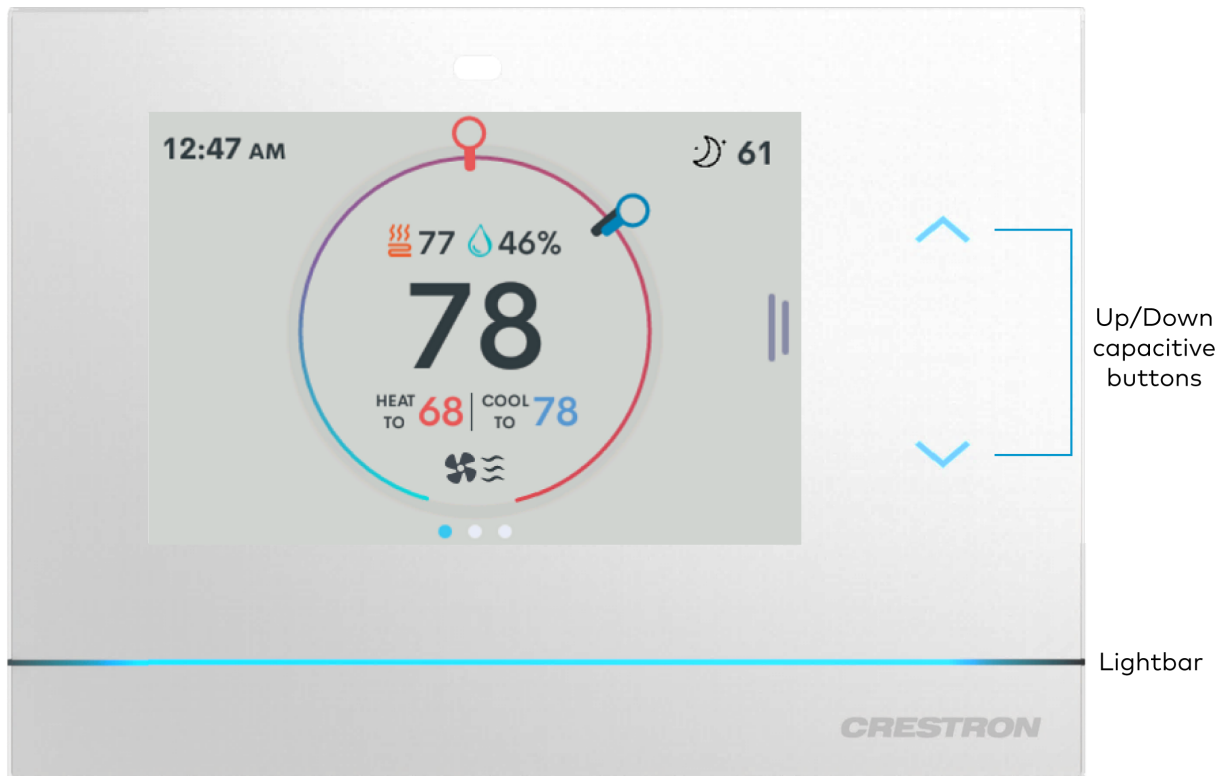

The RGB lightbar and capacitive Up/Down buttons change colors based on the call:

- Pulsing amber for heat calls
- Pulsing cyan for cool calls
- Pulsing white for fan-only calls
- Solid white for no calls

Day and Night themes for the LCD display also affect the lightbar and Up/Down buttons. For details, refer to [Display on page 175](#).

# Weather

Once connected to a Wi-Fi network and the location data is set on the [Location on page 183](#) screen, the weather icon reports the outdoor temperature. Tap the weather icon to open the current forecast and three days out of the ten-days forecast. Swipe right to left to scroll through the remaining six days.

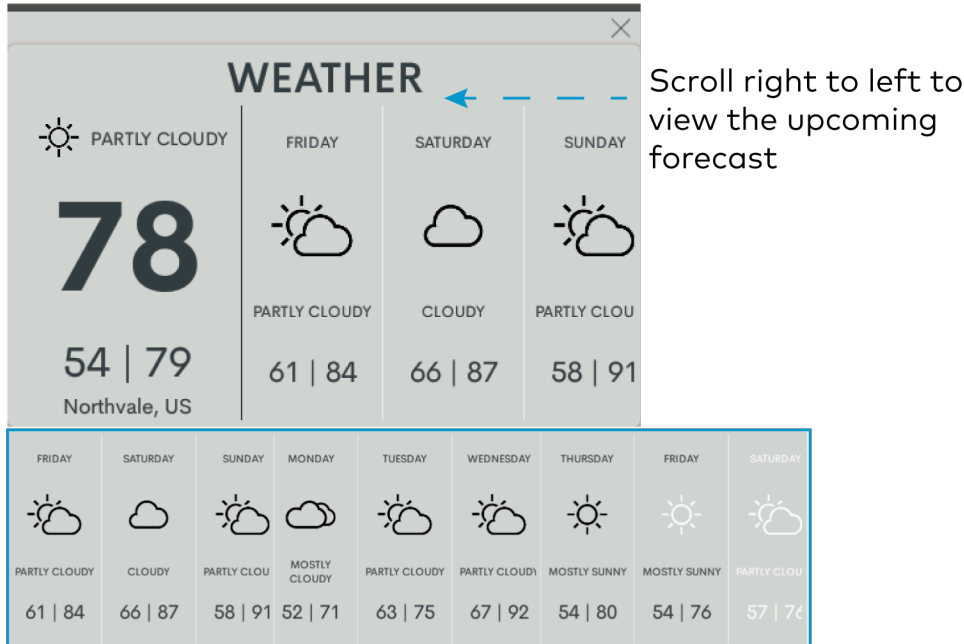

# Side Menu

The Side menu provides the end user access to system controls. To open the Side menu, swipe the screen from the right side of the screen toward the center, and tap the desired menu option.

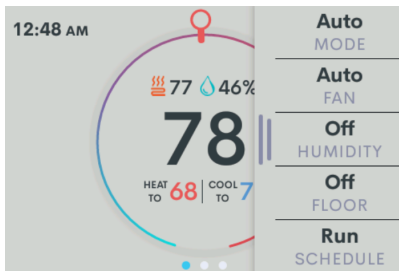

The Side menu options shown by default are MODE, FAN, and HUMIDITY. FLOOR appears as a menu item if Radiant Floor is set to **Floor Warming** or **Floor Warm/Space Heat**.

**NOTE:** To exit a screen, swipe down or make a selection.

# System Modes

Select **Mode** and then the desired Mode for the configured system.

## For One and Two Stage Heat/Cool and Dual Fuel Heat Pump

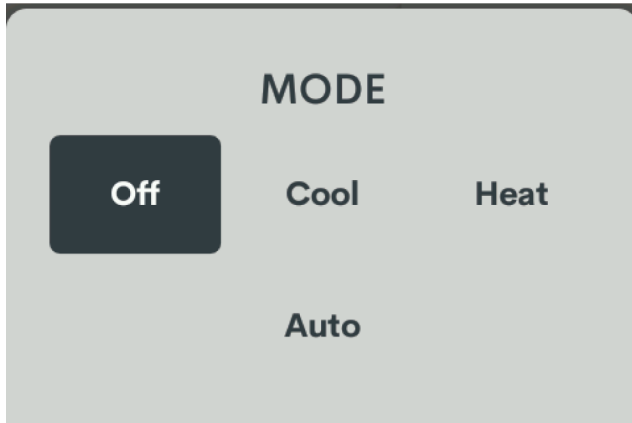

## Heat Pump w/ Aux

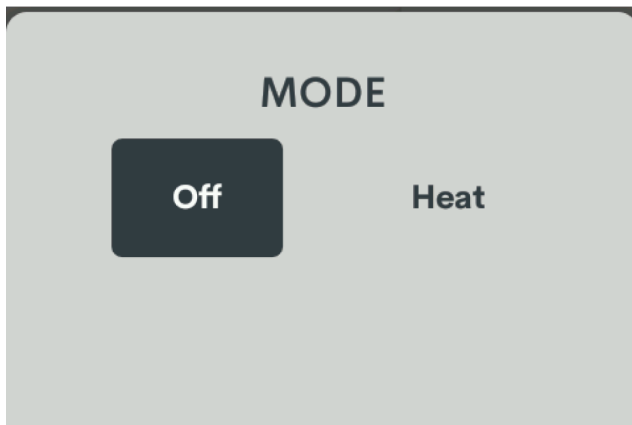
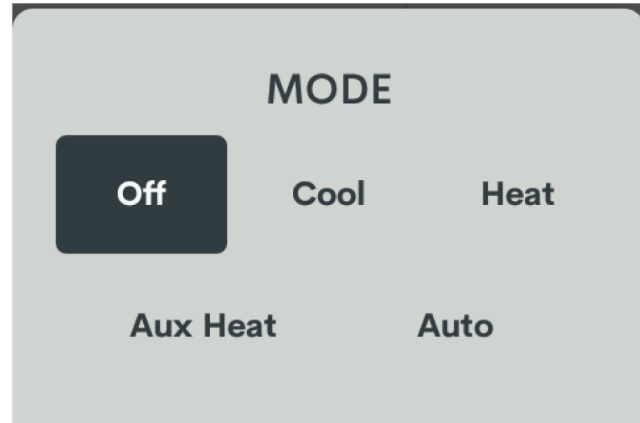

## Heat Only

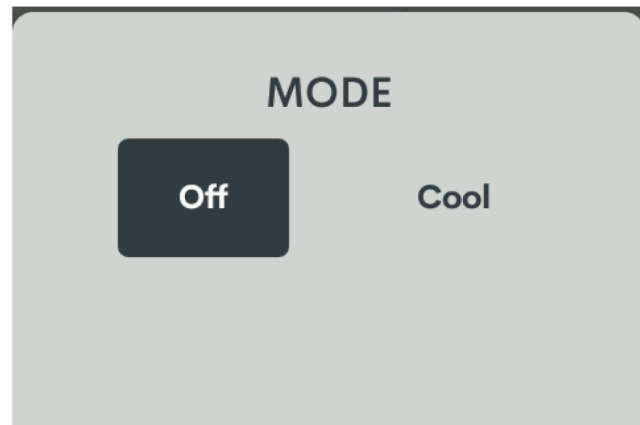

## Cool Only

- **Cool:** To control the cooling system.
- **Heat:** To control the heating system.
- **Aux Heat:** (only for Heat Pump systems) To shut off the Heat Pump and force heat only mode using the Auxiliary Heat stages.
- **Auto:** (if Auto mode is configured) To allow the thermostat to automatically switch between heating and cooling systems using a Single Setpoint or Dual Setpoints depending on the User Controls settings. Auto only appears if Auto mode is configured in User Controls.
- **Off:** To stop the thermostat from controlling the heating and cooling systems.

# Fan Modes

Select **FAN** and then the desired mode for the Fan operation.

## Fan Selections for Systems with One Fan Speed

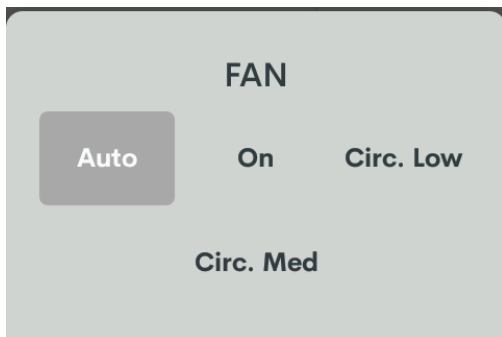



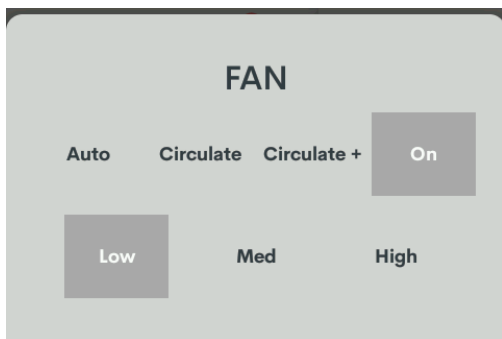



## Fan Selections for Systems with Multiple Fan Speeds



- **Auto:** Turns on the fan automatically when the system is operating. Select **Auto** to enable cool or heat calls and Fan In Heat settings to turn on the fan automatically.
- **On:** Turns on the fan. If multiple fan speeds are available, select a **Low**, **Med**, or **High** fan speed.
- **Circulate** or **Circ. Low:** The fan will run the same as in **Auto** mode. Additionally this mode will ensure that the fan runs at a minimum duty cycle to circulate air in the space. If the Auto Fan calls satisfy the minimum duty cycle, this operating mode wont result in any additional fan calls. If multiple fan speeds are available, the fan operates at the selected fan speed.
- **Circulate +** or **Circ. Med:** This mode is similar to **Circulate** and **Circ. Low** mode but with a higher duty cycle for the fan calls to circulate air more frequently in the space.

The fan status is indicated on the main UI of the thermostat using one of these icons:

- : Fan low
- : Fan medium
- : Fan high
- : Circulate mode with fan low
- : Circulate mode with fan medium
- : Circulate mode with fan high

## Humidity Control

Select **HUMIDITY** to turn the Humidistat on or off. Either Humidify or Dehum (dehumidify) will show depending on whether Humidification or Dehumidification is set in Humidistat Setup. If **Humidistat Setup** is set to **Off** in the Installer Settings, the humidity controls will not be displayed. To show or hide HUMIDITY in the Side menu, refer to [End User Access on page 181](#).

## Radiant Floor Control

Select **FLOOR** to turn the Floor Warming system on or off. FLOOR only appears if Radiant Floor is set to Floor Warming or Floor Warm/Space Heat. If **Radiant Type** is set to **None** in the Installer Settings, the floor controls will not be displayed. To show or hide FLOOR in the Side menu, refer to [End User Access on page 181](#).

## Schedule Control

Select **SCHEDULE** to switch between Run and Hold (pause) a control system schedule. If the thermostat is not connected to a control system, SCHEDULE will not be displayed.

# Brightness

**NOTE:** Set the thermostat's autodim curve by adjusting the slider for the desired brightness in both a dim room condition and a full dark condition.

- Adjusting in a dim room ensures that the thermostat's local sensor is not saturated and accurately adjusts the dim curve.
- Adjusting in a fully dark room while the thermostat is in night mode sets the minimum brightness for the thermostat.

To adjust the brightness:

1. Swipe up from the bottom of the screen.
2. Drag the slider to the left to dim or right to brighten the screen.

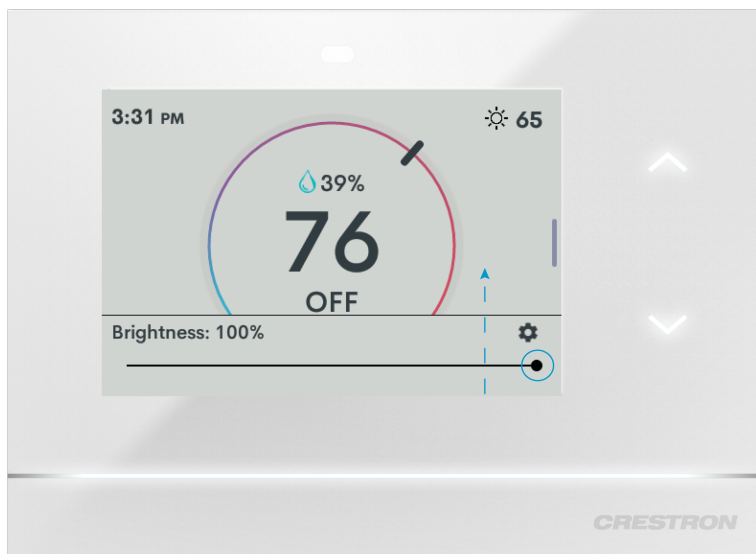

# User Settings

To open the SETTINGS screen:

1. Swipe up from the bottom of the screen.
2. Tap the gear icon.

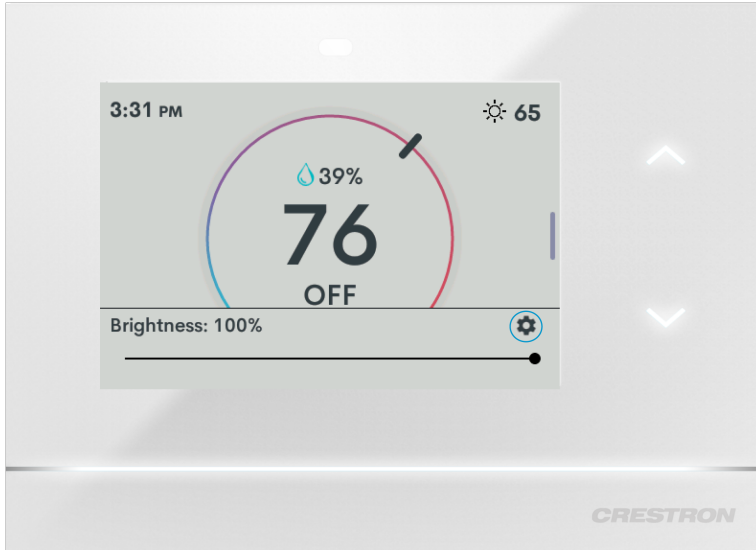

3. Tap **Display** or **Wireless Network** to adjust the settings. These are easy-to-access settings for the end user. Refer to [Display on page 175](#) and [Wireless Network on page 177](#) for details.

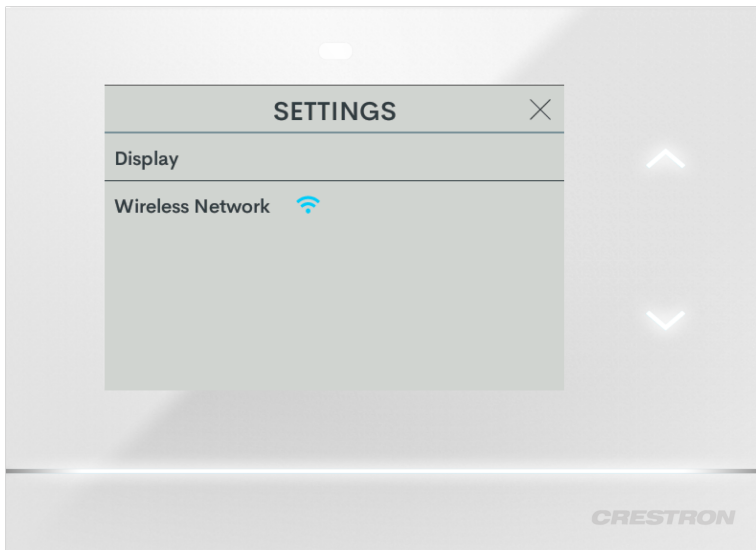

# Display

Use the **DISPLAY** screens to adjust the display and backlight settings for both day and night themes. The thermostat's local sensor determines day and night based on the ambient light level. When the sensor detects low light levels, the thermostat switches to the night theme.

## NOTES:

- The Help icon (  ) provides descriptions of settings throughout the setup screens. Tap the Help icon to open the Help window. To close the Help window, tap **Done**.
- Tap the orange arrow in the upper right-hand corner to move to the next screen.
- To close a setting screen, click the X or swipe the screen top to bottom.

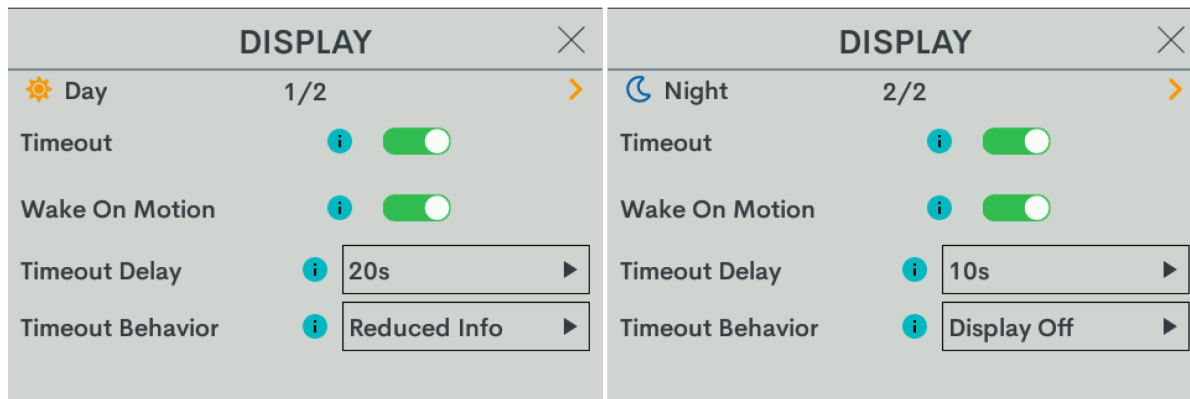

Day and Night Display settings:

- **Timeout:** Tap to enable or disable timeout settings for the Display, Lightbar, and capacitive buttons when there is no user interaction.
- **Wake On Motion:** Tap to enable or disable the Wake on Motion feature. Enable to wake the thermostat from timeout when motion or proximity to the sensor is detected.
- **Timeout Delay:** From the drop-down menu, select the amount of time the thermostat must not detect motion, proximity, or touch to time out.  
Drop-down menu timeout delay options: 5 seconds, 10 seconds, 20 seconds, 40 seconds, 1 minute, 5 minutes, 10 minutes, 20 minutes, 40 minutes, or 1 hour.

- **Timeout Behavior:** The desired behavior for when the thermostat times out. Select **Reduced Info**, **Display Off**, and **All Off**.
  - **Reduced Info:** Removes extra items on the screen for a clean look.

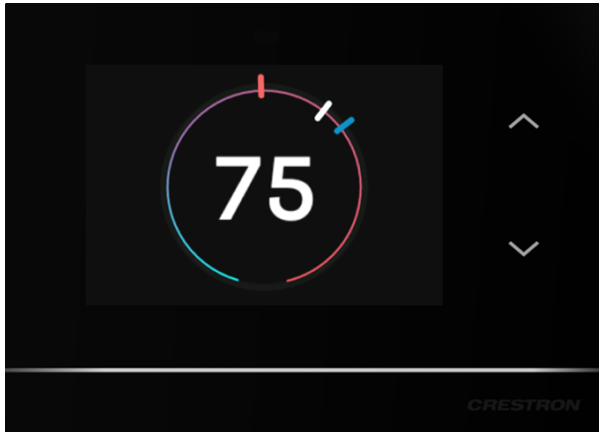

- **Display Off:** Turns off the screen and the Up/Down buttons. The lightbar indicates

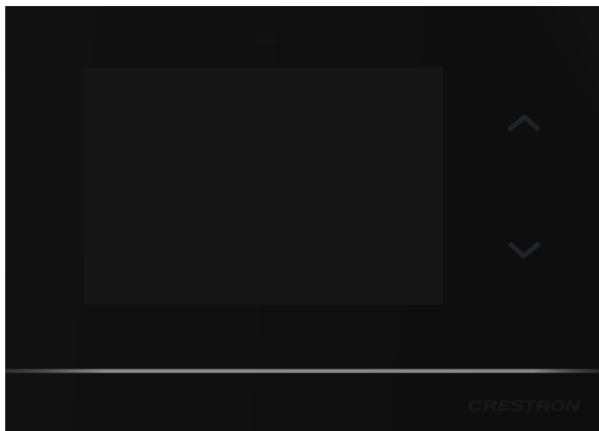

- **All Off:** Turns off the screen, the Up/Down buttons, and the lightbar.

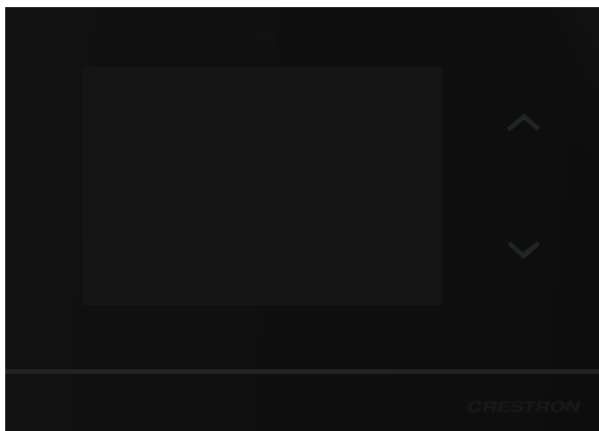

# Wireless Network

The WIRELESS NETWORK provides quick access to limited network settings and information. For more wireless network settings, refer to [Installer Settings on page 179](#).

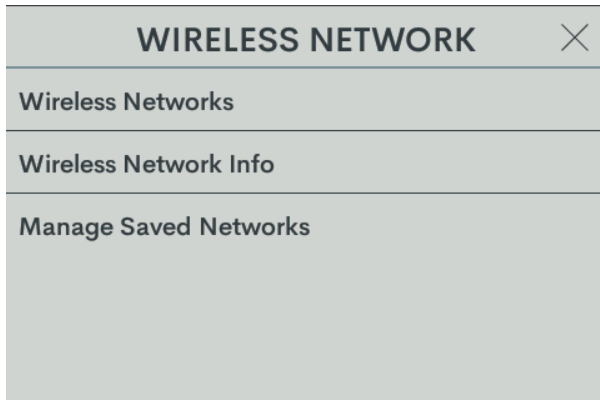

## Wireless Networks

Use the **Wireless Networks** screen to display the available networks.

To update the list of networks, select **Refresh**.

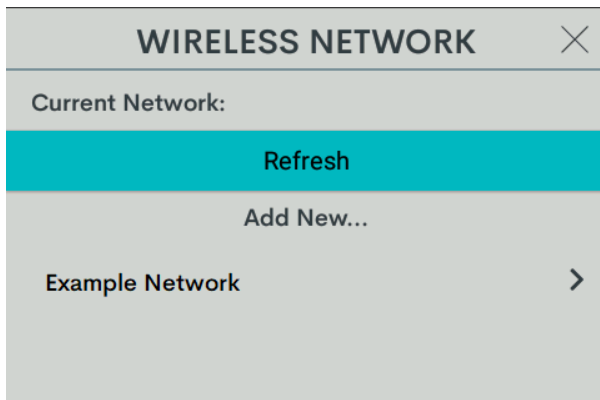

To join a wireless network:

1. Select a wireless network.
2. Enter the Password. Tap the eye icon to show or hide the password.
3. Select **Join Network**.

To add a network that is not listed:

1. Select **Add New**.
2. Enter the **Network Name** and **Password** for the wireless network.
3. Select the Network Security Type: WEP, WEP-128, WPA AES, WPA TKIP, WPA2 AES, or WPA2 TKIP.

4. Tap **Join Network**.



## Wireless Network Info

Use the **Wireless Network Info** screen to display the following data: MAC Address, IP Address, Subnet Mask, Def Router, Primary DNS, Secondary DNS, Hostname, Domain, RSSI, and LQI.

## Manage Saved Networks

Use the **Manage Saved Networks** to display and edit the saved networks.

Tap on a listed network to set it as the preferred network, change the password, or delete the network.

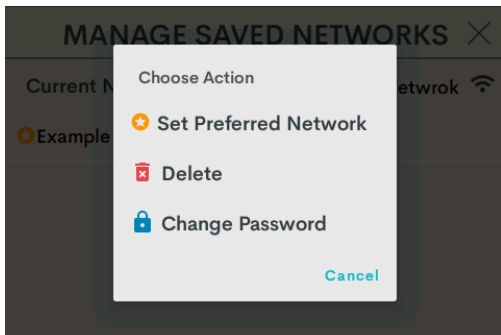

# Installer Settings

Use the Installer Settings screens to configure the thermostat.

To open the INSTALLER SETTINGS screen:

1. Swipe up from the bottom of the screen and then tap the gear icon.

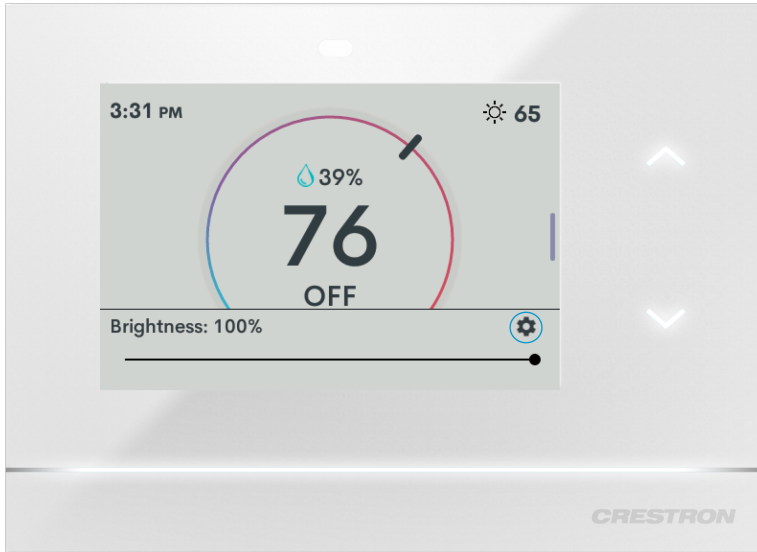

2. Use the Up/Down buttons to enter the Installer Settings button sequence. Tap the **Up** button two times and then the **Down** button two times (**Up, Up, Down, Down**).

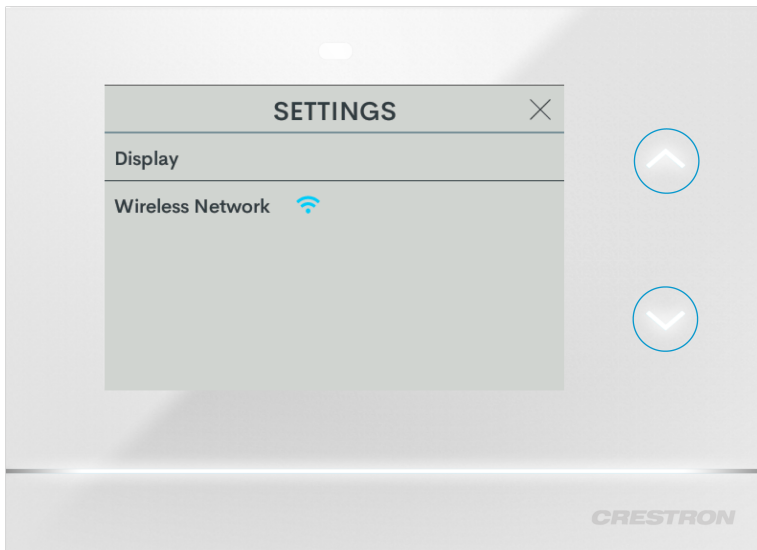

3. The **INSTALLER SETTINGS** screen displays.

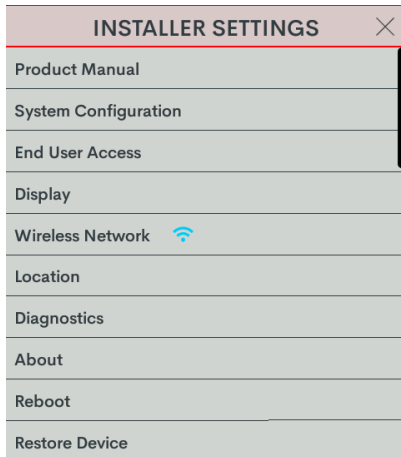

## Product Manual

Select **PRODUCT MANUAL** to display a QR code that opens this Product Manual. Scan the QR code with a smart device.



# System Configuration

Use the System Configuration screen to configure the System Type, System Performance, Radiant Floor, User Controls, Humidistat, and Sensors to work with the connected HVAC system. For details, refer to [Configuration on page 46](#).

To configure a specific system type, refer to these sections of the [Configuration on page 46](#) section.

- [Heat/Cool, 1 or 2 Stages, Forced Air or Radiant on page 52](#)
- [Heat Pump, 1 or 2 Stages, Aux Heat or Dual Fuel on page 59](#)
- [Radiant Floor Only \(Floor Warming\) on page 67](#)
- [Radiant Floor Only \(Space Heating\) on page 73](#)
- [Radiant Floor Only \(Floor Warming/Space Heating\) on page 79](#)
- [2 Stage Heat \(Stage 1 Radiant Floor\)/1 Stage Cool on page 85](#)
- [2 Stage Heat \(Stage 1 Radiant Floor\)/1 Stage Cool Heat Pump with 1 Stage Aux Heat on page 95](#)
- [2 Stage Heat \(Stage 1 Radiant Floor Warming/Space Heating\)/1 Stage Cool on page 106](#)
- [2 Stage Heat \(Stage 1 Radiant Floor Warming/Space Heating\)/1 Stage Cool Heat Pump with 1 Stage Aux Heat on page 116](#)
- [4-Pipe FCU 1 Stage Heat/Cool, with optional Radiant Floor Stage, optional Floor Warming, and optional Aux Heat Stage on page 155](#)
- [2-Pipe FCU with 1 or 2 Stage Heat/Cool, with optional Radiant Floor Stage, optional Floor Warming, and optional Aux Heat Stage on page 127](#)
- [2-Pipe FCU with 1 or 2 Stage Heat, with optional Radiant Floor Stage, optional Floor Warming, and optional Aux Heat Stage on page 136](#)
- [2-Pipe FCU with 1 or 2 Stage Cool, with optional Radiant Floor Stage, optional Floor Warming, and optional Aux Heat Stage on page 144](#)

## End User Access

Use the **END USER ACCESS** screen to modify the controls that are displayed on the user interface in the Side menu. The **MODE** control cannot be hidden.

To hide controls for the Fan, Humidistat, or Radiant Floor, turn off the toggle next to **Fan Control**, **Humidistat Control**, or **Radiant Floor Control**.

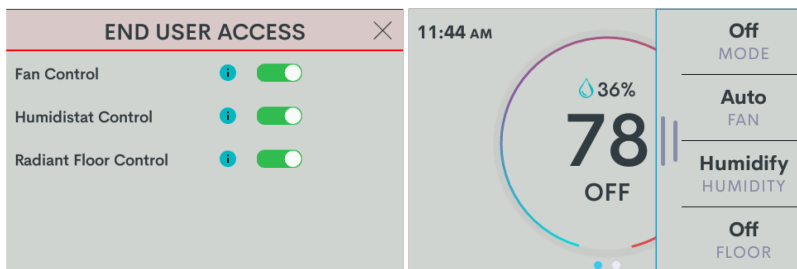

## Display

Provides the same settings as the end user Display screen. For details, refer to [Display on page 175](#).

# Wireless Network

Provides the same settings as the end user Wireless Network screen but also includes IP Settings and IP Table Setup. For details, refer to [Wireless Network on page 177](#).

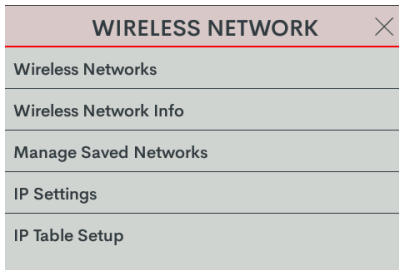

## IP Settings

Use the **IP Settings** screen to switch between DHCP and static IP, and manually set the host name and static IP settings.

When opening IP Settings, a warning appears:

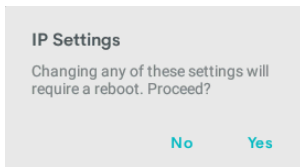

Tap **No** to go back to WIRELESS NETWORK. Tap **Yes** to continue to IP SETTINGS. When continuing to edit the IP Setting, consider the following:

- Tap on the editable fields, such as Hostname, to initiate the keyboard.
- Disable the DHCP toggle to edit the following settings: Static IP Address, Static IP Mask, Static Default Router, Static IP Primary DNS, and Static IP Secondary DNS.

**NOTE:** Changing any of these settings will prompt a reboot warning in the INSTALLER SETTINGS. The changes will not go into effect until the thermostat reboots.

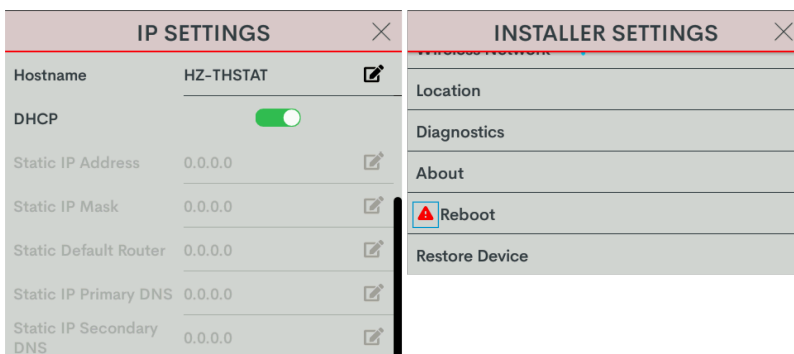

## IP Table Setup

IP Table Setup allows the thermostat to be connected to a control system. An IP Table is a lookup table used by Crestron Ethernet devices to map between IP IDs and IP addresses. Refer to the control system documentation for details.

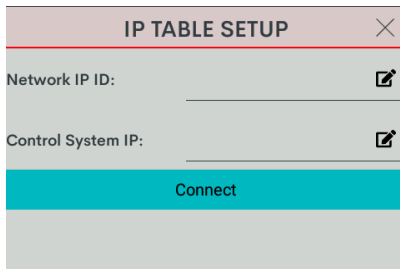

IP TABLE SETUP		✕
Network IP ID:	<input type="text"/>	✎
Control System IP:	<input type="text"/>	✎
Connect		

- **Network IP ID:** Match the Network IP ID stated in control system's program.
- **Control System:** Set the IP to the control system's IP address or Hostname.

**NOTE:** When used with Crestron Home® OS this section will be auto populated when added to the Crestron Home control processor.

## Location

The thermostat utilizes the data entered in the **LOCATION** screen to provide accurate weather information on the home screen.

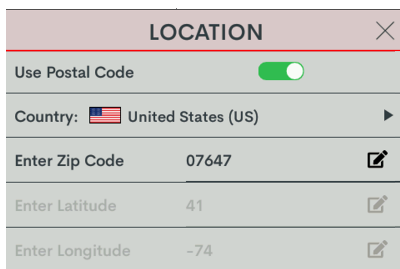

LOCATION		✕
Use Postal Code	<input checked="" type="checkbox"/>	
Country:	United States (US)	▶
Enter Zip Code	07647	✎
Enter Latitude	41	✎
Enter Longitude	-74	✎

**NOTE:** United States residents only can enter the Postal Code. Residents outside the United States can enter the latitude and longitude.

# Diagnostics

Use **DIAGNOSTICS** to test the HVAC system calls, review call log summaries, sensor log summaries, or review system settings.

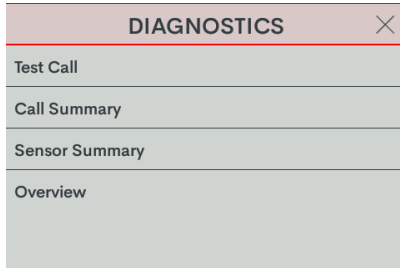

## Test Call

Use the **Test Call** screen to view the test call options. The system type and configured settings determine the available test call options.

Tap the toggle next the desired option to perform a test call.



## Call Summary

Use the **Call Summary** screen to view HVAC Call Frequencies, Min/Max/Average setpoint history, and Min/Max/Average sensor history. Information can be filtered by Day, Week, or Month and specific days, weeks, or months. For a more detailed sensor summary, refer to the Sensor Summary screen.

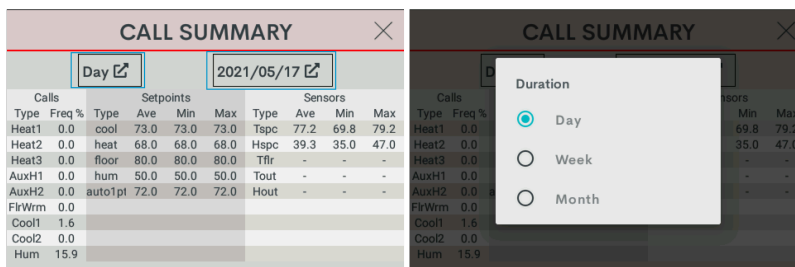

## Sensor Summary

Use the **Sensor Summary** screen to view details about the local and remote sensors. As with Min/Max/Average temperature/humidity and error counts, information can be filtered by Day, Week, or Month and specific days, weeks, or months.

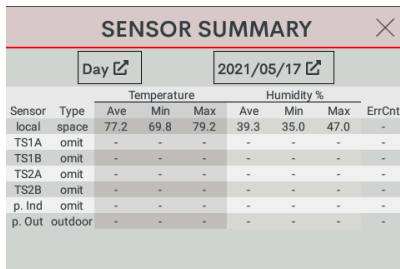

The screenshot shows the 'SENSOR SUMMARY' screen with a close button (X) in the top right. Below the title bar, there are two input fields: 'Day' and '2021/05/17'. The main content is a table with columns for Sensor, Type, Temperature (Ave, Min, Max), Humidity % (Ave, Min, Max), and ErrCnt. The data is as follows:

Sensor	Type	Temperature			Humidity %			ErrCnt
		Ave	Min	Max	Ave	Min	Max	
local	space	77.2	69.8	79.2	39.3	35.0	47.0	-
TS1A	omit	-	-	-	-	-	-	-
TS1B	omit	-	-	-	-	-	-	-
TS2A	omit	-	-	-	-	-	-	-
TS2B	omit	-	-	-	-	-	-	-
p.Ind	omit	-	-	-	-	-	-	-
p.Out	outdoor	-	-	-	-	-	-	-

## System Overview

Use the **System Overview** screen to view a summary of the system configuration.

## About

To display version information for the device, select **About**.

## Reboot

To restart the thermostat, select **Reboot** and then **Yes**.

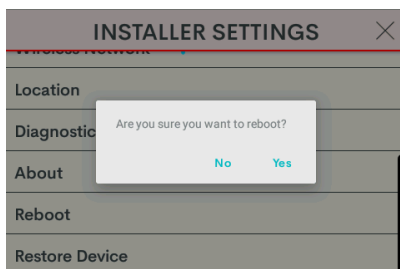

## Restore Device

To restore the thermostat to factory settings, select **Restore Device** and then **Yes**.

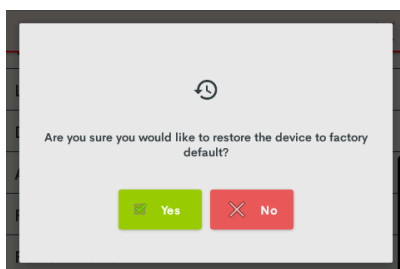

# Glossary

The following are system type and radiant floor definitions.

## System Type Definitions

### One or Two Stage Heat/Cool Systems

Unlike traditional furnaces that turn on and run at full capacity with each demand for heating, 2-stage furnaces operate like two separate furnaces. The unit begins to run in its first stage, and operates at a fraction of its heating capacity. This reduced capacity is sufficient on mild winter days. On very cold days, the furnace adjusts to full capacity (second stage) to meet the demand for heat.

- **Heat/Cool:** Separate heat and cool systems. Heat calls are on W/W2 and Cool calls are on Y/Y2.
- **Heat Only:** Heat-only systems. Heat calls are on W/W2.
- **Cool Only:** Cool-only systems. Cool calls are on Y/Y2.

### Heat Pump Systems

A heat pump extracts available heat from one area and transfers it to another. Even cold air contains some heat, and heat pumps can extract heat from the outside air on a cold day and transfer it indoors to maintain a comfortable temperature. A heat pump also works in reverse during the summer, extracting heat from indoors and transferring it outdoors.

- **Aux (Auxiliary) Heat:** When the a heat pump can no longer efficiently transfer heat from the outside air, the thermostat automatically turns on a secondary heat source, such as electric resistive heat.
- **Dual Fuel:** A Dual Fuel Heat pump system combines an energy efficient air source heat pump with a new or existing oil, gas or propane furnace. The furnace runs in place of the heat pump in cold weather.

### Fan Coil Unit (FCU)

A fan coil unit (FCU) uses a fan to move indoor air over a coil (heat exchanger) to heat or cool an area. The temperature is regulated by controlling the fan speed and turning on or off the flow of water or refrigerant through the coil. Three separate relays are used for adjusting the fan speed between low, medium, or high.

4-Pipe FCU systems have separate input and output pipes for heat and cool.

2-Pipe FCU systems share input and output pipes for heat/cool operation or may be limited to heat only or cool only operation. 2-Pipe FCU Heat/Cool systems can either have a changeover temperature sensor to detect the current operating mode of the system or can rely on an end user to select if the system is currently in heat or cool operating modes.

# Radiant Floor Heating Definitions

Radiant floor heating works from the ground up. The heating components are installed below the floor or are embedded in a concrete slab. Heat radiates from the floor to warm the space above.

- **Floor Warming:** Operates the radiant floor heat to maintain a particular floor temperature. Floor Warming can be turned on and off by the end user. Radiant floor heat is maintained at the radiant floor setpoint temperature value. Connection to the radiant floor output relay is terminal W2.
- **Space Heating:** Maintains a particular air temperature using the radiant floor heat to heat the space. Does not heat over the radiant floor maximum temperature even if this results in the space being under-heated. Connection to the radiant floor output relay is terminal W2.
- **Floor Warming/Space Heating:** Performs the same operation as Space Heating and also keeps the slab at least as warm as slab setpoint when Floor Warming is set to Heat. Floor Warming can be turned on and off by the end user. This may result in the space being overheated to maintain the radiant floor minimum temperature. Connection to the radiant floor output relay is terminal W2.

The HZ-THSTAT offers many Radiant Floor configurations, including, but not limited to, the following options:

- **2 Stage Heat (Stage 1 Radiant Floor)/1 Stage Cool:** Maintains the air temperature using the radiant floor for heat, up to the radiant floor maximum. Augments the air heating by using a second stage of heat (generally a forced air system). Allows the second stage to operate by itself should the radiant floor reach its maximum temperature and shut off. Cools the space with cooling call. Intended for heat-cool type forced air systems, with relay output connections to terminal W2 for radiant floor heat, terminal W1 for second stage heat, and terminal Y1 for cooling.
- **2 Stage Heat (Stage 1 Radiant Floor)/1 Stage Cool Heat Pump with 1 Stage Aux Heat:** Performs the same operation as 2 Stage Heat (Stage 1 Radiant Floor)/1 Stage Cool but for a Heat pump second stage. Relay output connections are terminal W2 for radiant floor heat, with heat pump-type connections on terminals Y1/O/G for cooling and heating calls. Aux heat is on terminal W1
- **2 Stage Heat (Stage 1 Radiant Floor Warming/Space Heating)/1 Stage Cool:** Combines the operation of a space heating/cooling thermostat with a floor-warming thermostat. Maintains the radiant floor heat at radiant floor setpoint, and maintains the space at the heat, cool, or auto setpoints. Systems effectively operate independently. Heat/Cool/Auto/Off sets the space control modes, and Floor Warming HEAT/OFF sets the slab mode. Intended for heat-cool style systems, with radiant floor connection on terminal W2, space heat on terminal W1, and space cool on terminal Y1.
- **2 Stage Heat (Stage 1 Radiant Floor Warming/Space Heating)/1 Stage Cool Heat Pump with 1 Stage Aux Heat:** Performs the same operations as 2 Stage Heat (Stage 1 Radiant Floor Warming/Space Heating)/1 Stage Cool but for heat pump space systems, with radiant floor heat on terminal W2, and space heat/cool on terminals Y1/O/G. Aux heat is on terminal W1.
- **2 Stage Heat (Stage 1 Radiant Floor Warming/Space Heating)/ 1 Stage Cool 4-Pipe FCU with 1 Stage Aux Heat:** Performs the same operations as 2 Stage Heat (Stage 1 Radiant Floor Warming/Space Heating)/1 Stage Cool but for 4-Pipe FCU systems, with radiant floor heat on terminal W2, space heat/cool on terminals Y2/Y, High/Med/Low Fan speeds on O/B/G, and Aux heat is on terminal W.

- **1 Stage Heat (Radiant Floor)/2 Stage Cool 2-Pipe FCU Cool Only:** Maintains the air temperature using the radiant floor for heat, up to the radiant floor maximum. Cools the space with cooling FCU call. Radiant floor heat on terminal W2, space cool on terminals Y/Y2, and High/Med/Low Fan speeds on O/B/G.

This page is intentionally left blank.

