

UCA-B70-MIC-TTMK

Tabletop Mounting Kit for Crestron Videobar 70 Extension Microphone Pods



The Crestron [UCA-B70-MIC-TTMK](#) Tabletop Mounting Kit for Crestron Videobar 70 Extension Microphone Pods is a tabletop mounting option for the [UCA-B70-MIC](#) and [UCA-B70-MIC-AUX](#). The UCA-B70-MIC-TTMK includes a threaded tube, mounting plate, and an enclosure to mount an Extension Microphone Pod to the surface.

The mounting kit can be installed on any flat, level surface with a minimum thickness of 3/4 in. (19 mm) up to a maximum thickness of 1-1/2 in. (38 mm). The table-mounted microphone pod protrudes 1 in. (25 mm) from the surface after installation. Cables are routed through the center of the threaded tube, passing beneath the mounting surface for a completely hidden appearance.

Specifications

Construction

Material	Metal, plastic (bulkhead nut)
Mounting	Mounts into a 2 in. (51 mm) diameter hole in a table (or similar flat surface); 3/4 in. (19 mm) minimum surface thickness; 1-1/2 in. (38 mm) maximum surface thickness

Dimensions

Height	4.38 in. (111 mm)
Width	6.40 in. (162 mm)
Depth	7.28 in. (185 mm)

Weight

8 oz (230 g)

Model

UCA-B70-MIC-TTMK

Tabletop Mounting Kit for Crestron Videobar 70 Extension Microphone Pods

This product may be purchased from select authorized Crestron dealers and distributors. To find a dealer or distributor, please contact the Crestron sales representative for your area. A list of sales representatives is available online at www.crestron.com/How-To-Buy/Find-a-Representative or contact us for additional information by visiting www.crestron.com/contact/our-locations for your local contact.

The original language version of this document is U.S. English. All other languages are a translation of the original document.

The product warranty can be found at www.crestron.com/warranty.

The specific patents that cover Crestron products are listed online at www.crestron.com/legal/patents.

Certain Crestron products collect information that may include personal data. For further details regarding those Crestron products that collect, process, and transmit information directly to Crestron via the Internet, please refer to the Crestron Privacy Statement Regarding Internet Data Collection, located at <http://www.crestron.com/legal-data-collection-privacy>.

Certain Crestron products contain open source software. For specific information, please visit www.crestron.com/opensource.

Crestron and the Crestron logo are either trademarks or registered trademarks of Crestron Electronics, Inc. in the United States and/or other countries. Other trademarks, registered trademarks, and trade names may be used in this document to refer to either the entities claiming the marks and names or their products. Crestron disclaims any proprietary interest in the marks and names of others. Crestron is not responsible for errors in typography or photography.

Specifications are subject to change without notice.

©2026 Crestron Electronics, Inc.

Rev 05/12/26

UCA-B70-MIC-TTMK

Tabletop Mounting Kit for Crestron Videobar 70 Extension Microphone Pods

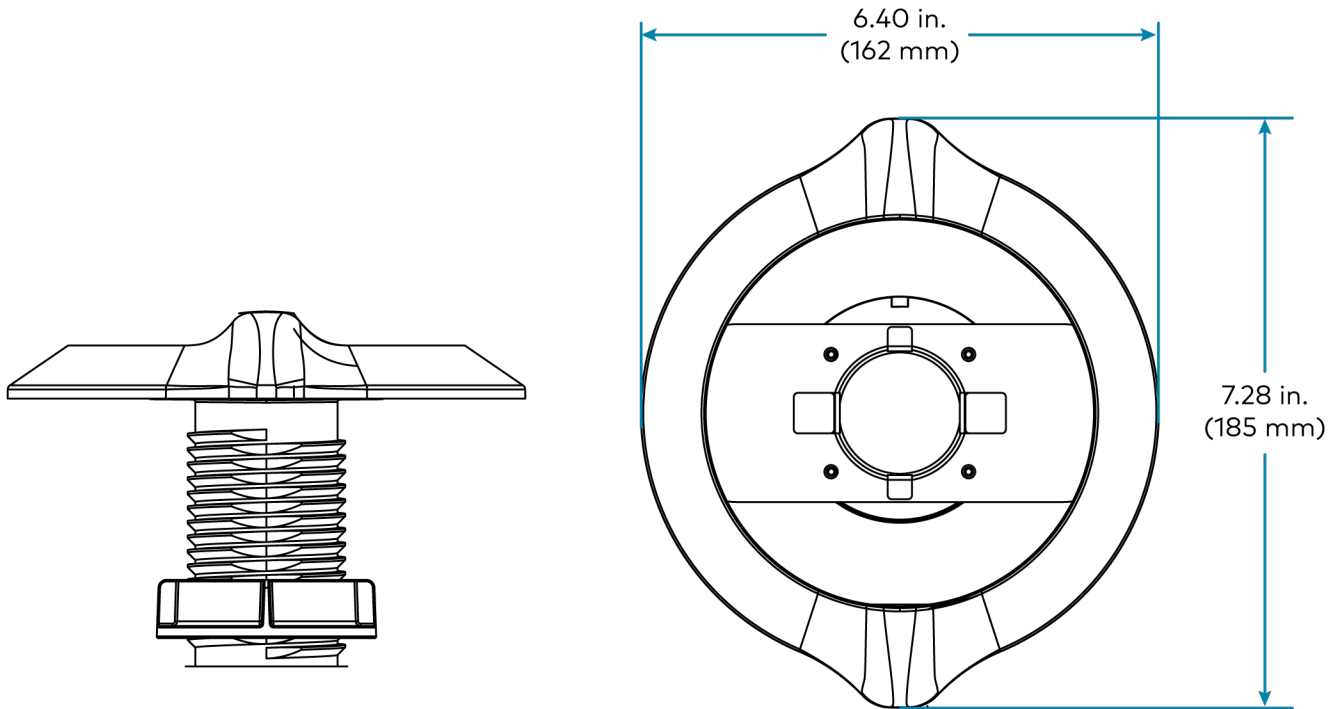

UCA-B70-MIC-TTMK

Tabletop Mounting Kit for Crestron Videobar 70 Extension Microphone Pods

