

Crestron **CHV-TSTATEX-FCU**
infiNET EX[®] Thermostat (Fan Coil Unit)
Operations & Installation Guide



This document was prepared and written by the Technical Documentation department at:



Regulatory Compliance

As the date of manufacture, the CHV-TSTATEX-FCU has been tested and found to comply with specifications for CE marking and standards per EMC and Radiocommunications Compliance Labelling.



Federal Communications Commission (FCC) Compliance Statement

This device complies with part 15 of the FCC Rules. Operation is subject to the following conditions: (1) This device may not cause harmful interference and (2) this device must accept any interference received, including interference that may cause undesired operation.

CAUTION: Changes or modifications not expressly approved by the manufacturer responsible for compliance could void the user's authority to operate the equipment.

NOTE: This equipment has been tested and found to comply with the limits for a Class B digital device, pursuant to part 15 of the FCC Rules. These limits are designed to provide reasonable protection against harmful interference in a residential installation. This equipment generates, uses and can radiate radio frequency energy and, if not installed and used in accordance with the instructions, may cause harmful interference to radio communications. However, there is no guarantee that interference will not occur in a particular installation. If this equipment does cause harmful interference to radio or television reception, which can be determined by turning the equipment off and on, the user is encouraged to try to correct the interference by one or more of the following measures:

- Reorient or relocate the receiving antenna
- Increase the separation between the equipment and receiver
- Connect the equipment into an outlet on a circuit different from that to which the receiver is connected
- Consult the dealer or an experienced radio/TV technician for help

Industry Canada (IC) Compliance Statement

1. This Class B digital apparatus complies with Canadian ICES-003.
2. Cet appareil numérique de la classe B est conforme à la norme NMB-003 du Canada

To satisfy RF exposure requirements, this device and its antenna must operate with a separation distance of at least 20 centimeters from all persons and must not be collocated or operating in conjunction with any other antenna or transmitter.

The specific patents that cover Crestron products are listed at www.crestronpatents.com.

Crestron, the Crestron logo, 3-Series Control System, Cresnet, Crestron Toolbox, D3 Pro, infiNET EX and SystemBuilder are either trademarks or registered trademarks of Crestron Electronics, Inc. in the United States and other countries. Windows is either a trademark or registered trademark of Microsoft Corporation in the United States and/or other countries. Other trademarks and trade names may be used in this Document to refer to either the entities claiming the marks and names or their products. Crestron disclaims any proprietary interest in the marks and names of others.

©2012 Crestron Electronics, Inc.

Contents

infiNET EX[®] Thermostat (Fan Coil Unit): CHV-TSTATEX-FCU	1
Introduction	1
Features and Functions	1
Specifications	3
Physical Description	5
Setup	9
Identity Code	9
Supplied Hardware	9
Installation	9
DIP Switch Setup	11
Wiring the CHV-TSTATEX-FCU to the HVAC System	12
Basic Setup	16
Basic Thermostat Setup	16
Joining an infiNET EX Network	16
Leaving an infiNET EX Network	17
Advanced Setup	18
Setup Mode	18
Setup Mode Parameters/Functions	19
Verifying Communication Status	21
Self-Test Results	22
Operation	23
System Mode	23
Fan	24
Setpoints	24
Hold	25
Remote Operation	25
LCD Display	26
Programming Software	28
Earliest Version Software Requirements for the PC	28
Programming with Crestron SystemBuilder	28
Programming with D3 Pro	28
Programming with SIMPL Windows	29
Uploading and Upgrading	31
Establishing Communication	31
Programs and Firmware	32
Program Checks	32
Problem Solving	33
Troubleshooting	33
Reference Documents	36
Further Inquiries	36
Future Updates	36
Glossary	37
Return and Warranty Policies	38
Merchandise Returns / Repair Service	38
Crestron Limited Warranty	38

infiNET EX[®] Thermostat (Fan Coil Unit): CHV-TSTATEX-FCU

Introduction

The CHV-TSTATEX-FCU is a wireless thermostat featuring infiNET EX[®] technology. The CHV-TSTATEX-FCU installs just like a conventional thermostat because no extra wires are needed to connect to the control system. Although functional as a standalone thermostat, the CHV-TSTATEX-FCU delivers enhanced functionality as part of a complete Crestron[®] automation system. Integrating HVAC with a Crestron system can help lower energy bills and increase user friendliness.

The CHV-TSTATEX-FCU is designed for fan coil unit HVAC systems. The large backlit LCD display provides a clear view of temperature, set point, system mode, fan mode, system status, and setup functions. Climate control features include separate heating and cooling set points, and adjustable anticipators to prevent overshooting the desired temperature. Continuous fan operation can be selected when needed for increased circulation.

Features and Functions

- Wall mount heat/cool thermostat for fan coil unit HVAC systems
- Crestron system integration via infiNET EX wireless network
- Saves on energy costs with advanced programming abilities
- Supports two remote temperature sensors
- *Fail-safe* mode allows operation in event of control system failure
- Backlit LCD display
- Fan coil unit control*
- Available in white, black, or almond

* Four pipe fan coil units are supported.

Fan Coil Unit Support

The CHV-TSTATEX-FCU model of the infiNET EX thermostat provides the functionality of controlling fan coil units¹. Aesthetically identical to the base model, the CHV-TSTATEX-FCU has custom firmware, display programming and terminal labels designed for 3-speed fan applications. The CHV-TSTATEX-FCU supports on/off control of the valves and the fan in four pipe fan coil applications, eliminating the need for an additional device dedicated to controlling the fan coil unit itself.

infiNET EX Communications

Built on steadfast infiNET EX technology, infiNET EX is the new standard in 2-way wireless connectivity that can handle installations in even the most urban settings. The redundant nature of its mesh networking technology means that a command will never be missed, resulting in faultless operation - something that is of the utmost importance when it comes to HVAC control and home automation. The CHV-TSTATEX-FCU harnesses this cutting edge wireless connectivity which affords it a level of robustness and dependability above other solutions.

Automation System Integration

The wireless connection to the control system allows the functions of the CHV-TSTATEX-FCU to be controlled from touch screens, keypads, wireless remotes, computers, or even a mobile device. It supports unlimited flexibility for remote control, scheduling, and integration with other devices and systems. However, in the event that communication with the control system is disrupted for any reason, the CHV-TSTATEX-FCU will remain operable to control the HVAC system.

Easy Installation

System design and installation using infiNET EX thermostats could not be easier. Since no control wires are required, the CHV-TSTATEX-FCU can be installed just like any conventional thermostat.

To simplify installation, physical switches are provided for the most critical configuration options, including power settings and fan options. These settings allow HVAC contractors to install and test the thermostats prior to the appearance of a Crestron system integrator.

An infiNET EX gateway such as the CEN-RFGW-EX or MC3 (both sold separately) is needed for communications. Setting the ID of each device employs the same convention as Crestron's familiar TSID (touch-settable ID) method, and each device is programmable using Crestron SIMPL Windows, SystemBuilder™ or D3Pro[®] software just like any wired Cresnet[®] device. Even firmware updates are performed over the wireless network.

No further action is required to configure the infiNET EX network. Each device assigned to a common gateway automatically behaves as a wireless expander² for any other devices within range (approximately 150 feet (~46 meters) indoors), and additional expanders may be added if necessary. The infiNET EX gateway monitors each device on the network at all times, ignoring any other 2.4 GHz signals. It reconfigures the entire network automatically in response to new sources of interference and other changes in RF conditions.

1. Four pipe fan coil units are supported.
2. CHV-TSTATEX-FCU must be powered by a 24 volt source to enable repeater functionality.

Specifications

Specifications for the CHV-TSTATEX-FCU are listed in the following table.

CHV-TSTATEX-FCU Specifications

SPECIFICATION	DETAILS
Wireless	
RF Transceiver	2-way RF, 2.4 GHz ISM Channels 11-26 (2400 to 2483.6 MHz), IEEE 802.15.4 compliant
Range (typical)	150 ft (46 m) indoor, 250 ft (76 m) outdoor; Subject to site-specific conditions; range is increased by adding additional devices or CLW-RFEXP-EX wireless expander (sold separately)
Gateway	Requires a CEN-RFGW-EX RF gateway or MC3 3-Series Control System™ (both sold separately)
Display	Backlit LCD with two large 7-segment digits, two small 7-segment digits, 14 dedicated symbols; Displays ambient temperature, set point, system mode, fan setting, call activity, low battery, RF or control system communication errors, firmware download progress, setup parameter/function and value
Measurement Range	
Ambient Temperature	-10° to 110° F (-23° to 43° C)
Display Limits	-9° to 99° F (-9° to 43° C)
Temperature Tolerance	
Over Full Range	±1° F (±0.5° C)
At Room Temperatures	±1° F (+0.4/-0.2° C)
Setpoint Range	
Heat only setpoint	38° to 89° F (3° to 32° C)
Cool only setpoint	59° to 99° F (15° to 37° C)
Relay Rating	1 Amp @ 40 Volts DC or 24 Volts AC (nominal)
Environmental	
Temperature	-10° to 110° F (-23° to 43° C)
Humidity	10% to 90% RH (non-condensing)
Power Requirements	
24V	0.24 Watts (10 mA @ 24 Volts AC) supplied by heating or cooling system
Battery	Two AA batteries, estimated one year normal operation

(Continued on following page)

CHV-TSTATEX-FCU Specifications (Continued)

SPECIFICATION	DETAILS
Default RF ID	01
Minimum 2-Series Control System Update File ^{1,2}	Version 4.001.1012 or later
Minimum 3-Series Control System Update File ¹	Version 1.8.0 or later
Minimum CEN-RFGWEX Update File	Version 2.001.0037 or later
Housing	Injection molded plastic, surface mountable to the front of a horizontally oriented single-gang electrical box.
Dimensions	
Height	4.50 in (115 mm)
Width	5.53 in (141 mm)
Depth	1.03 in (26 mm)
Weight	7 oz (190 g)
Available Models	
CHV-TSTATEX-FCU-A-T	infiNET EX Thermostat, Fan Control Unit, Matte, Almond
CHV-TSTATEX-FCU-B-T	infiNET EX Thermostat, Fan Control Unit, Matte, Black
CHV-TSTATEX-FCU-W-T	infiNET EX Thermostat, Fan Control Unit, Matte, White
Available Accessories	
C2N-RTHS	Temperature and Humidity Sensor, Cresnet
CEN-RFGW-EX	infiNET EX Wireless Gateway
CHV-RTHS ³	Remote Temperature and Humidity Sensor
CHV-RTS	Remote Temperature Sensor
MC3	3-Series Control System

1. The latest software versions can be obtained from the Crestron Web site. Refer to the NOTE following these footnotes.
2. Crestron 2-Series control systems include the AV2 and PRO2. Consult the latest Crestron Product Catalog for a complete list of 2-Series control systems.
3. The humidity function will not be reported to the CHV-TSTATEX-FCU.

NOTE: Crestron software and any files on the website are for authorized Crestron dealers and Crestron Authorized Independent Programmers (CAIPs) only. New users may be required to register to obtain access to certain areas of the site (including the FTP site).

Physical Description

This section provides information on the connections, controls and indicators available on your CHV-TSTATEX-FCU.

CHV-TSTATEX-FCU Physical View

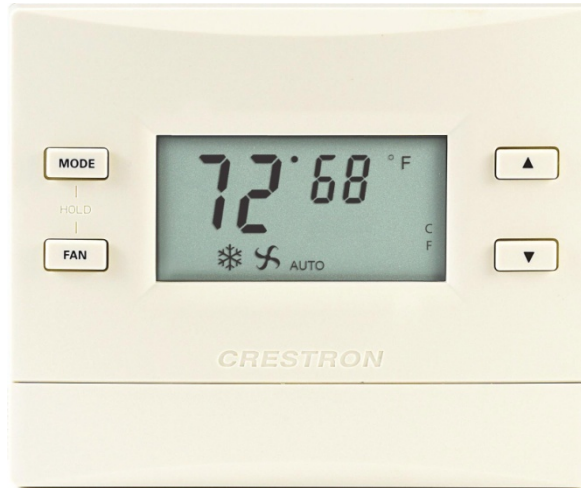

CHV-TSTATEX-FCU Overall Dimensions (Front and Side Views)

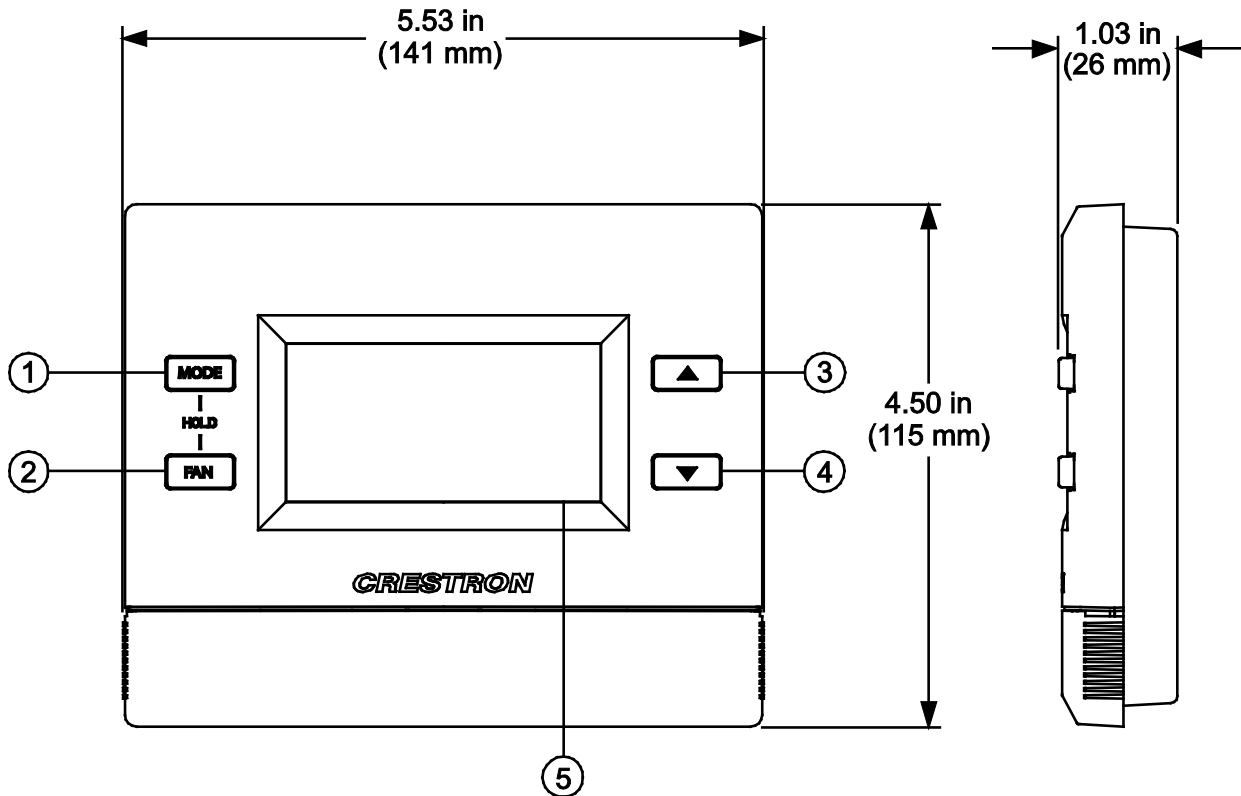

CHV-TSTATEX-FCU Overall Dimensions (Rear View)

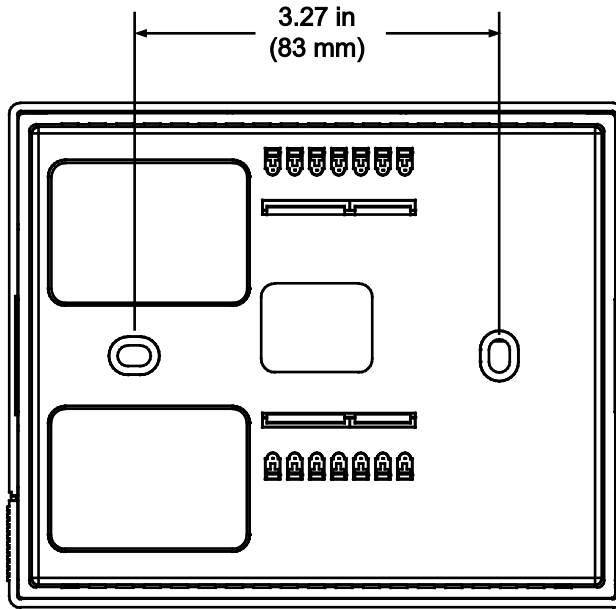

CHV-TSTATEX-FCU (Connection View, Front with Cover Removed)

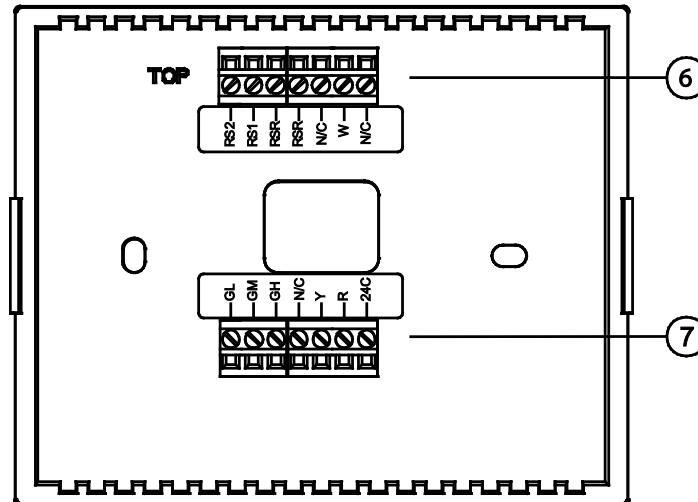

CHV-TSTATEX-FCU (DIP Switch and Power Switch View)

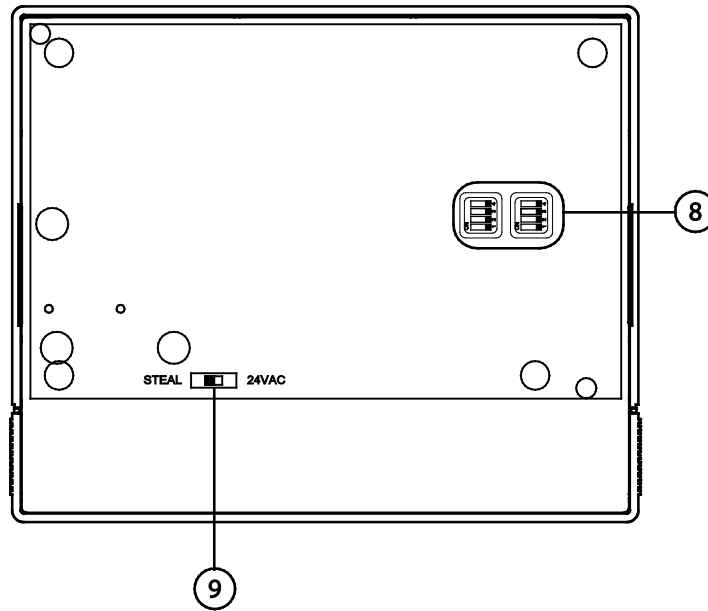

Connectors, Controls & Indicators

#	CONNECTORS, CONTROLS & INDICATORS	DESCRIPTION
1	MODE Button	Cycles through available system modes: <i>OFF, HEAT, AUTO</i> and <i>COOL</i>
2	FAN Button	Toggles fan setting between FAN AUTO and FAN ON
3	▲	Raises the setpoint
4	▼	Lowers the setpoint
5	LCD DISPLAY	Displays ambient temperature, set point, system mode, fan setting, call activity, low battery, RF or control system communication errors, setup parameter/function and value
6	HVAC	(4) Two-position terminal blocks RS2: Remote sensor (2) (outdoor) RS1: Remote sensor (1) (indoor) RSR: Remote sensor return RSR: Remote sensor return N/C: Unused W: Heat N/C: Unused

(Continued on following page)

Connectors, Controls & Indicators

#	CONNECTORS, CONTROLS & INDICATORS	DESCRIPTION
7	HVAC	(4) Two-position terminal blocks. GL: Fan low GM: Fan medium GH: Fan high N/C: Unused Y: Cool R: 24V return 24C: 24V supply
8	DIP Switches	(2) Four-bank two-position DIP switches used to configure device settings; Refer to "DIP Switch Setup" which starts on page 11 for details
9	Power Switch	(1) Two-position slide switch used to configure power settings; Refer to "DIP Switch Setup" which starts on page 11 for details

Setup

Identity Code

Every CHV-TSTATEX-FCU communicating via RF with a Crestron control system through a CEN-RFGW-EX wireless gateway or directly with an MC3 3-Series Control System requires a unique RF ID. The RF ID is a two-digit hexadecimal number that can range from 03 to FF. The RF ID of the unit, set using Crestron Toolbox[™], must match the RF ID specified in the SIMPL Windows program.

Supplied Hardware

The hardware supplied with the CHV-TSTATEX-FCU is listed in the following table.

Supplied Hardware for the CHV-TSTATEX-FCU

DESCRIPTION	PART NUMBER	QUANTITY
Screws, Zinc, Phillips, Pan Head, #06-32 x 1"	2007251	2
Batteries, AA, Alkaline	2001050	2

Installation

NOTE: Installers should have a strong working knowledge of HVAC systems.

The location of the thermostat can affect its performance and efficiency. Install the thermostat away from direct sunlight, drafts, doorways, skylights and windows. Also make sure the thermostat is conveniently located for control access and setup.

Thermostats should be mounted 60 inches (~1.6 meters) above the finished floor (HVAC industry standard). Do not mount on an exterior wall.

The following tools and hardware are required for installation.

- Standard single-gang electrical box, mounted horizontally (not supplied)
- Phillips screwdriver (not supplied)
- Two 1-inch pan head Phillips screws (included)
- Two AA batteries (included)

Use the following procedure to install the CHV-TSTATEX-FCU in a standard, single-gang electrical box (refer to illustration on the following page):

1. Turn HVAC system power **OFF**.
2. Separate thermostat front plate from back plate. You may need to exert force when removing the front plate.
3. Feed HVAC wiring from the electrical box through the hole in the center of the back plate so it can be connected to the proper terminals on the CHV-TSTATEX-FCU after the thermostat is mounted.
4. Make sure unit is correctly oriented and place it in the electrical box.

CAUTION: Excess wire pinched between the CHV-TSTATEX-FCU and electrical box could cause a short circuit. Make sure that all excess wire is completely inside the electrical box and not between the box and the CHV-TSTATEX-FCU.

NOTE: To ensure accurate temperature readings, avoid drafts in the back of the unit by plugging the wire hole with insulation.

5. Attach the CHV-TSTATEX-FCU back plate to the electrical box using the two included #06-32 x 1" pan head screws.
6. Attach the face plate.
7. Insert batteries and attach the battery compartment cover.
8. Turn HVAC system power **ON**.

CAUTION: Replace all batteries in the device at the same time. Mixing old and new batteries in the device may result in battery leakage and equipment damage.

NOTE: Crestron has provided small slots on either side of the battery cover, designed to allow a flathead screwdriver to be inserted to assist in removal.

Installation into Electrical Box

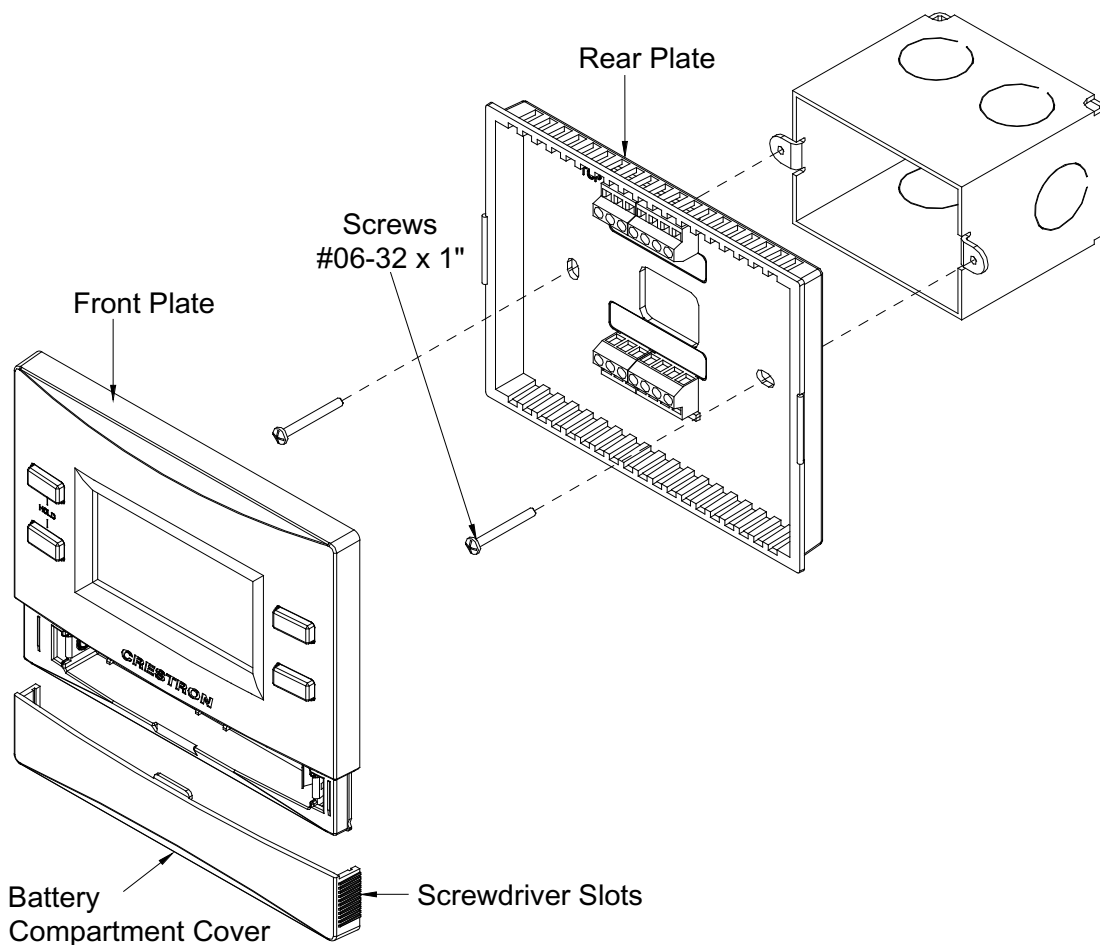

DIP Switch Setup

The following describes the CHV-TSTATEX-FCU DIP switch settings.

1. Install two AA batteries (included) in the battery compartment.
2. Locate the DIP switches inside the unit and configure the parameters per the tables below.

DIP Switch Settings

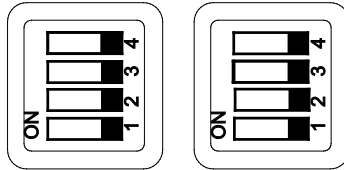

Left Switch

#	DESCRIPTION	ON	OFF
4	Lockout setup mode	Unlocked	Locked
3	HOLD button behavior	Toggles between F/C	Toggles <i>Hold</i> mode
2	Medium fan speed	Enabled	Disabled
1	Low fan speed	Enabled	Disabled

Right Switch

#	DESCRIPTION	ON	OFF
4	<i>Heat</i> mode	Enabled	Disabled
3	<i>Cool</i> mode	Enabled	Disabled
2	<i>Auto</i> mode	Enabled	Disabled
1	<i>Auto</i> mode behavior	Single setpoint	Dual setpoint

By default, the CHV-TSTATEX-FCU is configured to be powered by two AA alkaline batteries. To extend battery life, the device also receives power from the HVAC system by drawing a small amount of current through the heat or cool terminals. This is known as *Steal Power* mode.

To enable this feature, locate the **POWER** slide switch inside the unit and slide it to **STEAL** (This is the default factory setting on the CHV-TSTATEX-FCU).

POWER Slide Switch

STEAL 24VAC

NOTE: *Steal Power* mode will not draw enough current to cause the external heat or cool relays to close. More specifically, when the unit is not making a call for heat, it will draw power through the R and W terminals. When the unit is making a call for heat, it will draw power through the R and Y terminals. (This will not work if the thermostat has been wired for a cool only application.). The CHV-TSTATEX-FCU must be wired for heat control in order to take advantage of *Steal Power* mode.

NOTE: In *Steal Power* mode, even when an auxiliary power source is available, the unit will continue to enter a communications sleep state, waking every 30 seconds or one minute (based on the infiNET EX Sleep Time setting) to exchange data with the control system. Refer to “Remote Operation” which starts on page 25 for details.

NOTE: *Steal Power* mode may cause problems with some types of HVAC systems, such as indicating a false heat or cool call. If this occurs, do not use *Steal Power* mode.

If the thermostat will be wired so that 24 Volts AC will always be present on the **24C** terminal, slide the **POWER** switch to **24VAC**. No batteries will be required in this mode.

NOTE: When the unit detects 24 VAC is present, it will no longer “sleep”, meaning it will offer real-time communication with the control system.

NOTE: When the unit is powered from a constant 24 VAC supply, there may be a slight discrepancy between the ambient temperature displayed on the thermostat and the actual room temperature. This discrepancy will also be seen when switching from **STEAL** to **24VAC**. This is normal and the discrepancy will disappear within approximately 10 minutes.

Wiring the CHV-TSTATEX-FCU to the HVAC System

Make the necessary connections as called out in the illustrations that follow. A flat head screwdriver (not supplied) is required to attach the control wires from the HVAC system. Apply power after all connections have been made.

The illustrations on the following pages show examples for connection to various types of HVAC systems. If your system does not match any of the systems described below, contact Crestron Technical Support for assistance.

Connections for the CHV-TSTATEX-FCU

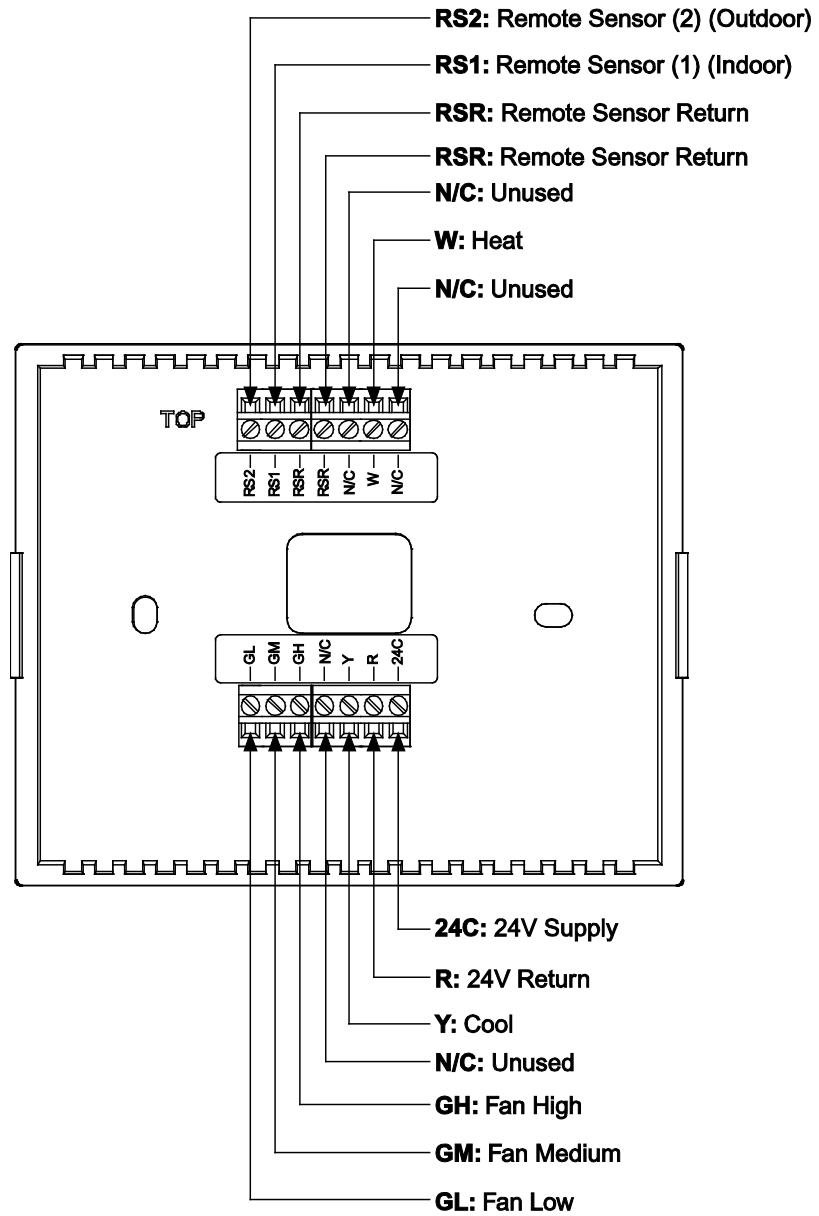

NOTE: 24 Volt power is returned through the **R** connector. Refer to wiring diagrams on the following pages.

NOTE: Refer to “DIP Switch Setup” which starts on page 11 for DIP switch settings.

CHV-TSTATEX-FCU Wiring Diagram

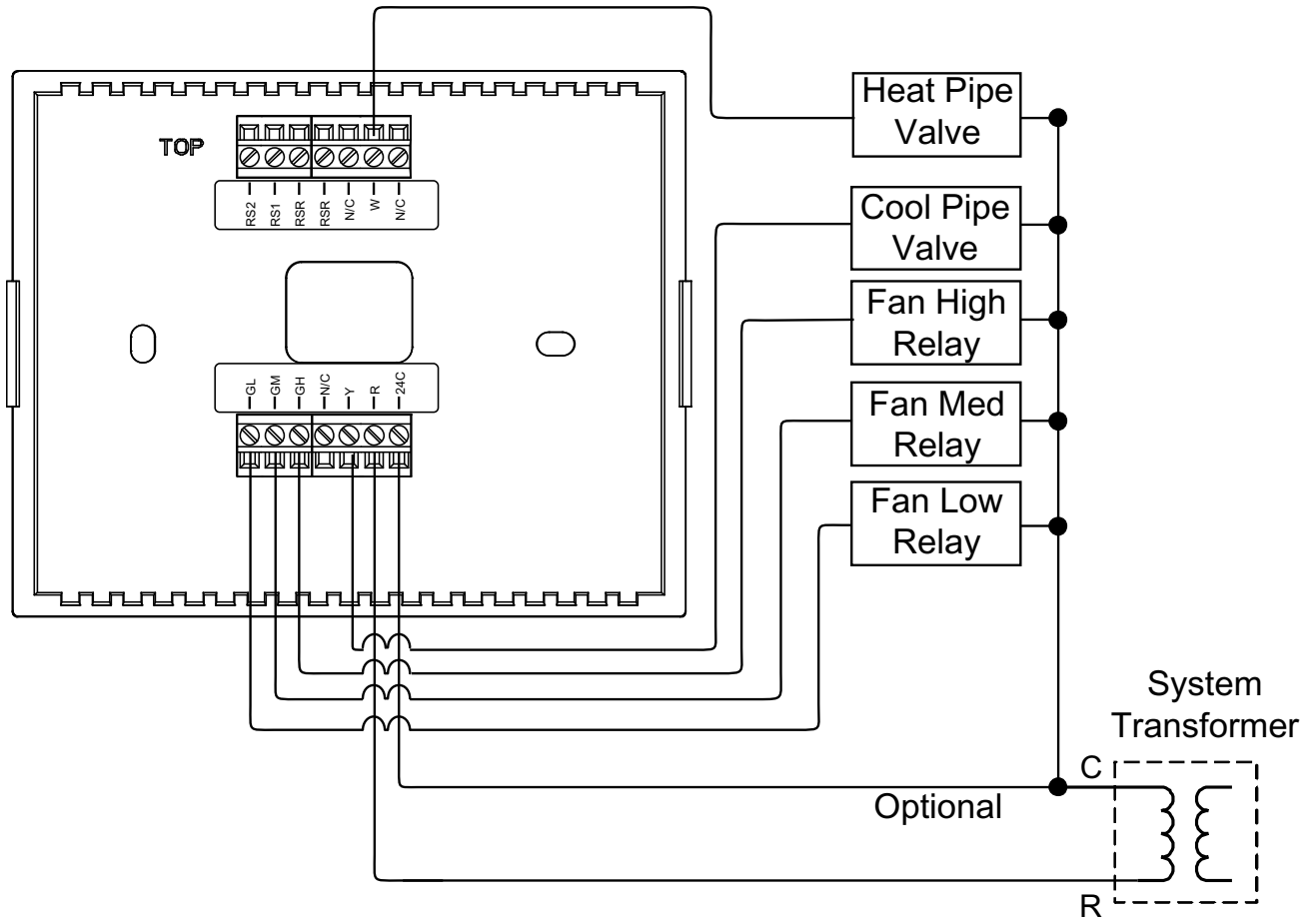

CHV-TSTATEX-FCU Sensor Wiring

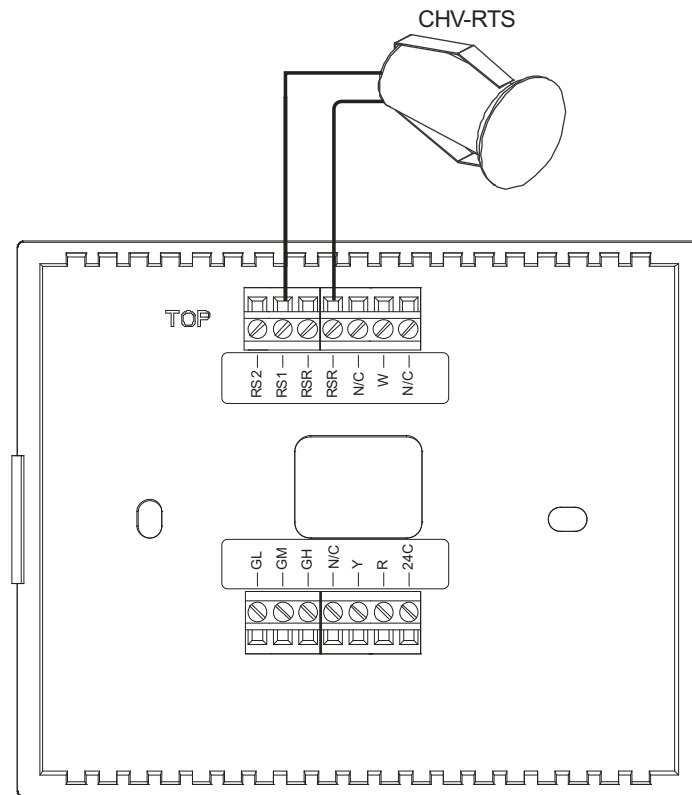

Basic Setup

Basic Thermostat Setup

The following describes the most common setup requirements. For full details on all setup options, refer to “Advanced Setup” which starts on page 18.

Place the CHV-TSTATEX-FCU in the *Setup* mode by doing the following:

1. Press and hold the **FAN** button.
2. While the **FAN** button is being held, press and hold the ▲ and ▼ buttons simultaneously.
3. Hold all three buttons for five seconds, after which the unit will enter *Setup* mode. The display shows the Temperature Scale function (FC).



Use ▲ or ▼ to choose the temperature units: F (setpoint in whole degrees Fahrenheit), C1 (setpoint in whole degrees Celsius) or C2 (setpoint in half degrees Celsius).

When setting parameters (such as when choosing between Fahrenheit or Celsius display), pressing the ▲ or ▼ button will increment or decrement the value. Value change occurs when button is released.

Joining an infiNET EX Network

Before a CHV-TSTATEX-FCU can be used on an infiNET EX network, it must first join an infiNET EX network by being acquired by an infiNET EX gateway (e.g., CEN-RFGW-EX).

NOTE: A CHV-TSTATEX-FCU can be acquired by only one gateway.

To acquire a CHV-TSTATEX-FCU, perform the following:

1. Put the CEN-RFGW-EX into *Acquire* mode, from the unit itself or from Crestron Toolbox, as described in the latest revision of the CEN-RFGW-EX Operations & Installation Guide (Doc. 6706), which is available from the Crestron Web site (www.crestron.com/manuals).

NOTE: In an environment where multiple gateways are installed, only one gateway at a time should be in *Acquire* mode.

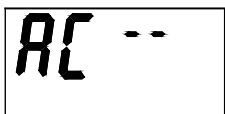
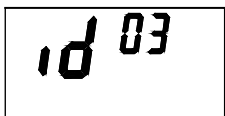

2. Ensure the unit is in *Setup* mode (refer to “Basic Thermostat Setup” above or “Setup Mode” which starts on page 18) and that *Acquire* mode (AC) is selected.
3. Press **MODE** until the “infiNET EX ID” function is displayed (id). Use ▲ and ▼ to choose the infiNET EX ID.
4. Press **MODE** until the “Start infiNET EX Acquire” function is displayed (AC).
5. Press ▲ or ▼ on the CHV-TSTATEX-FCU to start the acquire process: The display shows flashing “—” (in progress). When finished, the display shows “00” (finished, found gateway) or “E#” (finished, could not find gateway), where # represents an error code.
6. Once all devices have been acquired, take the CEN-RFGW-EX out of *Acquire* mode by pressing its **ACQUIRE** button. Press **FAN** on the thermostat to exit *Setup* mode.

NOTE: The acquire process can take up to 15 seconds. The acquire process cannot be aborted.

NOTE: “E1” indicates that search time has expired and no gateway was found. To enable the channel, refer to “Start infiNET EX Acquire” in “Setup Mode Parameters/Functions” which starts on page 19.

Leaving an infiNET EX Network

To leave a network, press and hold the **FAN**, **▲** and **▼** buttons simultaneously for five seconds. Press **MODE** until the unacquire function is displayed (UA). Press **▲** or **▼** on the CHV-TSTATEX-FCU to start the unacquire process. Refer to “Verifying Communication Status” on page 21 for a list of codes displayed once the process is completed. Press **FAN** on the thermostat to exit *Setup* mode.

Advanced Setup

Setup Mode

After the CHV-TSTATEX-FCU is installed, it is necessary to set it up for a particular heating/cooling system. Please note that some of the setup parameters listed below will not always be shown since they are dependent upon other thermostat settings. Refer to “Setup Mode Parameters/Functions”, which starts on page 19 for details.

Place the CHV-TSTATEX-FCU in the *Setup* mode by doing the following:

1. Press and hold the **FAN** button.
2. While the **FAN** button is being held, press and hold the **▲** and **▼** buttons simultaneously.
3. Hold all three buttons for five seconds, after which the unit will enter *Setup* mode.

Once in *Setup* mode, the display will indicate the currently selected setup parameter/function. Press and release the **MODE** button quickly (must be released within one second) to change to the next parameter/function in the list.

NOTE: Holding the **MODE** button for more than one second will reset the currently selected parameter/function to its default value.

When setting parameters (such as when choosing between Fahrenheit or Celsius display), pressing the **▲** or **▼** button will increment or decrement the value. Value change occurs when button is released.

When a function is selected (such as when starting an infiNET EX acquire), pressing either **▲** or **▼** will execute the function.

To exit from *Setup* mode, press the **FAN** button on the CHV-TSTATEX-FCU.

CHV-TSTATEX-FCU LCD Display (Setup Mode)

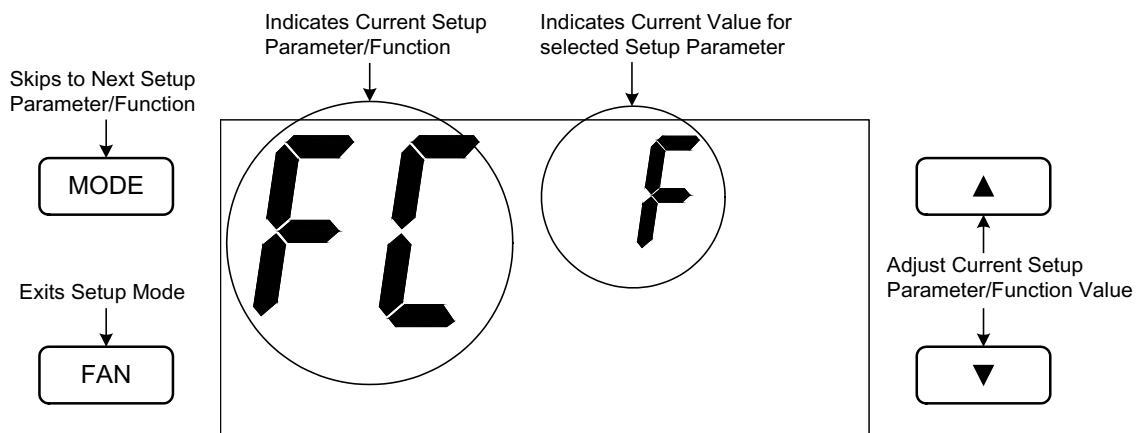

NOTE: When the CHV-TSTATEX-FCU is in *Setup* mode the large seven-segment displays will show the current setup parameter/function. The small seven-segment displays will show the current value for the selected setup parameter, if applicable, or it will display “—” when a function is selected. All other display elements will be hidden (refer to “LCD Display” which starts on page 26).

NOTE: While in *Setup* mode, a period of one minute with no button activity will cause the CHV-TSTATEX-FCU to revert to standard operation, unless a function (such as an infiNET EX acquire) is executing.

Setup Mode Parameters/Functions

The following table shows the available setup parameters/functions.

Setup Mode Parameters/Functions

PARAMETER/ FUNCTION	CODE	VALID VALUES	DEFAULT VALUE	NOTES
Temperature Scale	FC	F, C	F	Sets units to use for temperature display (Fahrenheit or Celsius)
Backlight Timeout	bL	1 – 4 seconds or disabled (--)	4 seconds	Sets the number of seconds the backlight will remain lit after a button press
Auto Dead Band	db	2 – 6 (for Fahrenheit) or 1 – 3 (for Celsius)	2	Used to set minimum separation between heat and cool setpoints (with dual setpoints) or maximum drift before system latches alternate mode (with single setpoint)
Heat Setpoint Limit	HL	50-90	80	Sets the highest heat setpoint that is allowed
Cool Setpoint Limit	CL	50-90	60	Sets the lowest cool setpoint that is allowed
Temperature Offset	to	-9 to +9 (for Fahrenheit) or -5 to +5 (for Celsius)	0	Permits recalibration of room temperature sensor; This is the number of degrees added to or subtracted from the actual temperature; This adjustment changes the actual regulation temperature, not just the display
Heat Anticipator	HA	1 – 6	3	Lower setting results in more frequent cycles and faster response (tighter regulation); Higher setting results in less frequent cycles and slower response (looser regulation); The default value should suffice in nearly all installations
Cool Anticipator	CA	1 – 6	3	Lower setting results in more frequent cycles and faster response (tighter regulation); Higher setting results in less frequent cycles and slower response (looser regulation); The default value should suffice in nearly all installations

(Continued on following page)

Setup Mode Parameters/Functions (Continued)

PARAMETER/ FUNCTION	CODE	VALID VALUES	DEFAULT VALUE	NOTES
Remote sensors	Sn	i, r, ir	i	i – internal sensor only (When no remote sensor is detected, only this option is available); r – remote sensor only (Only available when a remote sensor has been detected) ir – average internal and remote sensors
Check Firmware Version	rE	Firmware version is displayed in xx.yy.zz format. “—” can also be displayed.	--	When firmware version is not yet shown, display will be “—”; Each press of the ▲ or ▼ button will cycle to the next portion of the version number
infiNET EX ID (RF ID)	id	01 and 03 – FE	01	Sets the infiNET EX ID. SIMPL Windows restricts infiNET EX devices to an ID range of 03 – 20
infiNET EX Sleep Time	SL	Short (S) or Long (L)	L	Indicates thermostat update rate; Setting for fewer updates (“L”) will conserve battery power.
Start infiNET EX Acquire	AC	Not started (--) In progress (flashing --) Finished, found GW (00) Finished, could not find GW (E#, where # represents an error code)	N/A	Refer to “Verifying Communication Status” which starts on page 21 for details
Unacquire Gateway	UA	Not started (--) In progress (flashing --) Finished, success (00) Finished, failed (E#, where # represents an error code)	N/A	Refer to “Verifying Communication Status” which starts on page 21 for details
Communication s check	CC	Error (E# - where # is a number from 0 to 7) No problems (00)	N/A	Refer to “Verifying Communication Status” which starts on page 21 for details
Check Battery Life	bA	Not started (--) Estimated remaining battery life (0 – 99)	N/A	Gives estimated remaining battery life in percent
Restore Factory Defaults	Fd	Not started (--) In progress (blank or flashing --) Finished (00) Button not held long enough (Er)	N/A	Restores all setup parameters to their default settings; To prevent accidentally performing this action, you must press and hold either the ▲ or ▼ button for three seconds for this function to execute

(Continued on following page)

Setup Mode Parameters/Functions (Continued)

PARAMETER/ FUNCTION	CODE	VALID VALUES	DEFAULT VALUE	NOTES
Perform Heat Call Test (Toggle)	H	Not started/Heat call off (--) Heat call on (on) (also, "H" icon will turn on)	N/A	Will test the heat call output; Bypasses short-cycle timers; Useful for technician system testing; Note that calling the heat may activate other relays in the thermostat as required, such as the fan output for heat pump or dual-fuel types
Perform Cool Call Test (Toggle)	C	Not started/Cool call off (--) Cool call on (on) (also, "C" icon will turn on)	N/A	Will test the cool call output. Bypasses short-cycle timers; Useful for technician system testing; Note that calling the cooling may activate other relays in the thermostat as required, such as the fan output
Perform Fan Call Test (Toggle)	F	Not started/Fan call off (--) Fan call on (on) (also, "F" icon will turn on)	N/A	Same as above, for fan; Note that only the fan relay can be activated for a fan call test
Perform Self Test	St	Not started (--) In progress (flashing --) Finished, self test ok (00) Finished, self test failed (E#, where # represents an error code)	N/A	Refer to "Self-Test Results" which starts on page 22 for details

Verifying Communication Status

To verify communication status, enter *Setup* mode as described in "Basic Setup" which starts on page 16. Press **MODE** until the "AC", "UA" or "CC" function is displayed. Press ▲ or ▼ on the CHV-TSTATEX-FCU to verify the communication status.

Communication Error Codes

Status/ Error Code	MEANING FOR ACQUIRE "AC"	MEANING FOR UNACQUIRE "UA"	MEANING FOR COMMUNICATION CHECK "CC"
00	Success	Success	No problems found
E1	No gateway found	Failed or no previous gateway information was present	No gateway information present
E2	GW found but rejected device	N/A	N/A
E3	Radio operation not available	Radio operation not available	Radio operation not available
E4	N/A	N/A	N/A
E5	N/A	N/A	N/A
E6	N/A	N/A	Network communication not possible
E7	N/A	N/A	Device not joined to a gateway

Self-Test Results

These error/status codes are returned when performing a self-test operation, enter *Setup* mode as described in “Basic Setup” which starts on page 16. Press **MODE** until the “AC”, “UA” or “CC” function is displayed. Press ▲ or ▼ on the CHV-TSTATEX-FCU to verify the communication status.

Self-Test Error Codes

ERROR CODE	SUMMARY	CORRECTIVE ACTION	REMARKS
00	Success	None	No detectable problems found.
E0	Low battery warning	Check and/or replace batteries	Error is only returned when current power configuration requires batteries
E1	24VAC usage warning	Check power configuration	Error is set when 24 VAC appears to be available but is not configured properly (slide switch position)
E2	Display operation	Return unit	Device display may not be operating properly
E3	NV memory usage	Replace unit if feasible	Retention of non-volatile setup and operation parameters may be compromised
E4	Poor link quality	Perform general network debugging	Poor communication link to gateway may be consuming extra power and lowering battery life
E5	Gateway acquire information	Acquire device or check network	Device cannot communicate with a gateway. Normal result for unacquired device
E6	Network communication error	Additional network communication issues detected	Normal result for unacquired device
E7	Poor network communication	Additional indicator of poor communications link	Often associated with excessive network hops; Consider moving device closer to gateway or splitting network with additional gateways for better coverage

Operation

System Mode

The **MODE** button on the CHV-TSTATEX-FCU will cycle the unit through all available system modes in the following order: *Off*, *Heat*, *Emergency Heat* (for heat pump and dual-fuel systems), *Cool* and *Auto* (if enabled in Setup).

The system mode will change upon release of the **MODE** button and the selected mode will become operational five seconds after the mode has been entered.

Off Mode

In *Off* mode, all HVAC systems are disabled.

Heat Mode

In *Heat* mode, the thermostat uses the heating system to maintain the setpoint temperature.

Cool Mode





In *Cool* mode, the thermostat uses the cooling system to maintain the setpoint temperature.

Auto Mode

In *Auto* mode, the thermostat allows the system to switch between *Heat* and *Cool* automatically as needed to maintain the setpoint temperature. By default, the CHV-TSTATEX-FCU has been configured with *Auto* mode disabled, meaning it is not available from the thermostat itself or via another interface such as a touch screen.

In order to enable *Auto* mode, you must enter *Setup* mode and change the “AU” setting from “--” to either “d” (dual setpoint) or “S” (single setpoint). Refer to “Setup Mode” which starts on page 18 for details.

Once *Auto* mode has been enabled, you can access it from the CHV-TSTATEX-FCU controls as follows:

1. Press the **MODE** button until both the flame  and snowflake  icons appear in the display. This indicates *Auto* mode is now active.
2. Use the ▲ and ▼ buttons to adjust the setpoint. Actual operation will depend on whether you are using single or dual setpoints.
 - a. In dual setpoint *Auto* mode, the first press of the ▲ or ▼ buttons (or second press if the first press simply turned on the backlight) will cause either the flame  or snowflake  icon to flash rapidly. This indicates which setpoint will be adjusted by subsequent presses of the ▲ or ▼ buttons. To adjust or view the alternate setpoint, press the **MODE** button while the icon is flashing. This will cause the alternate icon to flash and now the ▲ and ▼ buttons will adjust that setpoint. The flashing icon will time out after five seconds of no button activity.
 - b. In single setpoint *Auto* mode, use the buttons to adjust the setpoint as usual.

Dual Setpoint Auto Mode (“AU” = “d” in Setup Mode)

In dual setpoint *Auto* mode, separate heat and cool setpoints are used. When the ambient temperature drops below the heat setpoint, the unit will call for heat to maintain the heat setpoint. When the ambient temperature rises above the heat setpoint, the unit will not call for cooling until the temperature exceeds the cool setpoint. When the ambient temperature drops below the cool setpoint, the unit will not call for heating until the temperature is below the heat setpoint.

When dual setpoint *Auto* mode has been enabled, the Auto Dead Band is used to maintain a minimum separation between the heat and cool setpoints. If this separation is violated by a setpoint adjustment, the other setpoint will be automatically adjusted.

For example, if the heat setpoint is at 68 degrees, the cool setpoint is at 72 degrees and the Auto Dead Band is set to 4 degrees, if you lower the cool setpoint to 71 degrees, the heat setpoint will automatically be adjusted to 67 degrees to maintain the 4 degree Auto Dead Band separation.

In dual setpoint *Auto* mode, the CHV-TSTATEX-FCU display will indicate whichever setpoint is closer to the ambient temperature. Both the heat and cool setpoints can be viewed simultaneously using a touch screen.

NOTE: When using a Dual setpoint, the CHV-TSTATEX-FCU has a 20 minute change limiter to prevent system toggling.

Single Setpoint Auto Mode (“AU” = “S” in Setup Mode)

In single setpoint *Auto* mode, a single setpoint is used for regulation at all times, regardless of whether the system is heating or cooling. The Auto Dead Band (“db”) setup parameter is used to determine when to switch between heating and cooling.

For example, if the setpoint is at 70 degrees and the Auto Dead Band is set to 2 degrees, if the system is cooling, it will not start heating until the ambient temperature drops below 68 degrees (setpoint – Auto Dead Band). Once the unit has switched to heating, it will not resume cooling until the ambient temperature rises above 72 degrees (setpoint + Auto Dead Band).

A larger value for the Auto Dead Band setting will result in less cycling between heating and cooling but can result in large temperature swings during the course of the day. Smaller values for the Auto Dead Band setting will result in tighter temperature regulation but more frequent cycling between heating and cooling.

NOTE: When using a single setpoint, the CHV-TSTATEX-FCU has a 20 minute change limiter to prevent system toggling.

Fan

The **FAN** button toggles the fan setting between fan AUTO, Fan High (F3), Fan Medium (F2) and Fan Low (F1). When set to AUTO, a fan call will be made whenever the system makes a cool call or when the system makes a heat call (if the DIP switch is set to “Enabled”). When set to F3, F2 or F1 the fan will always run.

Setpoints

The setpoint is the user selectable temperature you want the system to maintain.

The ▲ and ▼ buttons will change the current setpoint by one degree F or C.

If the ▲ or ▼ button is held down for two seconds, the unit will enter an auto-repeat state and the setpoint will adjust rapidly until the button is released or until the upper (or lower) limit is reached.

Some users will want to have setpoints change automatically based on the day of the week and the time of day. For example, in the winter they may want to lower the heat setpoint while they sleep to lower heating costs. To accommodate this, the CHV-TSTATEX-FCU provides a “Scheduled Heat Setpoint” and a “Scheduled Cool Setpoint” which can be specified by the control system program. This is handled automatically by the “Crestron CHV-TSTATEX-FCU w/5-2 Scheduler” module provided with the Crestron Database. Refer to the SIMPL Windows help file for details.

For dual setpoint operation, refer to “Auto Mode” which starts on page 23.

Hold

Hold allows the user to adjust the setpoint and will maintain that setpoint until the unit is taken out of *Hold*. This means that any change to the scheduled heat or cool setpoint that occurs while in *Hold* will be ignored until the unit is taken out of *Hold*.

Pressing the **MODE** and **FAN** buttons simultaneously will cause the unit to enter *Hold* if *Hold* is not yet active and the system mode is *Heat*, *Emergency Heat* or *Cool*.

Pressing the **MODE** and **FAN** buttons simultaneously when *Hold* is active will cause the unit to exit from *Hold* and recall either the scheduled heat setpoint or scheduled cool setpoint as appropriate to the system mode.

If the system is in single setpoint *Auto* mode, exiting from *Hold* will recall the scheduled auto setpoint. If the system is in dual setpoint *Auto* mode, upon exiting from *Hold*, the auto cool setpoint becomes the scheduled cool setpoint and the auto heat setpoint becomes the scheduled heat setpoint.

Pressing the **MODE** and **FAN** buttons simultaneously when the system mode is *Off* will have no effect.

When *Hold* is active, the unit will continue to adjust the current setpoint when the ▲ or ▼ buttons are pressed. The unit will also continue to adjust the current setpoint when the setpoint signal from the control system changes.

When the system mode changes to *Heat* or *Emergency Heat*, the current setpoint will be set to the scheduled heat setpoint.

When the system mode changes to *Cool*, the current setpoint will be set to the scheduled cool setpoint.

Remote Operation

As an infiNET EX device, the CHV-TSTATEX-FCU can be controlled remotely via a Crestron control system. Most often, control of the thermostat will be achieved via a touch screen or Web-based graphical interface. In order to extend battery life, the thermostat will only communicate with the control system once every 30 seconds or one minute, based on the infiNET EX Sleep Time setting. Because of this, there will be a noticeable delay between the time a button is pressed on a touch screen and when the thermostat reacts to the command. To account for this, the CHV-TSTATEX-FCU modules written by Crestron and provided in the Crestron Database will mimic the feedback from the thermostat so that the user will see an immediate response on the touch screen.

Likewise, pressing a local button on the thermostat (for example, setpoint raise or lower) will not cause an immediate change to the corresponding display on a touch

screen. Instead, the thermostat will wake up shortly after the last button press to send its updated status to the control system.

If the thermostat is wired to have the optional 24 VAC at the **24C** terminal and the power switch is set for 24V, there will not be a delay in feedback.

LCD Display

CHV-TSTATEX-FCU LCD Display

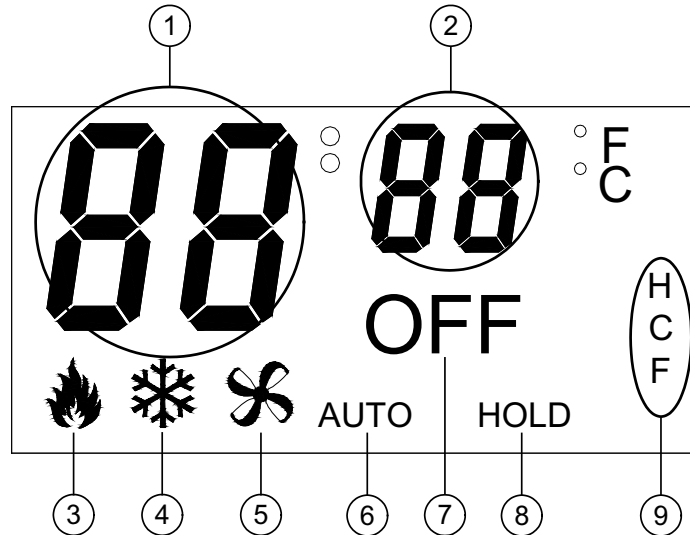

LCD Display Elements

#	LCD DISPLAY ELEMENT	DESCRIPTION
1	Large 7-segment digits	Indicates current ambient temperature*. In <i>Setup</i> mode, indicates current setup parameter/function; Display range is limited to -9° to 99°F (-9° to 43°C); If the ambient temperature is above 99°, the display will indicate 99°; If the ambient temperature is below -9°, the display will indicate -9°
2	Small 7-segment digits	Indicates current setpoint (in F or C) in whole degrees; In <i>Setup</i> mode, indicates current value for selected setup parameter
3	Flame icon	Displayed when the system mode is <i>Heat</i> ; Displayed with snowflake icon when system is in <i>Auto</i> mode
4	Snowflake icon	Displayed when the system mode is <i>Cool</i> ; Displayed with flame icon when system is in <i>Auto</i> mode
5	Fan icon	Displayed at all times
6	AUTO indicator	Displayed when FAN setting is AUTO If this is not displayed, FAN is always ON
7	OFF indicator	Displayed when the system mode is <i>Off</i>
8	HOLD indicator	Displayed when the HOLD setting is active
9	H, C & F indicators	H – Displayed whenever a Heat Call is being made; C – Displayed whenever a Cool Call is being made; F – Displayed whenever a Fan Call is being made

* When the CHV-TSTATEX-FCU detects a low battery condition (approximately one month of battery life remaining), the display will alternate “Lo” in place of the ambient temperature once per second.

Programming Software

Have a question or comment about Crestron software?

Answers to frequently asked questions (FAQs) can be viewed in the Online Help section of the Crestron Web site. To post a question or view questions you have submitted to Crestron's True Blue Support, log in at www.crestron.com/support. First-time users will need to establish a user account.

Earliest Version Software Requirements for the PC

NOTE: Crestron recommends that you use the latest software to take advantage of the most recently released features. The latest software is available from the Crestron Web site (www.crestron.com/software).

Crestron provides an assortment of Microsoft Windows[®] based software tools to develop a customized system. Use SystemBuilder, D3 Pro or SIMPL Windows to create a program to control the CHV-TSTATEX-FCU. Customers whose focus is on lighting systems may prefer to use the D3 Pro software since it is designed especially for creating lighting and environmental system control applications. Customers already familiar with SIMPL Windows who are including a lighting system as part of an overall control system project may prefer to continue using SIMPL Windows.

Programming with Crestron SystemBuilder

SystemBuilder is a comprehensive programming environment. Appropriate for most systems, it can quickly and easily generate a complete working program including both control processor logic and touch screen graphics.

Programming with D3 Pro

Crestron's D3 Pro lighting software provides all the tools necessary to create a complete Crestron lighting system for residential applications. The lighting system includes the control system logic program, touch screen projects and keypad programming, Documentation and real-time lighting adjustment capabilities.

As with all Crestron software, D3 Pro provides extensive right-click and drag-and-drop functionality in addition to convenient keyboard shortcuts for frequently used functions and commands.

Programming is organized into six system **Views** of the lighting system, each providing a moveable toolbox of devices such as interfaces, fixtures and control modules. You can add a device to your system simply by selecting it from one of the toolboxes and dragging it to a room. The available toolboxes differ depending on the View but all Views include a "General" toolbox that allows you to add areas and rooms at any time.

Programming with SIMPL Windows

NOTE: While SIMPL Windows can be used to program the CHV-TSTATEX-FCU, it is recommended to use SystemBuilder for configuring a system.

SIMPL Windows is Crestron’s premier software for programming Crestron control systems. It is organized into two separate but equally important “Managers”: Configuration and Program.

Configuration Manager

Configuration Manager is the view where programmers “build” a Crestron control system by selecting hardware from the *Device Library*.

1. To incorporate the CHV-TSTATEX-FCU into the system:

NOTE: If connecting to the MC3, drag the CHV-TSTATEX-FCU directly to the MC3 and proceed to step 2.

- a. Drag the CEN-RFGW-EX (gateway) from the Wireless Receivers | Wireless Receivers (RF) folder of the *Device Library* and drop it in the *System Views*.

Locating the CEN-RFGW-EX in the Device Library

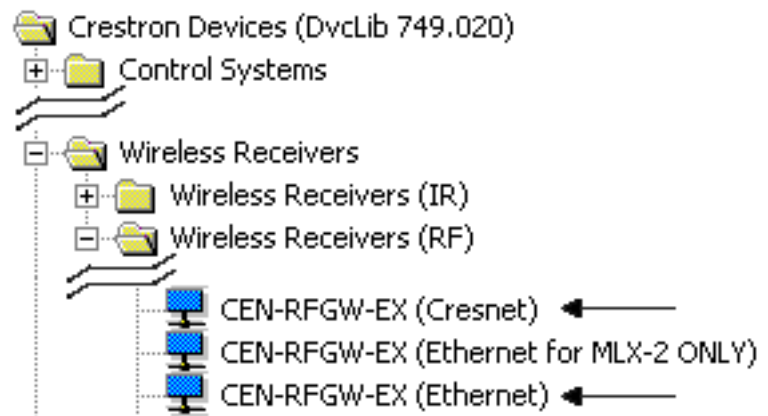

- b. Drag the CHV-TSTATEX-FCU from the Wireless Remotes | Wireless Remotes (RF) folder of the *Device Library* and drop it on the CEN-RFGW-EX.

Locating the CHV-TSTATEX-FCU in the Device Library

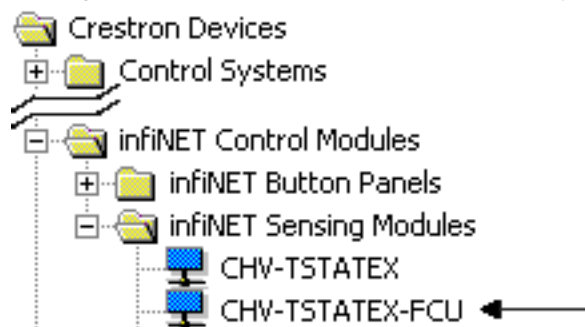

The system tree of the control system displays the CHV-TSTATEX-FCU in the appropriate slot(s) with a default RF ID as shown in the following illustration.

C2Net Device, Slot 8

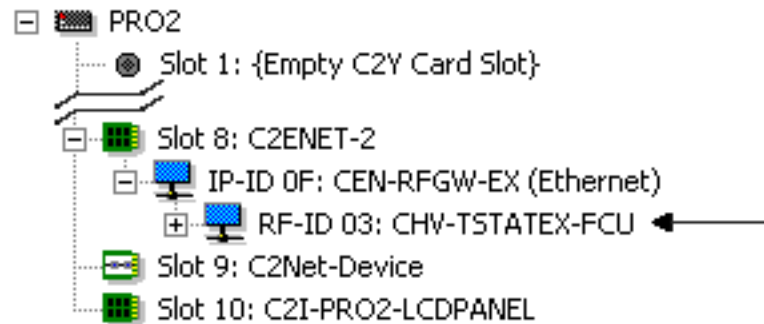

2. If additional CHV-TSTATEX-FCU devices are to be added, repeat step 1b for each device. Each CHV-TSTATEX-FCU is assigned a different RF ID number as it is added.

NOTE: If using an MC3, drag any additional CHV-TSTATEX-FCU devices directly to the MC3.

3. If necessary, double click a device to open the “Device Settings” window and change the RF ID, as shown in the following illustration.

“Device Settings: Crestron CHV-TSTATEX-FCU” Window

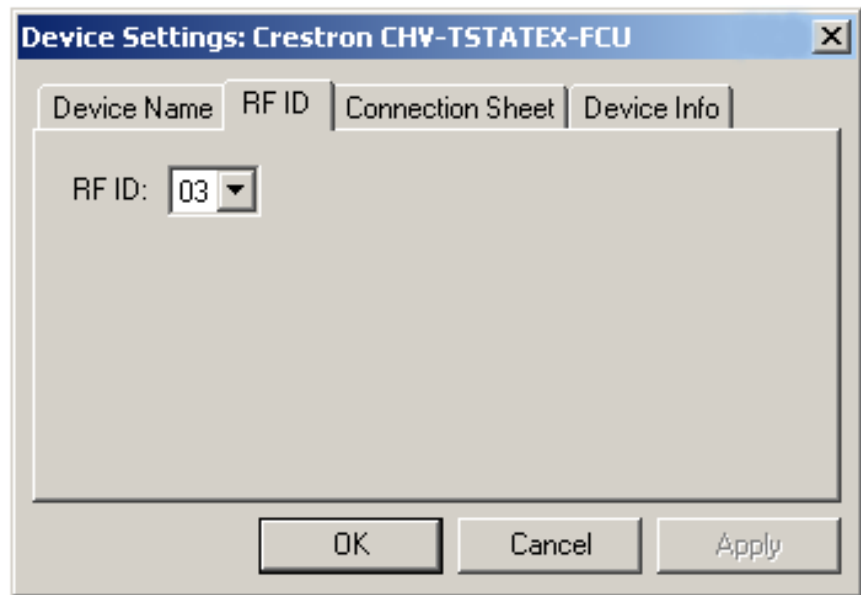

NOTE: The ID code specified in the SIMPL Windows program must match the RF ID of each unit. Refer to “Identity Code” on page 9.

Program Manager

Program Manager is the view where programmers “program” a Crestron control system by assigning signals to symbols.

The symbol can be viewed by double clicking on the icon or dragging it into *Detail View*. Each signal in the symbol is described in the SIMPL Windows help file (F1).

Uploading and Upgrading

Crestron recommends using the latest programming software and that each device contains the latest firmware to take advantage of the most recently released features. However, before attempting to upload or upgrade it is necessary to establish communication. Once communication has been established, files (for example, programs or firmware) can be transferred to the control system (and/or device). Finally, program checks can be performed (such as changing the device ID or creating an IP table) to ensure proper functioning.

Establishing Communication

Use Crestron Toolbox for communicating with the CHV-TSTATEX-FCU; refer to the Crestron Toolbox help file for details. There is a single method of communication: indirect communication.

Indirect Communication

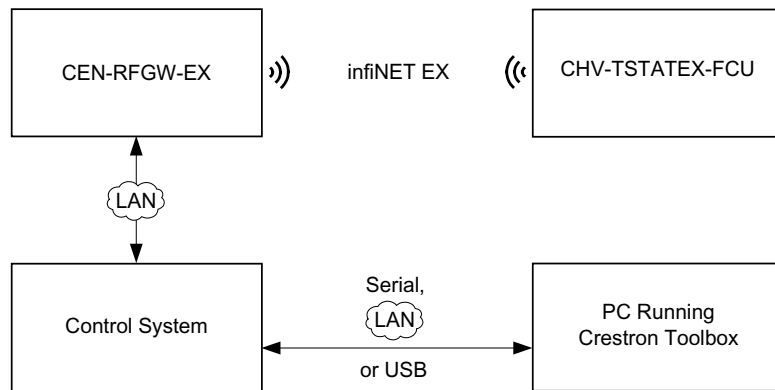

Indirect Communication with MC3

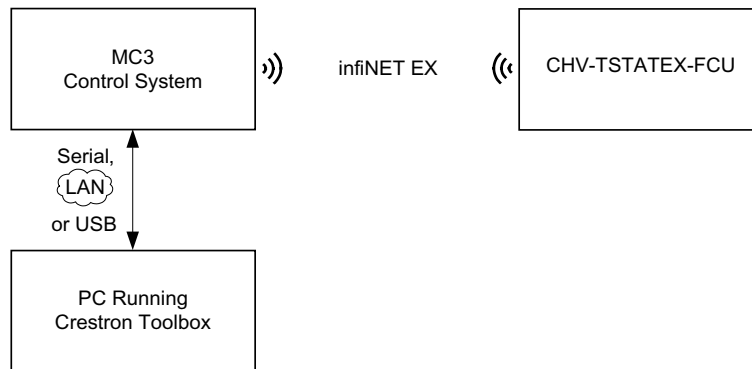

The CHV-TSTATEX-FCU connects to the CEN-RFGW-EX (gateway), which connects to control system via Ethernet, or, the CHV-TSTATEX-FCU connects directly to an MC3 Control System.

Establish communications between the PC and the control system as described in the latest version of the 2-Series Control Systems Reference Guide (Doc. 6256). If connecting to the MC3, refer to the latest version of the MC3 3-Series Control System Operations Guide (Doc. 7095).

Programs and Firmware

Program or firmware files may be distributed from programmers to installers or from Crestron to dealers. Firmware upgrades are available from the Crestron Web site as new features are developed after product releases. One has the option to upload programs via the programming software or to upload and upgrade via the Crestron Toolbox. For details on uploading and upgrading, refer to the SIMPL Windows help file, or the Crestron Toolbox help file.

SIMPL Windows

If a SIMPL Windows program is provided, it can be uploaded to the control system using SIMPL Windows or Crestron Toolbox.

Firmware

Check the Crestron Web site to find the latest firmware. (New users may be required to register to obtain access to certain areas of the site, including the FTP site.)

Upgrade CHV-TSTATEX-FCU firmware via Crestron Toolbox.

1. Establish communications with the CHV-TSTATEX-FCU and display the “System Info” window.
2. Select **Functions | Firmware...** to upgrade the CHV-TSTATEX-FCU firmware.

NOTE: Since the CHV-TSTATEX-FCU might be “asleep”, there may be a delay of one minute or less before the update starts.

Program Checks

Using Crestron Toolbox, display the network device tree (**Tools | Network Device Tree View**) to show all network devices connected to the control system and all infiNET devices that have been acquired by the CHV-TSTATEX-FCU (CEN-RFGW-EX). Right-click on the CHV-TSTATEX-FCU (CEN-RFGW-EX) to display actions that can be performed on the CHV-TSTATEX-FCU (CEN-RFGW-EX).

Problem Solving

Troubleshooting

The following table provides corrective action for possible trouble situations. If further assistance is required, please contact a Crestron customer service representative.

CHV-TSTATEX-FCU Troubleshooting

TROUBLE	POSSIBLE CAUSE(S)	CORRECTIVE ACTION
No display.	No power from system.	Check for 24V AC on 24C connector. Check circuit breaker powering furnace or boiler. Check thermostat wiring. Check batteries (if running on battery power).
	Incorrect mounting to back plate.	Check thermostat mounting.
Device does not follow control system commands.	Device is not communicating with the CEN-RFGW-EX.	Open Crestron Toolbox and select the Network Device Tree View. Expand the tree until the gateway to be managed is selected. Right-click the NET ID of the selected gateway to open the sub-menu and select Functions infiNET EX Gateway... If device is not listed, acquire the device to the infiNET EX network (refer to "Joining an infiNET EX Network" which starts on page 16).
	RF ID of device (or the gateway ID) is not set to match the RF ID of the SIMPL Windows program.	Use the Network Device Tree infiNET EX network in Crestron Toolbox to poll the infiNET EX network. Verify that the RF ID for the infiNET EX device is set to match the RF ID specified in the SIMPL Windows program.
Heating/Cooling system is not operating.	No power to thermostat.	Check circuit breaker. Check for 24V AC on 24C connector. Check circuit breaker powering furnace or boiler. Recheck wiring connections. Check batteries, replace if necessary.
Cannot change setpoint setting.	The upper or lower temperature limits were reached.	Heat setpoint lower limit is 38° (3°). Cool setpoint high limit is 59° (37°C). Heat setpoint high limit and cool setpoint low limit is user defined is defined during setup in the "HL" and "CL" screens. Refer to "Setup Mode Parameters/Functions" which starts on page 19.

(Continued on following page)

CHV-TSTATEX Troubleshooting (Continued)

TROUBLE	POSSIBLE CAUSE(S)	CORRECTIVE ACTION
System cycles too quickly.	Anticipator setting is too low.	Reprogram anticipator setting (refer to "Setup Mode Parameters/Functions" which starts on page 19).
Poor battery life.	Ensure that the power source switch selection position is proper for the expected conditions.	Using the 24VAC position prevents power steal operation and will cause a device to run on battery alone if no 24V input is available.
		Using the STEAL position will prevent the 24V input from being used even if it is available.
		Cool-only applications with nothing connected to R or W cannot power-steal.
		Ensure heat system is available if using power steal or follow the cool-only notes in that section.
	Check for communication problems using standard RF troubleshooting.	Fringe communication and excessive gateway reconnect attempts cause extended runtime which consumes battery power more quickly.
	Unit is using remote sensors.	Avoid using remote sensors when running on battery alone. Setup system so that power-steal is available.
	A long backlight time is being used.	Avoid long backlight runtimes if the user interface is operated frequently.
Room has high temperature variance.	Anticipator setting is too high.	Reprogram anticipator setting (refer to "Setup Mode Parameters/Functions" which starts on page 19).
Wide temperature variance in single setpoint <i>Auto</i> mode.	Auto dead band setting is too high.	Reprogram auto dead band (db) setting (refer to "Setup Mode Parameters/Functions" which starts on page 19).
Heating/Cooling not operating in single setpoint <i>Auto</i> mode.	20 minute system toggling lockout.	Reprogram auto dead band (db) and anticipator settings for smoother operation (refer to "Setup Mode Parameters/Functions" which starts on page 19).
Can not enter <i>Auto</i> mode.	<i>Auto</i> mode is disabled in setup.	Reprogram <i>Auto</i> mode setting (AU) to "S" (for single setpoint operation) or "d" (for dual setpoint operation) (refer to "Setup Mode Parameters/Functions" which starts on page 19).

(Continued on following page)

CHV-TSTATEX Troubleshooting (Continued)

TROUBLE	POSSIBLE CAUSE(S)	CORRECTIVE ACTION
Wrong temperature is displayed.	Wrong temperature scale.	Select F or C as necessary.
	A Temperature Offset has been applied.	Reset Temperature Offset (refer to "Setup Mode Parameters/Functions" which starts on page 19).
	Bad location.	Ensure the thermostat is located away from direct sunlight, drafts, doorways, skylights and windows or exterior walls.
	Incorrect sensor source.	Ensure that the settings on "ir" screen recall the temperature from the correct source. Refer to "Setup Mode Parameters/Functions" which starts on page 19 for additional information.
Heat or cool call occurs but device does not indicate a heat or cool call.	Steal power function may be causing problems with HVAC system.	Change Power DIP Switch to 24VAC and ensure you have two AA batteries installed.
	Improper wiring connections.	Recheck wiring connections.

Reference Documents

The latest version of all Documents mentioned within the guide can be obtained from the Crestron Web site (<http://www.crestron.com/manuals>).

List of Related Reference Documents

DOCUMENT TITLE
2-Series Control Systems Reference Guide
CEN-RFGW-EX infiNET EX Wireless Gateway
MC3 3-Series Control System

Further Inquiries

If you cannot locate specific information or have questions after reviewing this guide, please take advantage of Crestron's award winning customer service team by calling Crestron at 1-888-CRESTRON [1-888-273-7876]. For assistance in your region, please refer to the Crestron Web site (www.crestron.com/offices) for a listing of Crestron worldwide offices.

You can also log onto the online help section of the Crestron Web site (www.crestron.com/onlinehelp) to ask questions about Crestron products. First-time users will need to establish a user account to fully benefit from all available features.

Future Updates

As Crestron improves functions, adds new features and extends the capabilities of the CHV-TSTATEX-FCU, additional information may be made available as manual updates. These updates are solely electronic and serve as intermediary supplements prior to the release of a complete technical Documentation revision.

Check the Crestron Web site periodically for manual update availability and its relevance. Updates are identified as an “Addendum” in the Download column.

Glossary

Anticipators

Used to anticipate the drop or rise in temperature and energize the appropriate system before reaching the set point. Anticipators affect how tightly the setpoint temperature is maintained.

Auto Dead Band

Sets the minimum separation in auto mode between heat and cool setpoints (with dual setpoints) or maximum drift before system latches alternate mode (with single setpoint).

Blower (Fan)

An air-handling device for moving air in a distribution system.

Call

A call is the action taken by the thermostat when it sends a signal to turn on the heating or cooling system.

Extended Cool

Extends the cool setpoint range to the full auto range of 38 to 99°F.

Humidity

The total amount of moisture in air. Relative humidity (RH) is the amount of moisture in air, relative to its total capability based upon its temperature (dew point). Moisture will condense on surfaces that are below this dew point.

HVAC

Heating, ventilation and air conditioning.

Setpoint

The user selectable temperature you want the system to maintain.

Time Delay (Timer Guards)

Refers to a safety device or circuit that will not allow restart for three minutes.

Return and Warranty Policies

Merchandise Returns / Repair Service

1. No merchandise may be returned for credit, exchange or service without prior authorization from Crestron. To obtain warranty service for Crestron products, contact an authorized Crestron dealer. Only authorized Crestron dealers may contact the factory and request an RMA (Return Merchandise Authorization) number. Enclose a note specifying the nature of the problem, name and phone number of contact person, RMA number and return address.
2. Products may be returned for credit, exchange or service with a Crestron Return Merchandise Authorization (RMA) number. Authorized returns must be shipped freight prepaid to Crestron, 6 Volvo Drive, Rockleigh, N.J. or its authorized subsidiaries, with RMA number clearly marked on the outside of all cartons. Shipments arriving freight collect or without an RMA number shall be subject to refusal. Crestron reserves the right in its sole and absolute discretion to charge a 15% restocking fee plus shipping costs on any products returned with an RMA.
3. Return freight charges following repair of items under warranty shall be paid by Crestron, shipping by standard ground carrier. In the event repairs are found to be non-warranty, return freight costs shall be paid by the purchaser.

Crestron Limited Warranty

Crestron Electronics, Inc. warrants its products to be free from manufacturing defects in materials and workmanship under normal use for a period of three (3) years from the date of purchase from Crestron, with the following exceptions: disk drives and any other moving or rotating mechanical parts, pan/tilt heads and power supplies are covered for a period of one (1) year; touch screen display and overlay components are covered for 90 days; batteries and incandescent lamps are not covered.

This warranty extends to products purchased directly from Crestron or an authorized Crestron dealer. Purchasers should inquire of the dealer regarding the nature and extent of the dealer's warranty, if any.

Crestron shall not be liable to honor the terms of this warranty if the product has been used in any application other than that for which it was intended or if it has been subjected to misuse, accidental damage, modification or improper installation procedures. Furthermore, this warranty does not cover any product that has had the serial number altered, defaced or removed.

This warranty shall be the sole and exclusive remedy to the original purchaser. In no event shall Crestron be liable for incidental or consequential damages of any kind (property or economic damages inclusive) arising from the sale or use of this equipment. Crestron is not liable for any claim made by a third party or made by the purchaser for a third party.

Crestron shall, at its option, repair or replace any product found defective, without charge for parts or labor. Repaired or replaced equipment and parts supplied under this warranty shall be covered only by the unexpired portion of the warranty.

Except as expressly set forth in this warranty, Crestron makes no other warranties, expressed or implied, nor authorizes any other party to offer any warranty, including any implied warranties of merchantability or fitness for a particular purpose. Any implied warranties that may be imposed by law are limited to the terms of this limited warranty. This warranty statement supersedes all previous warranties.

This page is intentionally left blank.



Crestron Electronics, Inc.
15 Volvo Drive Rockleigh, NJ 07647
Tel: 888.CRESTRON
Fax: 201.767.7576
www.crestron.com

**Operations & Installation Guide – DOC. 7206B
(2031609)**

01.12

Specifications subject to
change without notice.