

Crestron GLPP-SWCN Series
Crestron Green Light® Power Pack, Switcher with Cresnet®
Installation Guide



Further Inquiries

If you cannot locate specific information or have questions after reviewing this guide, please take advantage of Crestron's award winning customer service team by calling Crestron® at 1-888-CRESTRON [1-888-273-7876]. For assistance in your region, please refer to the Crestron Web site (www.crestron.com) for a listing of Crestron worldwide offices.

You can also log onto the online help section of the Crestron Web site (www.crestron.com/onlinehelp) to ask questions about Crestron products. First-time users will need to establish a user account to fully benefit from all available features.

Future Updates

As Crestron improves functions, adds new features and extends the capabilities of the GLPP-SWCN Series units, additional information may be made available as manual updates. These updates are solely electronic and serve as intermediary supplements prior to the release of a complete technical documentation revision.

Check the Crestron Web site periodically for manual update availability and its relevance. Updates are identified as an "Addendum" in the Download column.

WARNING: To avoid fire, shock, or death; turn off power at circuit breaker or fuse and test that power is off before wiring!

NOTES: Observe the following points.

- To be installed and/or used in accordance with appropriate electrical codes and regulations.
- This product should be installed by a qualified electrician.
- Sensors must be mounted on a vibration free surface.

PREPARING AND CONNECTING WIRES

Strip the ends of the wires approximately 1/4 in (6 mm). Use care to avoid nicking the conductors. Twist together the ends of the wires that share a connection. Apply solder only to the ends of the twisted wires. Avoid tinning too far up the wires or the end becomes brittle.

Crestron Electronics, Inc.

15 Volvo Drive Rockleigh, NJ 07647
Tel: 888.CRESTRON
Fax: 201.767.7576
www.crestron.com

Installation Guide - DOC. 7207A

(2032693)
11.11
Specifications subject to change without notice.

This product is Listed to applicable

UL Standards and requirements by Underwriters Laboratories Inc.



DESCRIPTION

The Crestron Green Light® Power Pack is a standalone room controller designed to communicate with photocells, occupancy sensors, and control stations to automatically control lighting in any room. The entire Green Light Power Pack family provides cost-effective and powerful lighting control for classrooms, small offices, and open-plan offices. Ideal for new construction as well as retrofitting existing buildings, Green Light Power Packs are designed to install and commission quickly and easily. Additionally, the Green Light Power Pack can be connected to a central control system, enabling it to become an integral part of the building energy management system.

Easy Installation

Designed to mount directly over a pair of adjacent 4" square electrical junction boxes, the Green Light Power Pack is easy to prepare for-and install. High- and low-voltage connections are made using the labeled color-coded flying-lead wires. Once installed, each unit is instantly operational, providing out-of-the-box default settings adequate for many applications. Further commissioning tweaks are a snap using the IR remote control (GLPPA-REMOTE-PROG, not supplied) for setup.

Models

MODEL	DESCRIPTION
GLPP-SWCN	Crestron Green Light Power Pack, 1-Channel Switch with Cresnet®
GLPP-1SWCN2CN	Crestron Green Light Power Pack, 2-Channel Switch with Cresnet®
GLPP-1SWCN3CN	Crestron Green Light Power Pack, 3-Channel Switch with Cresnet®

Specifications

Specifications for the GLPP-SWCN Series is listed in the following table.

GLPP-SWCN Series Specifications

SPECIFICATION	DETAILS
Switched Channels	1, 2 or 3 switched loads (depending on model)
Per Unit	16 Amps Total @ 100-277 VAC, 50/60 Hz
Switch Load Types	Incandescent, Magnetic Low Voltage, Electronic Low Voltage, Neon, Cold Cathode, Fluorescent Ballast, HID
Relay Lifetime	1,000,000 cycles
Power Requirements	100-277 VAC, 50/60 Hz
Main Power	2.5 W @ 24 Volts DC (sufficient for powering both the occupancy sensor and photocell)
Available Sensor Power	
Environmental	
Temperature	32° F to 104° F (0° C to 40° C)
Humidity	10 to 90% RH (non-condensing)
Dimensions	
Height	4 1/4 in (108 mm)
Width	8 11/16 in (221 mm)
Depth	2 in (51 mm)
Weight	2 lb (907 g)
Enclosure	20-gauge galvanized steel enclosure, designed for mounting to two adjacent 4" square electrical junction boxes; 3-channel versions require a box depth of 2 1/8 in (54 mm)
2-Series Control System Update File	Version 4.001.1012 or later*
3-Series Control System Update File	Version 1.2.0 or later*

* The latest software versions can be obtained from the Crestron Web site. Refer to the NOTE following these footnotes.

NOTE: Crestron software and any files on the Web site are for authorized Crestron dealers and Crestron Authorized Independent Programmers (CAIP) only. New users may be required to register to obtain access to certain areas of the site (including the FTP site).

Important Notes

Read before wiring and installation.

CAUTION: To be installed with 14 AWG (2.5 mm²) and 18 AWG (0.75 mm²) wire that complies with local electrical codes.

Physical Description

This section provides information on the connections, controls and indicators available on the GLPP-SWCN Series.

GLPP-SWCN Series Overall Dimensions

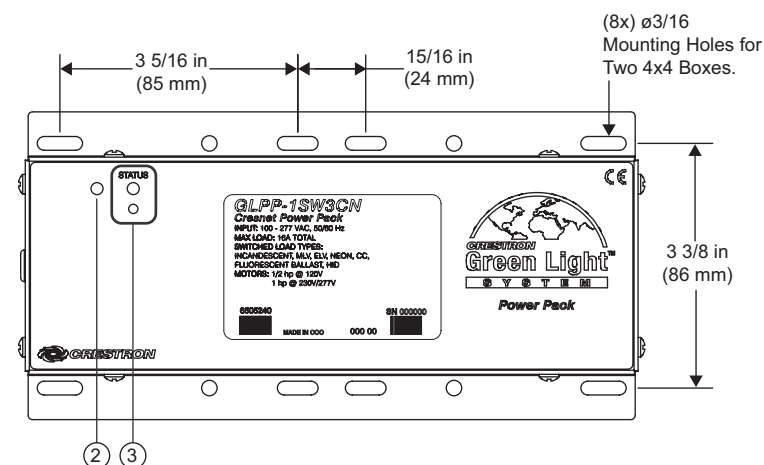
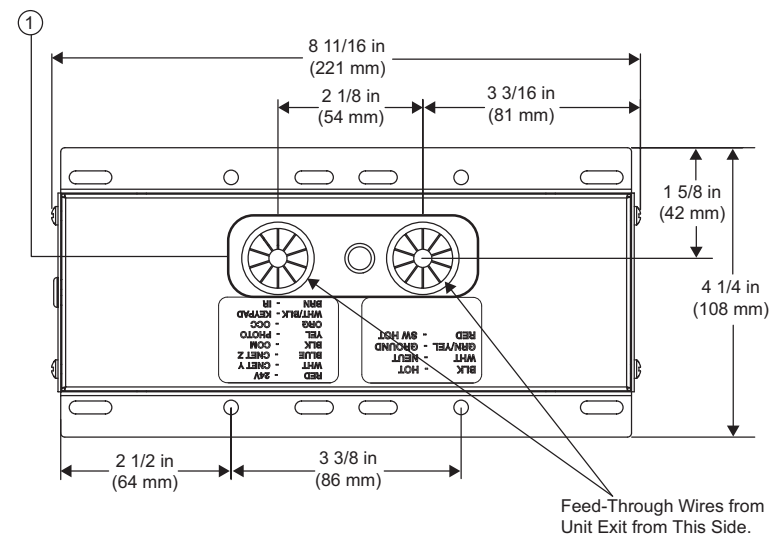

Connectors, Controls & Indicators

#	CONNECTORS, CONTROLS & INDICATORS	DESCRIPTION
1		Connections (Class 1 and Class 2): Line In (100-277 VAC): (1) 14 AWG Class 1 flying lead, black Neutral: (1) 14 AWG Class 1 flying lead, white Switched Hot: (1, 2 or 3) 14 AWG Class 1 flying lead(s), red, labeled with channel number Ground: (1) 14 AWG Class 1 flying lead, green with yellow stripe Common: (1) 18 AWG Class 2 flying lead, black; common for sensors, IR and Cresnet Sensor Power (24VDC): (1) 18 AWG Class 2 flying lead, red Occupancy Sensor Signal: (1) 18 AWG Class 2 flying lead, orange Photocell Signal: (1) 18 AWG Class 2 flying lead, yellow IR: (1) 18 AWG Class 2 flying lead, brown, for use with (optional) external IR receiver Keypads: (2) 18 AWG Class 2 flying leads, white with black stripe; supports up to two (2) GLPPA-KP Power Pack Keypads Cresnet Data Z: (1) 18 AWG Class 2 flying lead, blue Cresnet Data Y: (1) 18 AWG Class 2 flying lead, white
2		IR window for use with commissioning remote.
3	SETUP	LED and recessed miniature push button for enabling setup mode.

WIRING

WARNING: Turn off power to the GLPP-SWCN Series unit before wiring. Wiring with power on can result in serious personal injury and damage to the device.

Typical Wiring Diagram

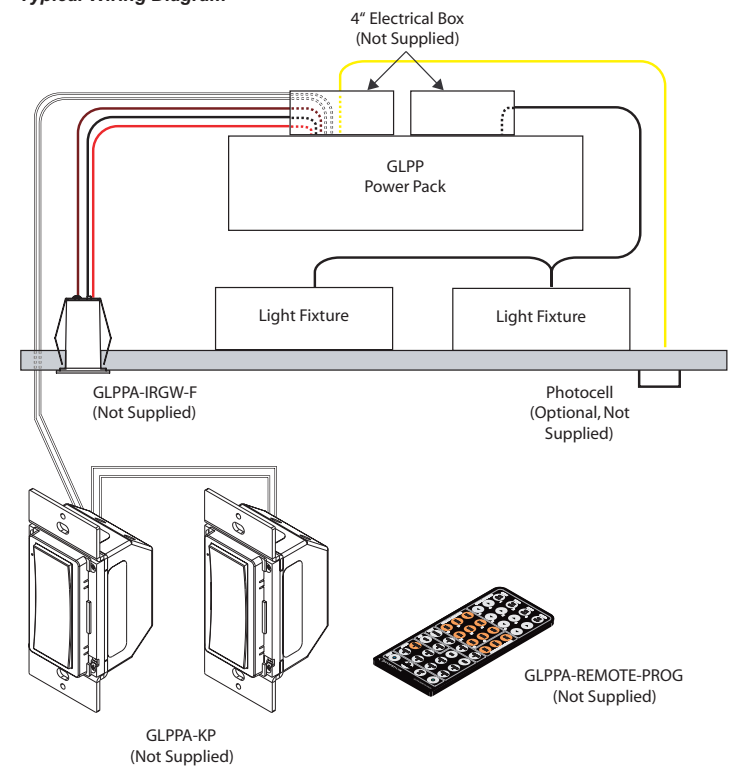

COMMISSIONING

Before the GLPP-SWCN Series Power Pack can be used it must be commissioned. During commissioning the scene selections will be configured along with the daylighting levels. The actions of the occupancy sensors will also be configured.

Scene Setup

Use the GLPPA-REMOTE-PROG (sold separately) to set up scenes 1 to 8.

1. Use **LOAD 1 ON/OFF**, **LOAD 1 ▲** and/or **LOAD 1 ▼** buttons to set the load to the desired levels. Repeat this process for the other connected loads. Alternatively, use the **MASTER ON/OFF**, **MASTER ▲** or **MASTER ▼** buttons to set the levels of all connected loads.
2. Press and hold the appropriate **SCENE 1** through **SCENE 8** button for two seconds to save the scene. The Green Light Power Pack will beep when the scene is saved.

NOTE: Only "Scene 1" will enable daylighting.

3. Repeat the steps above until all scenes have been configured.

Daylighting Levels Setup (Open Loop)

For proper operation of the daylight and minimum levels in an open loop setup the day level should be set during the day when outside light levels are high. The night level should be stored in the evening when the light levels are low.

The day and minimum levels must be modified in order to achieve optimal performance. To setup the day and minimum levels, follow the procedure outlined below.

1. Set the loads to predetermined levels that were configured using the "Scene Setup" section.
2. During the day, when the outside light levels are high, press and hold the **LOAD 1 DAY** button on the GLPPA-REMOTE-PROG to save the daytime lighting level for load 1. The Green Light Power Pack will beep once the level is saved.
3. The minimum light level can often be the same as the day light level. Set the minimum light setting by pressing and holding the **LOAD 1 MIN** button on the remote for load 1. The Green Light Power Pack will beep once the level is saved.
4. Repeat step 2 and 3 for the other attached loads.

NOTE: The day photo sensor value cannot be less than the night photo sensor value.

The night level must be modified in order to achieve optimal performance. To setup the night level, follow the procedure outlined below.

1. Set the loads to predetermined levels that were configured using the "Scene Setup" section.
2. During the evening, when the outside light levels are low, press and hold the **LOAD 1 NITE** button on the GLPPA-REMOTE-PROG to save the nighttime lighting level for load 1. The Green Light Power Pack will beep once the level is saved.
3. Repeat step 2 for the other attached loads.

NOTE: The night photo sensor value cannot be greater than the day photo sensor value.

To remove daylighting the load must be raised or lowered to the desired position then the day level and night level need to be set in succession.

Occupancy Sensor Setup

To setup the occupancy sensor and the desired recalled scene upon entry or exit of the room, follow the procedure below. The Green Light Power Pack will beep once the scene selection is saved.

1. Press and hold the desired **ENTRY** button on the GLPPA-REMOTE-PROG.
 - **ENTRY NONE:** No scene will be recalled upon entering the room.
 - **ENTRY SCENE 1:** "Scene 1" will be recalled upon entering the room.
 - **ENTRY SCENE 6:** "Scene 6" will be recalled upon entering the room.
 - **ENTRY SCENE 7:** "Scene 7" will be recalled upon entering the room.
2. Press and hold the desired **EXIT** button on the GLPPA-REMOTE-PROG.
 - **EXIT OFF:** No scene will be recalled upon exiting the room.
 - **EXIT SCENE 8:** "Scene 8" will be recalled upon exiting the room.

Return and Warranty Policies

Merchandise Returns / Repair Service

1. No merchandise may be returned for credit, exchange or service without prior authorization from CRESTRON. To obtain warranty service for CRESTRON products, contact an authorized CRESTRON dealer. Only authorized CRESTRON dealers may contact the factory and request an RMA (Return Merchandise Authorization) number. Enclose a note specifying the nature of the problem, name and phone number of contact person, RMA number and return address.
2. Products may be returned for credit, exchange or service with a CRESTRON Return Merchandise Authorization (RMA) number. Authorized returns must be shipped freight prepaid to CRESTRON, 6 Volvo Drive, Rockleigh, N.J. or its authorized subsidiaries, with RMA number clearly marked on the outside of all cartons. Shipments arriving freight collect or without an RMA number shall be subject to refusal. CRESTRON reserves the right in its sole and absolute discretion to charge a 15% restocking fee plus shipping costs on any products returned with an RMA.
3. Return freight charges following repair of items under warranty shall be paid by CRESTRON, shipping by standard ground carrier. In the event repairs are found to be non-warranty, return freight costs shall be paid by the purchaser.

CRESTRON Limited Warranty

CRESTRON ELECTRONICS, Inc. warrants its products to be free from manufacturing defects in materials and workmanship under normal use for a period of three (3) years from the date of purchase from CRESTRON, with the following exceptions: disk drives and any other moving or rotating mechanical parts, pan/tilt heads and power supplies are covered for a period of one (1) year; touch screen display and overlay components are covered for 90 days; batteries and incandescent lamps are not covered.

This warranty extends to products purchased directly from CRESTRON or an authorized CRESTRON dealer. Purchasers should inquire of the dealer regarding the nature and extent of the dealer's warranty, if any.

CRESTRON shall not be liable to honor the terms of this warranty if the product has been used in any application other than that for which it was intended or if it has been subjected to misuse, accidental damage, modification or improper installation procedures. Furthermore, this warranty does not cover any product that has had the serial number altered, defaced or removed.

This warranty shall be the sole and exclusive remedy to the original purchaser. In no event shall CRESTRON be liable for incidental or consequential damages of any kind (property or economic damages inclusive) arising from the sale or use of this equipment. CRESTRON is not liable for any claim made by a third party or made by the purchaser for a third party.

CRESTRON shall, at its option, repair or replace any product found defective, without charge for parts or labor. Repaired or replaced equipment and parts supplied under this warranty shall be covered only by the unexpired portion of the warranty.

Except as expressly set forth in this warranty, CRESTRON makes no other warranties, expressed or implied, nor authorizes any other party to offer any warranty, including any implied warranties of merchantability or fitness for a particular purpose. Any implied warranties that may be imposed by law are limited to the terms of this limited warranty. This warranty statement supersedes all previous warranties.

Crestron, the Crestron logo, Cresnet and Crestron Green Light are trademarks or registered trademarks of Crestron Electronics, Inc. in the United States and other countries. UL and the UL logo, are either trademarks or registered trademarks of Underwriters Laboratories, Inc. in the United States and/or other countries. Other trademarks, registered trademarks and trade names may be used in this document to refer to either the entities claiming the marks and the names or their products. Crestron disclaims any proprietary interest in the marks and names of others.
©2011 Crestron Electronics, Inc.