

## Functional Summary

The Crestron® 75 Watt Power Supply Terminal Block and Module (CLT-PWS75 and CLX-PWS75, respectively) are considered a single entity and must be used together. They ship separately to permit termination of the field wiring to the CLT-PWS75 prior to installation of the CLX-PWS75, as described in this guide. The CLX-PWS75 is a power supply module that provides up to 75 Watts of Cresnet® power to Crestron equipment. The terminal block and module can be mounted in any Crestron Automation Enclosure (CAEN-Series Enclosures, refer to the NOTE in the next column). The terminal block is designed to terminate the circuit feed (LINE and NEUTRAL) and distribute the power to a connector on a supplied cable assembly (LOAD) that connects to the power supply module. The power supply module operates with an input of 100 to 250 VAC, 2.3A (maximum). The power supply module has a fuse that protects the 24 VDC output. If the network power lines are shorted, the fuse is blown. As a result, the **NET POWER LED** extinguishes.

### Regulatory Compliance

This product is Listed to applicable UL Standards and requirements by Underwriters Laboratories Inc.



## Installation

The terminal block and module must be mounted into a Crestron Automation Enclosure by a licensed electrician, in accordance with all national and local codes.

**CAUTION:** This equipment is for indoor use only and needs to be air-cooled. Mount in a well-ventilated area. The ambient temperature must be 32°F to 104°F (0°C to 40°C). The relative humidity must be 0% to 90% (non-condensing).

Terminal blocks are installed along the left side of single-wide enclosures and along the outside edges (left and right sides) of double-wide enclosures. Modules are installed along the right side of single-wide enclosures and side-by-side in the center of double-wide enclosures. When installing modules and terminal blocks in a double-wide enclosure, be sure to invert units on the right side so that they can be properly wired. Refer to the illustrations shown in the next column when considering the location of terminal blocks and modules within an enclosure.

**Crestron Electronics, Inc.**  
 15 Volvo Drive Rockleigh, NJ 07647  
 Tel: 888.CRESTRON  
 Fax: 201.767.7576  
 www.crestron.com

**NOTE:** Modules and terminal blocks must be installed into the lowest available spaces and continue toward the top of the enclosure.

### Terminal Block & Module Locations (Single-wide Enclosure)

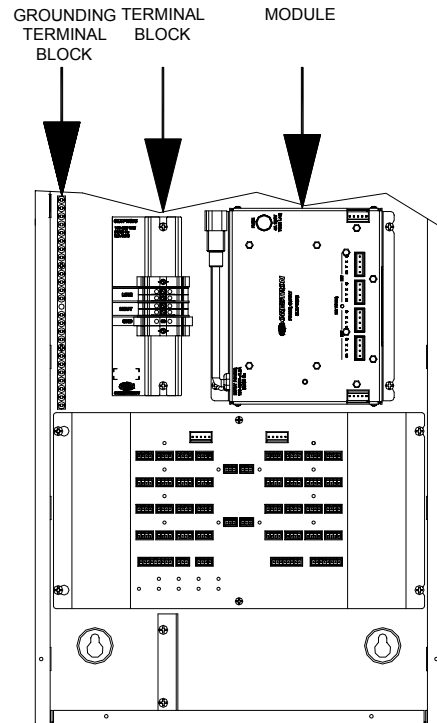

### Terminal Block & Module Locations (Double-wide Enclosure)

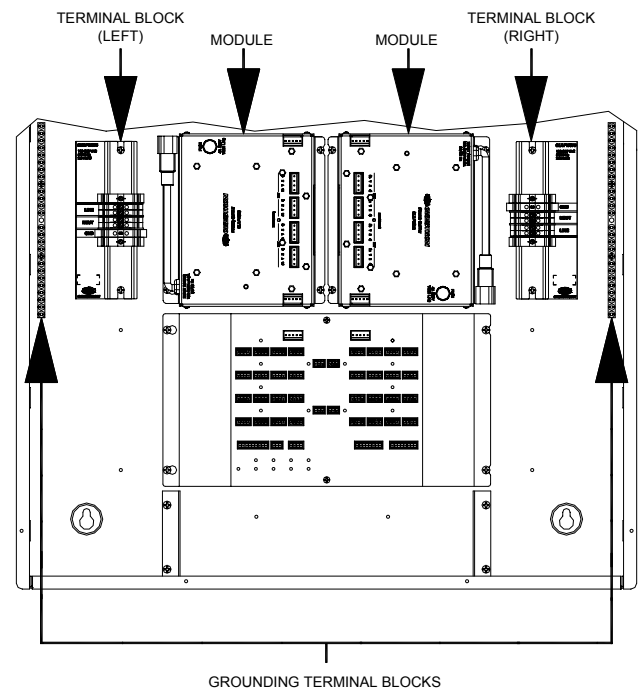

## Terminal Block Installation and Field Wiring

**CAUTION: RISK OF ELECTRIC SHOCK—MORE THAN ONE DISCONNECT SWITCH MAY BE REQUIRED TO DE-ENERGIZE THE EQUIPMENT BEFORE SERVICING.**

**NOTE:** Both left-side and right-side adhesive wiring labels are provided. The left-side labels are used in both single and double-wide enclosures. The right-side labels are only used in double-wide enclosures.

1. Remove the backing from the left or right adhesive wiring label.
2. Apply the adhesive label by aligning the holes in the label with the holes on the Crestron Automation Enclosure where the terminal block is to be mounted. The wiring label lies beneath the terminal block as shown in the two wiring diagrams on this page.
3. Use the two supplied self-tapping pan Phillips screws (8B x 1/4 length) to secure the terminal block to the Crestron Automation Enclosure.

**NOTE:** Use copper conductors only – rated 75°C.

4. With the circuit breaker turned off, connect the circuit feeds (LINE, NEUTRAL, and GROUND) to the terminal block per the markings provided on the wiring label (as shown in the following diagram). Terminal blocks accept one 14 - 10 AWG wire. Wires should be stripped to 1/2 inch. Tighten terminal blocks to 9 in-lbs.

**NOTE:** LINE and NEUTRAL lines can be jumped to other terminal blocks in the enclosure.

5. Grounding terminal blocks are available in the cabinet for termination of ground wires. Tighten to 35 in-lbs. (14 – 10 AWG).
6. Connect each wire from the connector assembly to the terminal block. Each wire is the same color as the terminal to which it should be connected. Wires are pre-stripped to 1/2 inch. Tighten to 9 in-lbs.
7. Test the circuit for electrical faults by turning on the circuit breaker and checking that the breaker does not trip and that power is supplied to the connector of the cable assembly.

*Wiring Diagram of the Terminal Block to the Feed and Load(s)(Single-wide and Left Side Double-wide Enclosures)*

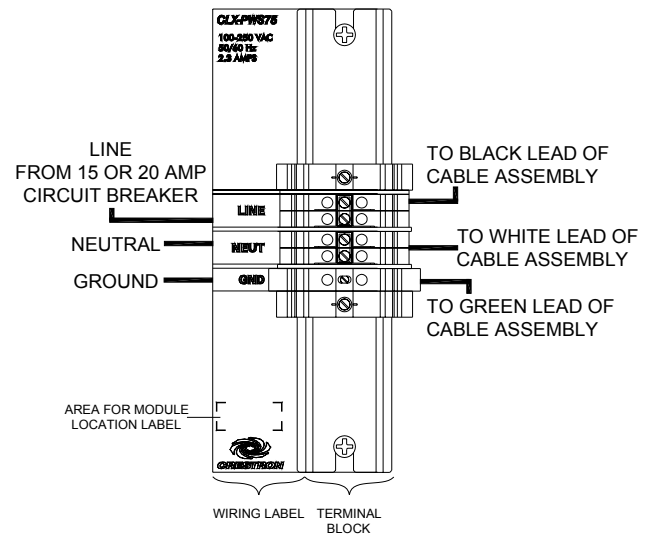

*Wiring Diagram of the Terminal Block to the Feed and Load(s)(Right Side Double-wide Enclosures)*

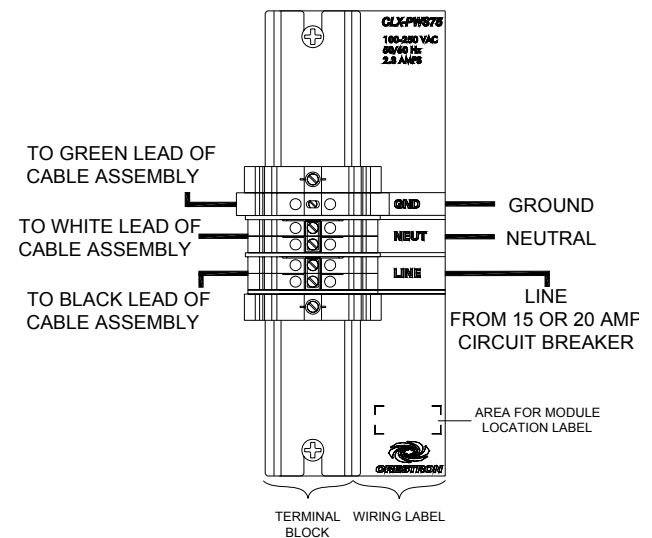

## Module Installation

**CAUTION:** The module contains electrostatic sensitive devices (ESDs); unit must be handled from metal chassis – do not touch PC board or components.

**NOTE:** Modules are to be installed after enclosure has been completely wired. Refer to the terminal block installation procedure on the top of the page for details.

1. Use the four supplied self-tapping screws (8B x 1/4 length) to secure the module to the enclosure.
2. If the module is being installed below another module within the enclosure, attach the supplied module interconnect cable between the two

modules. The following illustration depicts the area within a double-wide enclosure where the corners of four modules meet.

**NOTE:** One wire on the module interconnect cable may be a different color from the rest. The color has no bearing on its orientation during installation.

### Use Module Interconnect Cable to Wire Module to Module

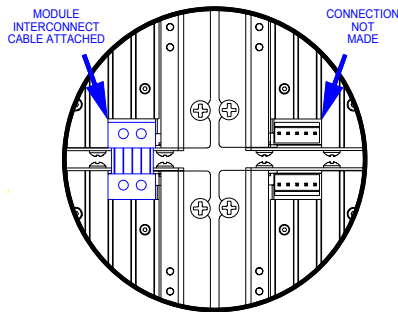

3. Connect the module's female connector to the male connector that is wired to the terminal block.
4. Turn on the circuit breaker and verify that the breaker does not trip.

**NOTE:** If the fuse is to be replaced, replace only with the same fuse type and rating. A time lag is required.

## Network Device Wiring

**CAUTION:** In order to ensure optimum performance over the full range of your installation topology, Crestron Certified Wire and only Crestron Certified Wire may be used. Failure to do so may incur additional charges if support is required to identify performance deficiencies because of using improper wire.

**CAUTION:** Use only Crestron power supplies for Crestron equipment. Failure to do so could cause equipment damage or void the Crestron warranty.

**CAUTION:** Provide sufficient power to the system. Insufficient power can lead to unpredictable results or damage to the equipment. Please use the Crestron Power Calculator ([www.crestron.com/calculators](http://www.crestron.com/calculators)) to help calculate how much power is needed for the system.

**CAUTION:** Possible equipment damage if miswired.

**NOTE:** When installing network wiring, refer to the latest revision of the wiring diagram(s) appropriate to your specific system configuration, available from the Crestron Web site.

**NOTE:** Do not power up system until all wiring is verified. Care should be taken to ensure data (Y, Z) and ground (G) connections are not crossed when connecting Cresnet devices.

When calculating the length of wire for a particular Cresnet run, the wire gauge and the Cresnet power usage of each network unit to be connected must be taken into consideration. Use Crestron Certified Wire only. If Cresnet units are to be daisy-chained on the run, the Cresnet power usage of each network unit to be daisy-chained must be added together to determine the Cresnet power usage of the entire chain. If the unit is home-run from a Crestron system power supply network port, the Cresnet power usage of that unit is the Cresnet power usage of the entire run. The wire gauge and the Cresnet power usage of the run should be used in the following equation to calculate the cable length value on the equation's left side.

### Cable Length Equation

$$L < \frac{40,000}{R \times P}$$

Where: R = 6 Ohms (Crestron Certified Wire: 18 AWG (0.75 MM<sup>2</sup>))  
 or 1.6 Ohms (Cresnet HP: 12 AWG (4MM<sup>2</sup>))  
 L = Length of run (or chain) in feet.  
 P = Cresnet power usage of entire run (or chain).

Make sure the cable length value is less than the value calculated on the right side of the equation. For example, a Cresnet run using 18 AWG Crestron Certified Wire and drawing 20 watts should not have a length of run more than 333 feet. If Cresnet HP is used for the same run, its length could extend to 1250 feet (381 meters).

**NOTE:** All Crestron certified Cresnet wiring must consist of two twisted pairs. One twisted pair is the +24V conductor and the GND conductor and the other twisted pair is the Y conductor and the Z conductor.

**NOTE:** When daisy-chaining Cresnet units, strip the ends of the wires carefully to avoid nicking the conductors. Twist together the ends of the wires that share a pin on the network connector and tin the twisted connection. Apply solder only to the ends of the twisted wires. Avoid tinning too far up the wires or the end becomes brittle. Insert the tinned connection into the Cresnet connector and tighten the retaining screw. Repeat the procedure for the other three conductors.

**NOTE:** For larger networks (i.e., greater than 28 network devices), it may become necessary to add a Cresnet Hub/Repeater (CNXHUB) to maintain signal quality throughout the network. Also, for networks with lengthy cable runs it may be necessary to add a Hub/Repeater after only 20 devices.

## Hardware Hookup

The venting holes on the sides and top of the module should not be obstructed under any circumstances. If the module is hot to the touch, consider using forced air ventilation or implementing additional supplies to distribute the load.

### Hookup Preparation

Prior to making hardware connections, it is assumed that all wiring is run. This includes the connection of network connectors. However, the network connectors should not yet be plugged into the network devices. Use an ohmmeter to verify that none of the four network conductors are shorted or crossed. Furthermore, each network device must have a unique Net ID. If necessary, refer to the product documentation for the appropriate Net ID assignment procedure of each device.

### Hookup Methods

The hookup diagram on the next page illustrates the home run and daisy chain methods of connecting the module. It also illustrates multiple modules within a single Cresnet system (each module must be installed in its own CAEN enclosure). Only use the methods shown; do not connect multiple power supplies together in parallel. If only one power supply is necessary, use either method connected to a control system.

**NOTE:** Always disconnect AC power to the module supplying power to a Cresnet system before connecting a network device to that system or installing a card in the control system.

**NOTE:** Never connect multiple modules in parallel.

### Hookup Procedure

1. Connect the control system and each network device to a network connector on the module.
2. Connect AC power to the module.
3. If a PC (running SIMPL Windows) is available, connect the PC to the Cresnet system via the computer port on the control system.
4. Establish communications with the control system as described in the latest version of the Crestron 2-Series Control Systems Reference Guide (Doc. 6256) which is available from the Crestron Web site ([www.crestron.com/manuals](http://www.crestron.com/manuals)).

5. Using Crestron Toolbox, display the network device tree (**Tools | Network Device Tree**) to show all network devices connected to the control system. If a device is properly connected, it will be listed in the network device tree.

## Problem Solving

### Troubleshooting

The table after this paragraph provides corrective action for possible trouble situations. If further assistance is required, please contact a Crestron customer service representative.

#### CLX-PWS75 Troubleshooting

TROUBLE	POSSIBLE CAUSE(S)	CORRECTIVE ACTION
<b>NET POWER</b> LED is not illuminated.	Module is not receiving power.	Verify that module is properly connected to terminal block and terminal block is properly connected to circuit breaker.
	Fuse is blown.	Refer to "Hookup Procedure" and test the network for shorts. Replace fuse.
<b>NET POWER</b> LED flashes.	Cresnet power requirements for supply is exceeded.	Confirm load on supply. Add more power supplies to the network if necessary.
Network devices are not receiving power.	Varied	From SIMPL Windows, select <b>Tools   Network Analyzer</b> and perform voltage-level tests on the troubled network device. Refer to the SIMPL Windows help file for details.

*CLX-PWS75 Hardware Hookup*

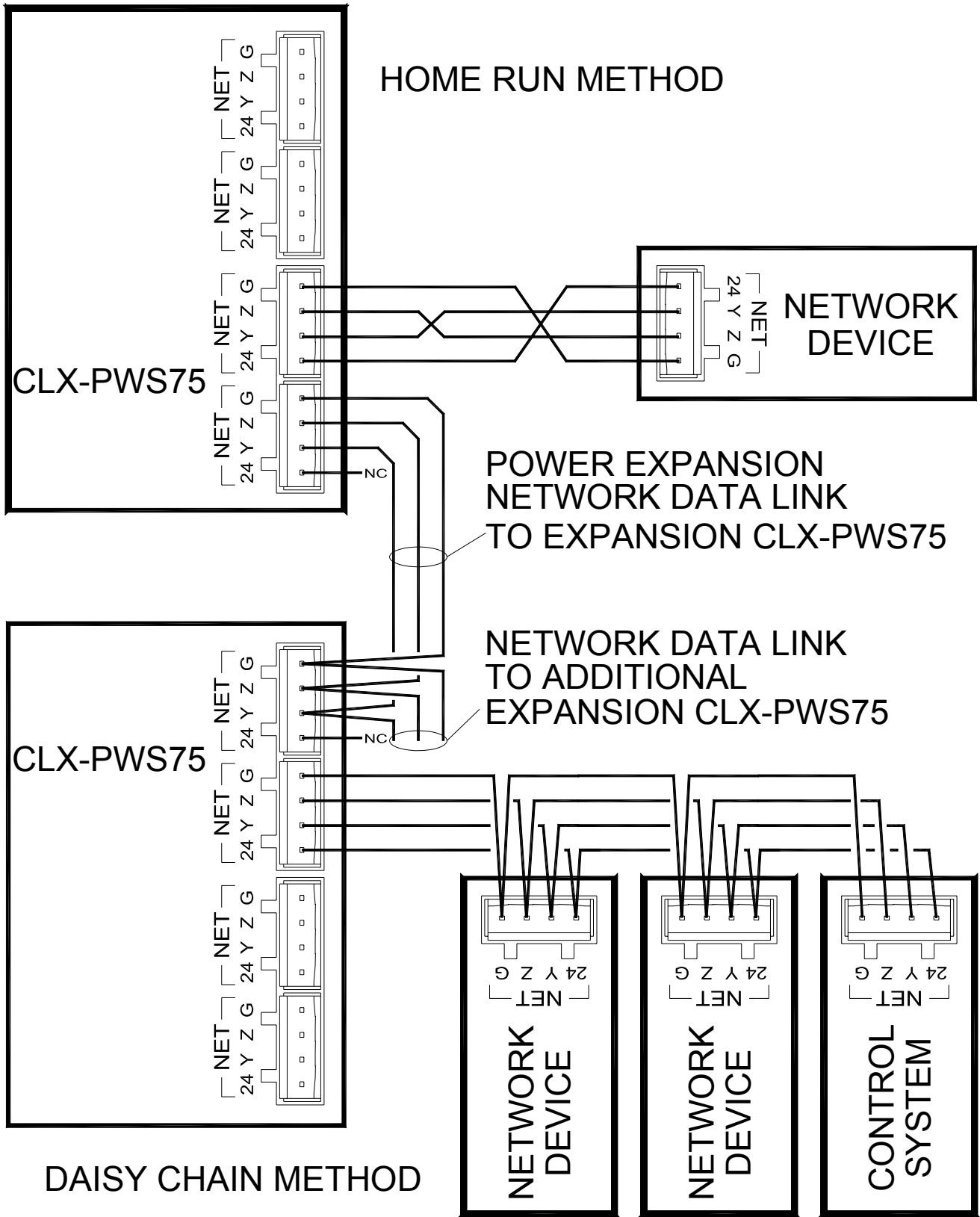

## Reference Documents

The latest version of all documents mentioned within the guide can be obtained from the Crestron Web site ([www.crestron.com/manuals](http://www.crestron.com/manuals)).

### List of Related Reference Documents

DOCUMENT TITLE
2-Series Control Systems Reference Guide

## Further Inquiries

If you cannot locate specific information or have questions after reviewing this guide, please take advantage of Crestron's award winning customer service team by calling Crestron at 1-888-CRESTRON [1-888-273-7876]. For assistance in your region, please refer to the Crestron Web site ([www.crestron.com/offices](http://www.crestron.com/offices)) for a listing of Crestron worldwide offices.

You can also log onto the online help section of the Crestron Web site ([www.crestron.com/onlinehelp](http://www.crestron.com/onlinehelp)) to ask questions about Crestron products. First-time users will need to establish a user account to fully benefit from all available features.

## Future Updates

As Crestron improves functions, adds new features, and extends the capabilities of the module, additional information may be made available as manual updates. These updates are solely electronic and serve as intermediary supplements prior to the release of a complete technical documentation revision.

Check the Crestron Web site periodically for manual update availability and its relevance. Updates are identified as an "Addendum" in the Download column.

## Return and Warranty Policies

### Merchandise Returns / Repair Service

1. No merchandise may be returned for credit, exchange or service without prior authorization from CRESTRON. To obtain warranty service for CRESTRON products, contact an authorized CRESTRON dealer. Only authorized CRESTRON dealers may contact the factory and request an RMA (Return Merchandise Authorization) number. Enclose a note specifying the nature of the problem, name and phone number of contact person, RMA number and return address.
2. Products may be returned for credit, exchange or service with a CRESTRON Return Merchandise Authorization (RMA) number. Authorized returns must be shipped freight prepaid to CRESTRON, 6 Volvo Drive, Rockleigh, N.J. or its authorized subsidiaries, with RMA number clearly marked on the outside of all cartons. Shipments arriving freight collect or without an RMA number shall be subject to refusal. CRESTRON reserves the right in its sole and absolute discretion to charge a 15% restocking fee plus shipping costs on any products returned with an RMA.
3. Return freight charges following repair of items under warranty shall be paid by CRESTRON, shipping by standard ground carrier. In the event repairs are found to be non-warranty, return freight costs shall be paid by the purchaser.

### CRESTRON Limited Warranty

CRESTRON ELECTRONICS, Inc. warrants its products to be free from manufacturing defects in materials and workmanship under normal use for a period of three (3) years from the date of purchase from CRESTRON, with the following exceptions: disk drives and any other moving or rotating mechanical parts, pan/tilt heads and power supplies are covered for a period of one (1) year; touch screen display and overlay components are covered for 90 days; batteries and incandescent lamps are not covered.

This warranty extends to products purchased directly from CRESTRON or an authorized CRESTRON dealer. Purchasers should inquire of the dealer regarding the nature and extent of the dealer's warranty, if any.

CRESTRON shall not be liable to honor the terms of this warranty if the product has been used in any application other than that for which it was intended or if it has been subjected to misuse, accidental damage, modification or improper installation procedures. Furthermore, this warranty does not cover any product that has had the serial number altered, defaced or removed.

This warranty shall be the sole and exclusive remedy to the original purchaser. In no event shall CRESTRON be liable for incidental or consequential damages of any kind (property or economic damages inclusive) arising from the sale or use of this equipment. CRESTRON is not liable for any claim made by a third party or made by the purchaser for a third party.

CRESTRON shall, at its option, repair or replace any product found defective, without charge for parts or labor. Repaired or replaced equipment and parts supplied under this warranty shall be covered only by the unexpired portion of the warranty.

Except as expressly set forth in this warranty, CRESTRON makes no other warranties, expressed or implied, nor authorizes any other party to offer any warranty, including any implied warranties of merchantability or fitness for a particular purpose. Any implied warranties that may be imposed by law are limited to the terms of this limited warranty. This warranty statement supersedes all previous warranties.

Crestron, the Crestron logo and Cresnet are either trademarks or registered trademarks of Crestron Electronics, Inc. in the United States and/or other countries. UL and the UL logo are either trademarks or registered trademarks of Underwriters Laboratories, Inc. in the United States and/or other countries. Other trademarks and trade names may be used in this document to refer to either the entities claiming the marks and names or their products. Crestron disclaims any proprietary interest in the marks and names of others.  
©2011 Crestron Electronics, Inc